

# C-Lube Linear Way ML Linear Way L

# C-Lube Linear Way ML

# ML



long term maintenance free supported!

The aquamarine end plate is the symbol of maintenance free.



## Points

### ● Extremely small size realized by simple structure

For details ▶ P.I-19

Super small-size linear motion rolling guide produced by two-row four-point contact simple structure and original small sizing technology. The track rail width of LWL1, the smallest size, is only 1mm.

### ● Wide range of variations for your needs

For details ▶ P.I-25

The slide unit shape can be selected from two types, the standard type and the wide type suited for single-row track rail uses, and there are four types with different lengths of slide unit with same section. Furthermore, the track rail has the variation of standard type and tapped rail type with the screw thread implanted, allowing you to select an optimal product for the specifications of your machine and device.

### ● Ball retained type for easy operation

The slide unit of ball retained type incorporates the ball retaining band, which prevents the ball from dropping down when the slide unit is removed from the track rail.

This safety structure brings you an easy operation to the machines / equipment.

### ● Stainless steel selections for excellent corrosion resistance

For details ▶ P.I-41

Stainless steel highly corrosion-resistant is used as the basic specification, so that the products are suitable for applications where rust prevention oil is not preferred, such as in cleanroom environment. High carbon steel products suited to general purposes are also provided.

### ● Widely supports special environment uses

For details ▶ P.I-33

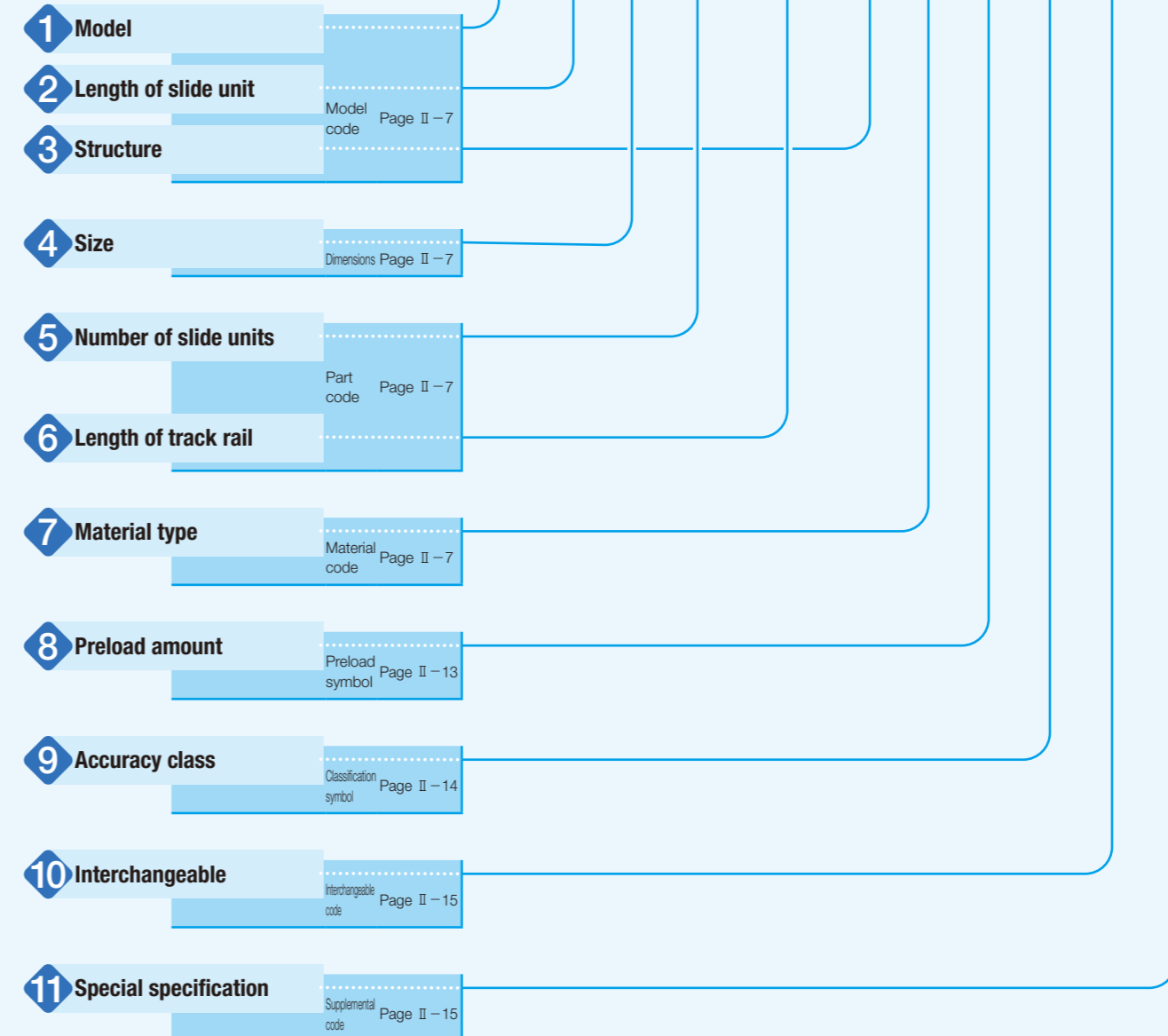
C-Lube Linear Way L for special environment uses are provided as a series. Increasingly varied special environment uses are supported, such as by high-speed / low-noise specifications by combining silicon nitride ceramics and low dust-generation specifications.

## Identification Number and Specification

### Example of an identification number

The specifications of ML(F) and LWL(F) series are indicated by the identification number. Indicate the identification number, consisting of a model code, dimensions, a part code, a material code, a preload symbol, a classification symbol, an interchangeable code, and any supplemental codes for each specification to apply.

Non-interchangeable specification	1	2	4	5	6	3	7	8	9	10	11
Assembled set	ML	C	12	C1	R200			T <sub>1</sub>	P		/U
Interchangeable specification											
Single slide unit	ML	C	12	C1				T <sub>1</sub>	P	S1	/U
Single track rail (1)	LWL		12		R200	B			P	S1	
Assembled set	ML	C	12	C1	R200			T <sub>1</sub>	P	S1	/U



Note (1) Indicate "LWL...B" or "LWLF...B" for the model code of the single track rail regardless of the series and the combination of slide unit models.  
 1N=0.102kgf=0.2248lbs.  
 1mm=0.03937inch

# Identification Number and Specification — Model · Length of Slide Unit ·

<b>1 Model</b>	C-Lube Linear Way ML (ML(F) series)	Standard type : ML Wide type : MLF	For applicable models and sizes, see Table 2.1 and Table 2.2. Indicate "LWL...B" or "LWLF...B" for the model code of the single track rail regardless of the series and the combination of slide unit models. Note (1) This model has no built-in C-Lube.
	Linear way L (1) (LWL (F) series)	Standard type : LWL Wide type : LWLF	

<b>2 Length of slide unit</b>	Short	: C	For applicable models and sizes, see Table 2.1 and Table 2.2.
	Standard	: No symbol	
	Long	: G	
	Extra long	: L	

<b>3 Structure</b>	<b>Table 1.1 Structure of ML and LWL</b>			
	Model	Types and sizes of track rails	Structure	
ML	Standard rail specification	Size: 5~25	Ball retained type : No symbol	
	Tapped rail specification	Size: 3 Size: 5, 7, 9	Ball non-retained type : No symbol Ball retained type : N	
LWL	Standard rail specification		Ball retained type : B	
	Tapped rail specification	Mounting from bottom	Size: 2, 3 Size: 5, 7, 9	Ball non-retained type : No symbol Ball retained type : N
		Mounting from lateral	Size: 1	Ball non-retained type : Y
	Solid rail specification	Size: 1	Ball non-retained type : No symbol	

**Table 1.2 Structure of MLF and LWLF**

Model	Types of track rails	Structure
MLF	Standard rail specification	Size: 6 Size: 10~42 Ball non-retained type : No symbol Ball retained type
	Tapped rail specification	Size: 6 Size: 10~18 Ball non-retained type : N Ball retained type
LWLF	Standard rail specification	Size: 4, 6 Size: 10~42 Ball non-retained type : No symbol Ball retained type : B
	Tapped rail specification	Size: 6 Size: 10~18 Ball non-retained type : N Ball retained type

For applicable models and sizes, see Table 2.1 and Table 2.2.

<b>4 Size</b>	Standard type 1, 2, 3, 5, 7, 9, 12, 15, 20, 25	For applicable models and sizes, see Table 2.1 and Table 2.2.
	Wide type 4, 6, 10, 14, 18, 24, 30, 42	

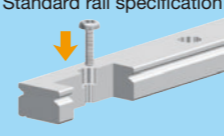
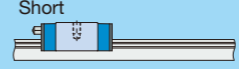





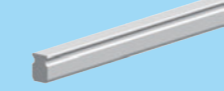





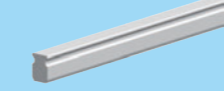
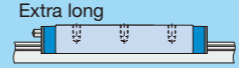

<b>5 Number of slide units</b>	: C○	For an assembled set, indicates the number of slide units assembled on a track rail. For a single slide unit, only "C1" is specified.
--------------------------------	------	---

<b>6 Length of track rail</b>	: R○	Indicate the length of track rail in mm. For standard and maximum lengths, see Table 3.1, Table 3.2, and Table 3.3.
-------------------------------	------	---

<b>7 Material type</b>	Stainless steel made	: No symbol	For applicable models and sizes, see Table 2.1 and Table 2.2.
	High carbon steel made	: CS	

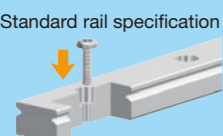
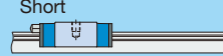




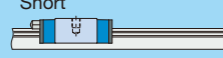

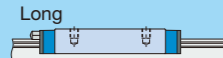
# Structure · Size · Number of Slide Unit · Length of Track Rail · Material Type —

**Table 2.1 Models and sizes of standard type ML(F) and LWL(F) series**

Types of track rails	Material type	Length of slide unit	Structure	Model	Size											
					1	2	3	5	7	9	12	15	20	25		
Standard rail specification 	Stainless steel made	Short 	Ball retained type	MLC	-	-	-	○	○	○	○	○	○	○	○	○
		LWLC...B		-	-	-	○	○	○	○	○	○	○	○		
		ML		-	-	-	○	○	○	○	○	○	○	○		
		LWL...B		-	-	-	○	○	○	○	○	○	○	○		
Tapped rail specification Mounting from bottom 	Stainless steel made	Long 	Ball retained type	MLG	-	-	-	-	○	○	○	○	○	○	○	
		LWLG...B		-	-	-	-	○	○	○	○	○	○			
		MLL		-	-	-	-	-	○	○	○	-	-			
		LWL...BCS		-	-	-	-	-	○	○	○	○	-			
Tapped rail specification Mounting from lateral 	High carbon steel made	Standard 	Ball retained type	LWL...Y	○	-	-	-	-	-	-	-	-	-	-	
		Standard 		Ball non-retained type	MLC	-	-	○	-	-	-	-	-	-	-	
		LWLC			-	-	○	-	-	-	-	-	-	-		
		Solid rail specification 		Stainless steel made	Long 	Ball retained type	MLC...N	-	-	-	○	○	○	-	-	-
LWLC...N	-		-		-		○	○	○	-	-	-				
ML	-		-		○		-	-	-	-	-	-	-			
LWL	-		○		○		-	-	-	-	-	-	-			
Tapped rail specification Mounting from bottom 	Stainless steel made	Standard 	Ball retained type	ML...N	-	-	-	○	○	○	-	-	-	-		
		LWL...N		-	-	-	○	○	○	-	-	-				
Tapped rail specification Mounting from lateral 	Stainless steel made	Long 	Ball retained type	MLG...N	-	-	-	-	○	○	-	-	-	-		
		LWLG...N		-	-	-	-	○	○	-	-	-				
Solid rail specification 	Stainless steel made	Extra long 	Ball retained type	MLL...N	-	-	-	-	-	○	-	-	-	-		
		Standard 		Ball non-retained type	LWL	○	-	-	-	-	-	-	-	-		

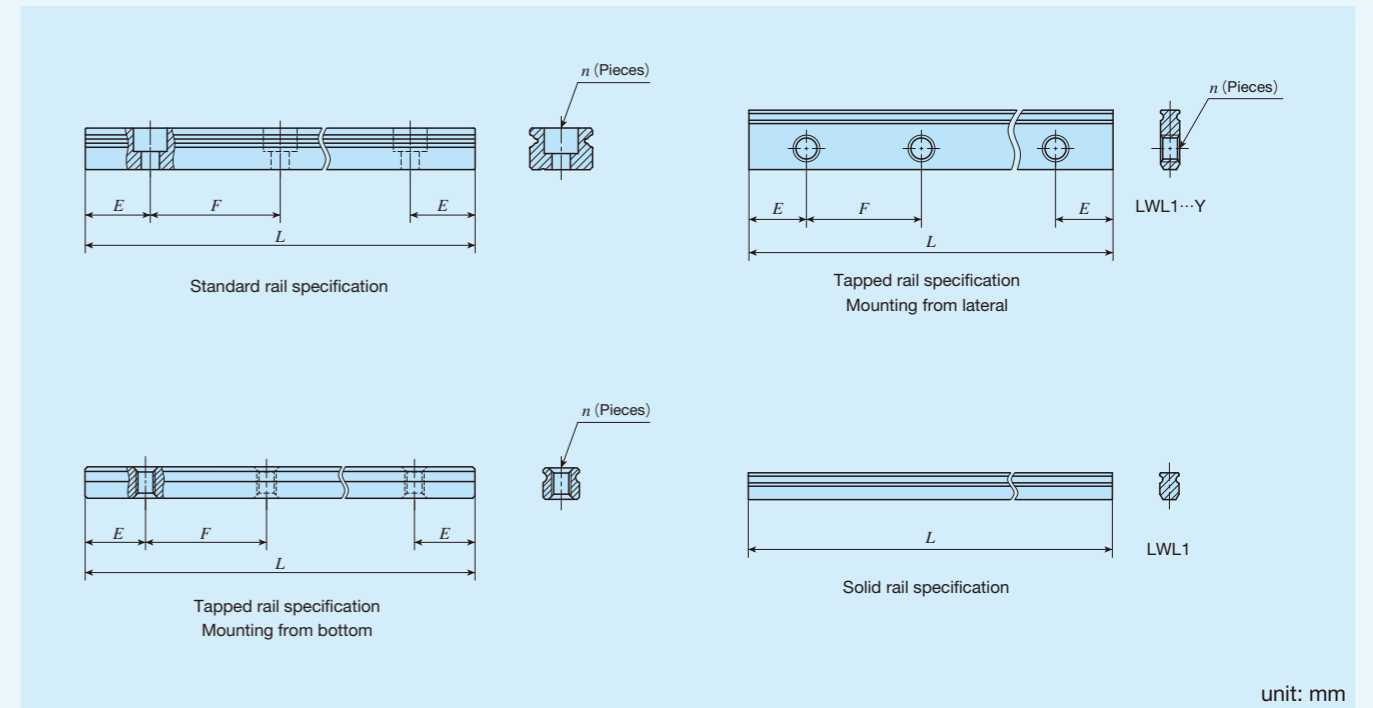
Remark: For the models indicated in  , the interchangeable specification is available.

Table 2.2 Models and sizes of wide type ML(F) and LWL(F) series

Types of track rails	Material type	Length of slide unit	Structure	Model	Size							
					4	6	10	14	18	24	30	42
Standard rail specification 	Stainless steel made	Short 	Ball retained type	MLFC	-	-	○	○	○	○	○	○
				LWLF...B	-	-	○	○	○	○	○	○
		Ball non-retained type	MLFC	-	○	-	-	-	-	-	-	-
			LWLF	-	○	-	-	-	-	-	-	-
		Standard 	Ball retained type	MLF	-	-	○	○	○	○	○	○
				LWLF...B	-	-	○	○	○	○	○	○
	Ball non-retained type	MLF	-	○	-	-	-	-	-	-	-	
		LWLF	○	○	-	-	-	-	-	-	-	
	Long 	Ball retained type	MLFG	-	-	-	○	○	○	○	○	
			LWLF...B	-	-	-	○	○	○	○	○	
High carbon steel made	Standard 	Ball retained type	LWLF...BCS	-	-	-	-	○	○	○	○	
Tapped rail specification Mounting from bottom 	Stainless steel made	Short 	Ball retained type	MLFC...N	-	-	○	○	○	-	-	-
				LWLF...N	-	-	○	○	○	-	-	-
		Ball non-retained type	MLFC...N	-	○	-	-	-	-	-	-	-
			LWLF...N	-	○	-	-	-	-	-	-	-
		Standard 	Ball retained type	MLF...N	-	-	○	○	○	-	-	-
				LWLF...N	-	-	○	○	○	-	-	-
	Ball non-retained type	MLF...N	-	○	-	-	-	-	-	-	-	
		LWLF...N	-	○	-	-	-	-	-	-	-	
	Long 	Ball retained type	MLFG...N	-	-	-	○	○	-	-	-	
			LWLF...N	-	-	-	○	○	-	-	-	

Remark: For the models indicated in  , the interchangeable specification is available.

Table 3.1 Standard and maximum length of stainless steel track rail (Standard type)



unit: mm

Item	Identification number	Standard type					
		LWL1...Y	LWL1	LWL2	ML 3 LWL3	ML 5 LWL5...B	ML 7 LWL7...B
Standard length $L$ ( $n$ )		18 ( 3)	18 ( -)	32 ( 4)	30 ( 3)	60 ( 4)	60 ( 4)
		30 ( 5)	30 ( -)	40 ( 5)	40 ( 4)	90 ( 6)	90 ( 6)
		42 ( 7)	42 ( -)	56 ( 7)	60 ( 6)	105 ( 7)	120 ( 8)
				80 ( 10)	80 ( 8)	120 ( 8)	150 ( 10)
Pitch of mounting holes $F$		6	-	8	10	15	15
$E$		3	-	4	5	7.5	7.5
Standard $E$ or higher dimensions <sup>(1)</sup>	below	2.5	-	2.5	3	4	4.5
	above	5.5	-	6.5	8	11.5	12
Maximum length <sup>(2)</sup>		102	102	104 (200)	150 (300)	210 (510)	300 (990)
Maximum number of butt-jointing track rail <sup>(3)</sup>		-	-	-	-	5	7
Maximum length of butt-jointing track rail <sup>(3)</sup>		-	-	-	-	915	1 905
Item	Identification number	Standard type					
		ML 9 LWL9...B	ML 12 LWL12...B	ML 15 LWL15...B	ML 20 LWL20...B	ML 25 LWL25...B	
Standard length $L$ ( $n$ )		60 ( 3)	100 ( 4)	160 ( 4)	180 ( 3)	240 ( 4)	
		80 ( 4)	150 ( 6)	240 ( 6)	240 ( 4)	300 ( 5)	
		120 ( 6)	200 ( 8)	320 ( 8)	320 ( 6)	360 ( 6)	
		160 ( 8)	275 ( 11)	440 ( 11)	480 ( 8)	480 ( 8)	
		220 ( 11)	350 ( 14)	560 ( 14)	660 ( 11)	660 ( 11)	
	280 ( 14)	475 ( 19)	680 ( 17)	840 ( 14)	900 ( 15)		
Pitch of mounting holes $F$		20	25	40	60	60	
$E$		10	12.5	20	30	30	
Standard $E$ or higher dimensions <sup>(1)</sup>	below	4.5	5	5.5	8	9	
	above	14.5	17.5	25.5	38	39	
Maximum length <sup>(2)</sup>		860 (1 200)	1 000 (1 450)	1 000 (1 480)	960 (1 800)	960 (1 800)	
Maximum number of butt-jointing track rail <sup>(3)</sup>		2	2	2	2	2	
Maximum length of butt-jointing track rail <sup>(3)</sup>		1 660	1 925	1 880	1 740	1 740	

Notes <sup>(1)</sup> Not applicable to track rail with stopper pins (supplemental code "S").

<sup>(2)</sup> Length up to the value in ( ) can be produced. If needed, please contact **IKO**.

<sup>(3)</sup> Not applicable to interchangeable specifications or tapped rail specifications.

Remarks 1. A typical identification number is indicated, but is applied to all models of the same size.

2. Indicate "LWL...B" for the model code of the single track rail regardless of the series and the combination of slide unit models.

3. If not directed,  $E$  dimensions for both ends will be the same within the range of standard  $E$  dimensions. To change the dimensions, indicate the specified rail mounting hole positions "/ $E$ " of special specification. For more information, see page III-30.



Table 3.2 Standard and maximum length of stainless steel track rail (Wide type)

Item	Identification number	LWLF4	MLF 6 LWLF6	MLF 10 LWLF10...B	MLF 14 LWLF14...B
Standard length $L$ (n)		40 ( 4)	60 ( 4)	60 ( 3)	90 ( 3)
		60 ( 6)	90 ( 6)	80 ( 4)	120 ( 4)
		70 ( 7)	105 ( 7)	120 ( 6)	150 ( 5)
		80 ( 8)	120 ( 8)	160 ( 8)	180 ( 6)
		100 (10)	150 (10)	220 (11)	240 ( 8)
Pitch of mounting holes $F$		10	15	20	30
$E$		5	7.5	10	15
Standard $E$ dimensions (1)	or higher	3.5	4.5	4.5	5.5
	below	8.5	12	14.5	20.5
Maximum length (2)		180 (300)	240 (300)	300 (500)	300 (990)
Maximum number of butt-jointing track rail (3)		—	—	7	8
Maximum length of butt-jointing track rail (3)		—	—	1 840	1 950
Item	Identification number	MLF 18 LWLF18...B	MLF 24 LWLF24...B	MLF 30 LWLF30...B	MLF 42 LWLF42...B
Standard length $L$ (n)		90 ( 3)	120 ( 3)	160 ( 4)	160 ( 4)
		120 ( 4)	160 ( 4)	240 ( 6)	240 ( 6)
		150 ( 5)	240 ( 6)	320 ( 8)	320 ( 8)
		180 ( 6)	320 ( 8)	440 (11)	440 (11)
		240 ( 8)	400 (10)	560 (14)	560 (14)
	300 (10)	480 (12)	680 (17)	680 (17)	
Pitch of mounting holes $F$		30	40	40	40
$E$		15	20	20	20
Standard $E$ dimensions (1)	or higher	5.5	6.5	6.5	6.5
	below	20.5	26.5	26.5	26.5
Maximum length (2)		690 (1 860)	680 (1 960)	680 (2 000)	680 (2 000)
Maximum number of butt-jointing track rail (3)		3	3	3	3
Maximum length of butt-jointing track rail (3)		1 920	1 840	1 840	1 840

Notes (1) Not applicable to track rail with stopper pins (supplemental code "/S").

(2) Length up to the value in ( ) can be produced. If needed, please contact **IKO**.

(3) Not applicable to interchangeable specifications or tapped rail specifications.

Remarks 1. A typical identification number is indicated, but is applied to all models of the same size.

2. Indicate "LWLF...B" for the model code of the single track rail regardless of the series and the combination of slide unit models.

3. If not directed,  $E$  dimensions for both ends will be the same within the range of standard  $E$  dimensions. To change the dimensions, indicate the specified rail mounting hole positions "/E" of special specification. For more information, see page III-30.

Table 3.3 Standard and maximum length of high carbon steel track rail (Standard type, Wide type)

Item	Identification number	LWLF 9...BCS	LWLF12...BCS	LWLF15...BCS	LWLF20...BCS
Standard length $L$ (n)		80 ( 4)	100 ( 4)	160 ( 4)	180 ( 3)
		160 ( 8)	200 ( 8)	320 ( 8)	240 ( 4)
		220 (11)	275 (11)	440 (11)	360 ( 6)
		280 (14)	350 (14)	560 (14)	480 ( 8)
		380 (19)	475 (19)	680 (17)	660 (11)
		500 (25)	600 (24)	800 (20)	900 (15)
	600 (30)	700 (28)	920 (23)	1 020 (17)	
Pitch of mounting holes $F$		20	25	40	60
$E$		10	12.5	20	30
Standard $E$ dimensions (1)	or higher	4.5	5	5.5	8
	below	14.5	17.5	25.5	38
Maximum length		1 000	1 500	1 520	1 560
Item	Identification number	LWLF18...BCS	LWLF24...BCS	LWLF30...BCS	LWLF42...BCS
Standard length $L$ (n)		90 ( 3)	120 ( 3)	160 ( 4)	160 ( 4)
		180 ( 6)	240 ( 6)	320 ( 8)	320 ( 8)
		240 ( 8)	320 ( 8)	440 (11)	440 (11)
		300 (10)	400 (10)	560 (14)	560 (14)
		420 (14)	600 (15)	680 (17)	680 (17)
		510 (17)	720 (18)	800 (20)	800 (20)
	600 (20)	800 (20)	920 (23)	920 (23)	
Pitch of mounting holes $F$		30	40	40	40
$E$		15	20	20	20
Standard $E$ dimensions (1)	or higher	5.5	6.5	6.5	6.5
	below	20.5	26.5	26.5	26.5
Maximum length		1 500	1 520	1 600	1 600

Note (1) Not applicable to track rail with stopper pins (supplemental code "/S").

Remarks 1. A typical identification number is indicated, but is applied to all models of the same size.

2. If not directed,  $E$  dimensions for both ends will be the same within the range of standard  $E$  dimensions. To change the dimensions, indicate the specified rail mounting hole positions "/E" of special specification. For more information, see page III-30.

— Preload Amount —

<b>8 Preload amount</b>	Clearance	: T <sub>0</sub>	Specify this item for an assembled set or a single slide unit. For details of the preload amount, see Table 4. For applicable preload types, see Table 5.1 and Table 5.2.
	Standard	: No symbol	
	Light preload	: T <sub>1</sub>	

**Table 4 Preload amount**

Preload type	Item	Preload symbol	Preload amount N	Operational conditions
Clearance		T <sub>0</sub>	0 <sup>(1)</sup>	• Very light motion
Standard		(No symbol)	0 <sup>(2)</sup>	• Light and precise motion
Light preload		T <sub>1</sub>	0.02 C <sub>0</sub>	• Almost no vibrations • Load is evenly balanced • Light and precise motion

Notes <sup>(1)</sup> There is zero or subtle clearance.

<sup>(2)</sup> Indicates zero or minimal amount of preload.

Remark: C<sub>0</sub> indicates the basic static load rating.

**Table 5.1 Application of preload (Standard type)**

Size	Preload type (preload symbol)		
	Clearance (T <sub>0</sub> )	Standard (No symbol)	Light preload (T <sub>1</sub> )
1	○	—	—
2	○	—	—
3	○	—	—
5	○	○	—
7	○ <sup>(1)</sup>	○	○ <sup>(1)</sup>
9	○ <sup>(1)</sup>	○	○ <sup>(1)</sup>
12	○ <sup>(1)</sup>	○	○ <sup>(1)</sup>
15	○ <sup>(1)</sup>	○	○ <sup>(1)</sup>
20	○	○	○
25	○	○	○

Note <sup>(1)</sup> Not applicable when /HB is specified.

Remark: The mark  indicates that interchangeable specification products are available.

**Table 5.2 Application of preload (Wide type)**

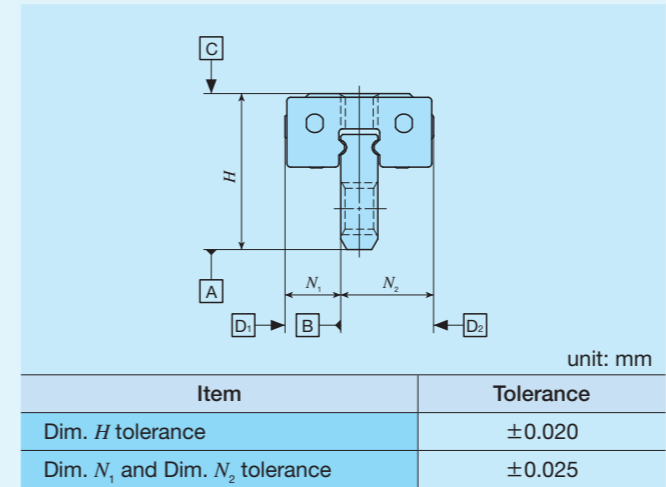
Size	Preload type (preload symbol)		
	Clearance (T <sub>0</sub> )	Standard (No symbol)	Light preload (T <sub>1</sub> )
4	○	—	—
6	○	—	—
10	○	○	—
14	○	○	○
18	○	○	○
24	○	○	○
30	○	○	○
42	○	○	○

Remark: The mark  indicates that interchangeable specification products are available.

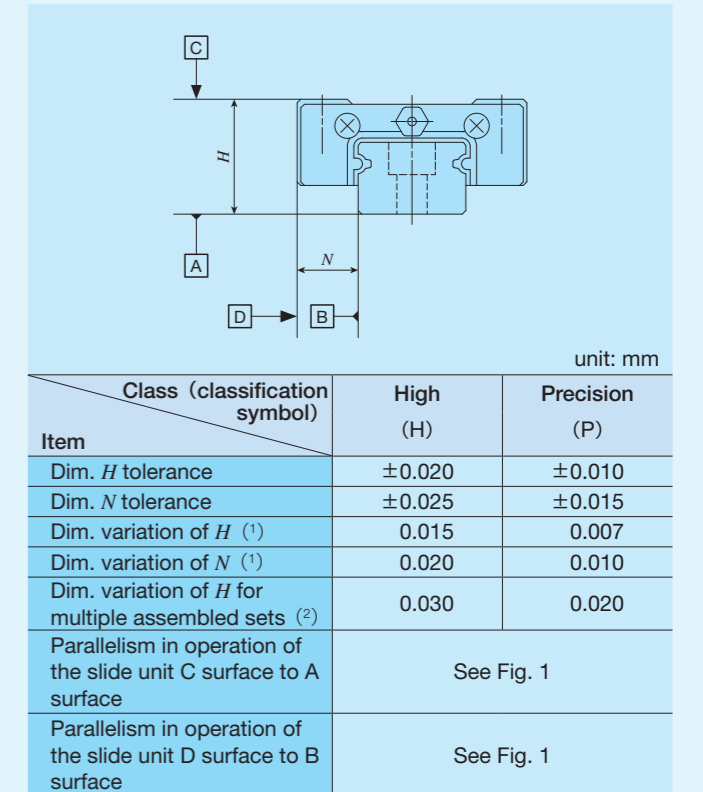
— Accuracy class —

<b>9 Accuracy class</b>	High	: H	For interchangeable specification products, assemble a slide unit and a track rail of the same accuracy class. Size 1 series have "No symbols." For the details of accuracy class, see Table 6.1 and 6.2.
	Precision	: P	

**Table 6.1 Tolerance and allowable values (Series of size 1)**

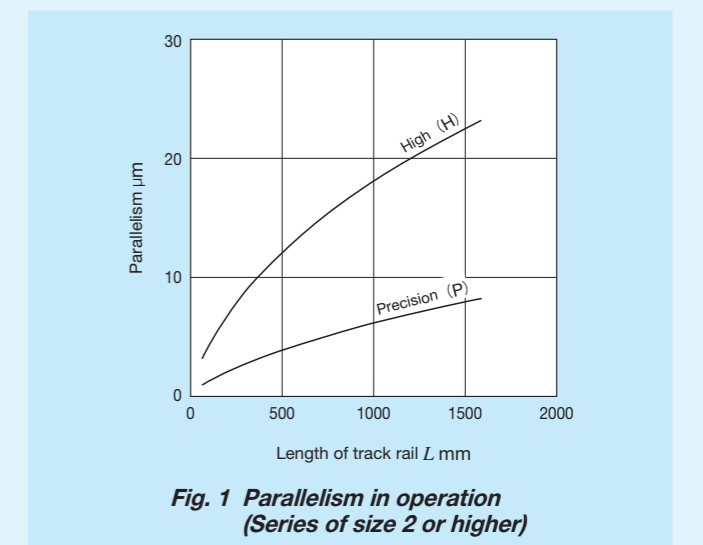


**Table 6.2 Tolerance and allowance (Series of size 2 or higher)**



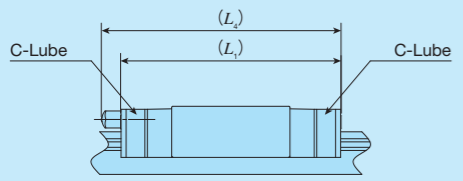
Notes <sup>(1)</sup> It means the size variation between slide units mounted on the same track rail.

<sup>(2)</sup> Applicable to the interchangeable specification.





**Table 9 Dimension of slide unit with C-Lube plate (Supplemental code /Q)**



unit: mm

Identification number	$L_1$	$L_4$	Identification number	$L_1$	$L_4$
LWLC 5...B	22	—	LWLFC 10...B	26.5	—
LWL 5...B	25	—	LWLF 10...B	30.5	—
LWLC 7...B	27	—	LWLFC 14...B	30.5	—
LWL 7...B	31.5	—	LWLF 14...B	39.5	—
LWLG 7...B	39	—	LWLFG 14...B	50	—
LWLC 9...B	30	—	LWLFC 18...B	34.5	—
LWL 9...B	39	—	LWLF 18...B	46.5	—
LWLG 9...B	49	—	LWLFG 18...B	58.5	—
LWLC 12...B	33	—	LWLFC 24...B	38.5	—
LWL 12...B	42	—	LWLF 24...B	52	—
LWLG 12...B	52	—	LWLFG 24...B	67	—
LWLC 15...B	42	47	LWLFC 30...B	45.5	50
LWL 15...B	52	57	LWLF 30...B	59.5	64
LWLG 15...B	67	72	LWLFG 30...B	78.5	83
LWLC 20...B	48	53	LWLFC 42...B	51.5	56
LWL 20...B	60	65	LWLF 42...B	65	70
LWLG 20...B	78	83	LWLFG 42...B	84.5	89
LWLC 25...B	63.5	74			
LWL 25...B	87.5	98			
LWLG 25...B	107.5	117			

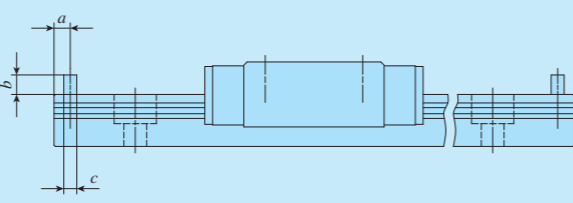
Remarks 1. The dimensions of the slide unit with C-Lube at both ends are indicated.  
 2. A typical identification number is indicated, but is applied to all LWL(F) series models of the same size.

**Table 10 Load rating / static moment rating of Hybrid C-Lube Linear Way (Supplemental code /HB)**

Identification number	C N	$C_0$ N	$T_0$ N·m	$T_x^{(1)}$ N·m	$T_y^{(1)}$ N·m
MLC 7.../HB	937	965	3.5	1.6 12.6	1.3 10.6
ML 7.../HB	1 330	1 610	5.9	4.0 23.9	3.3 20.1
MLG 7.../HB	1 690	2 250	8.2	7.5 43.1	6.3 36.2
MLC 9.../HB	1 180	1 260	5.9	2.4 18.2	2.1 15.3
ML 9.../HB	1 810	2 340	10.9	7.7 43.4	6.5 36.4
MLG 9.../HB	2 370	3 420	15.9	15.9 83.6	13.4 70.1
MLL 9.../HB	2 870	4 500	20.9	27.1 134	22.7 112
MLC 12.../HB	2 210	2 030	12.6	4.5 35.5	3.8 29.8
ML 12.../HB	3 330	3 650	22.6	13.1 79.2	11.0 66.4
MLG 12.../HB	4 310	5 270	32.7	26.0 143	21.9 120
MLL 12.../HB	5 820	8 110	50.3	59.3 288	49.8 242
MLC 15.../HB	3 490	3 310	25.5	9.9 71.8	8.3 60.3
ML 15.../HB	4 980	5 520	42.5	25.3 146	21.2 122
MLG 15.../HB	6 620	8 280	63.7	54.3 288	45.5 241
MLL 15.../HB	8 370	11 600	89.2	104 497	86.9 417

Note (1) The upper values of  $T_x$  and  $T_y$  are for one slide unit and the lower values are for two slide units in close contact.

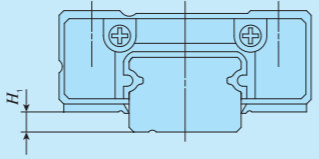
**Table 11 Dimension of track rail with stopper pins (Supplemental code /S)**



unit: mm

Size	$a$	$b$	$c$
5	—	2	1.6
7	—	2.5	2
9	—	3	2
—	10	2	1.6
12	—	3	2
—	14	3	2
15	—	4	2
—	18	3	2
20	—	5	2
—	24	3	2
25	—	5	2
—	30	4	2
—	42	5	2

**Table 12  $H_1$  dimension with under seal (Supplemental code /U)**



unit: mm

Size	$H_1$
9	—
12	—
15	—
—	18
20	—
—	24
25	—
—	30
—	42

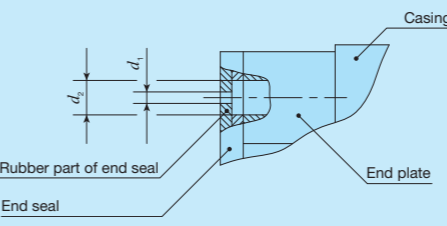
Note (1) The dimensions are the same as those before mounting of under seal.

## Lubrication

Lithium-soap base grease (MULTEMP PS No.2 [KYODO YUSHI CO., LTD.]) is pre-packed in ML(F) and LWL(F) series. Additionally, ML(F) series has C-Lube placed in the recirculation part of balls, so that the interval for reapplying lubricant can be extended and maintenance works such as grease job can be reduced significantly.

ML(F) series and LWL(F) series have grease nipple or oil hole as indicated in Table 14. Since the Size 1, 2, 3, 4 and 6 series do not have an oil hole, apply grease directly to the raceway part of the track rail for re-greasing. Supply nozzles fit to each shapes of grease nipple and dedicated supplying equipment (miniature greasers) fit to oil holes are also available. For order of these parts for lubrication, see Table 13 and Table 14.1 on Page III-23, and Table 15 on page III-24.

**Table 13 Oil hole specifications**



unit: mm

Size	$d_1$	$d_2$
5	10	1.1
7	14	1.2
9	18	1.5
12	24	2

**Table 14 Parts for lubrication**

Size	Grease nipple type (1)	Applicable supply nozzle type	Bolt size of female threads for piping
5, 7, 9, 12	Oil hole	Miniature greaser	—
15, 20	A-M3	A-5120V A-5240V B-5120V B-5240V	—
25	B-M4	A-8120V B-8120V	M4

Note (1) For grease nipple specification, see Table 14.1 on page III-23.

Remark: Stainless steel grease nipple is also available. If needed, please contact **IKO**.

## Dust Protection

The slide units of ML(F) series and LWL(F) series are equipped with end seals as standard for dust protection. However, if large amount of contaminant or dust are floating, or if large particles of foreign substances such as chips or sand may adhere to the track rail, it is recommended to attach a protective cover to the linear motion mechanism.

No end seal is provided for size 1, 2, 3, 4 or 6 series. For applications in the environment not clean enough, cover the entire unit with a protective case, etc. to prevent harmful foreign substances such as dust and particles from outside to enter.





# Precaution for Use

## ① Mounting surface, reference mounting surface and general mounting structure

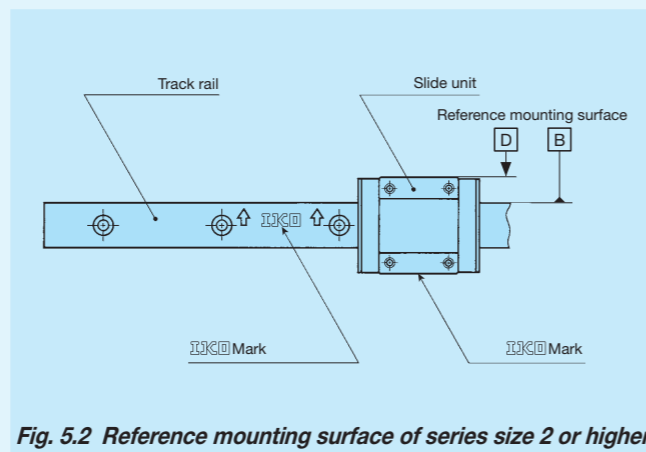
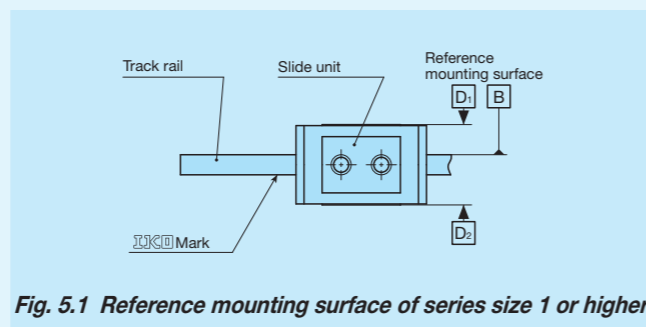
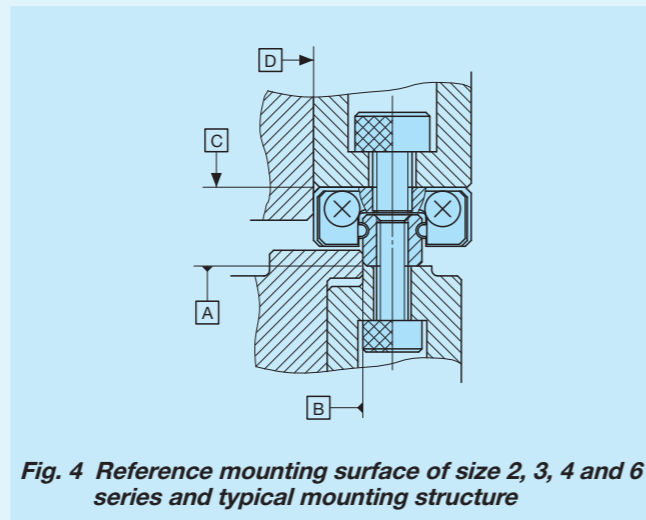
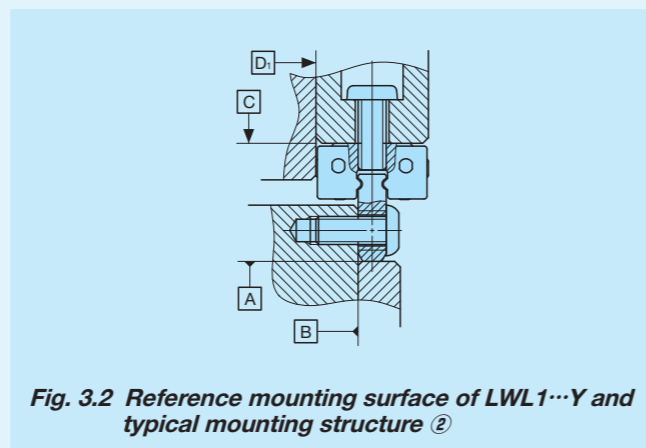
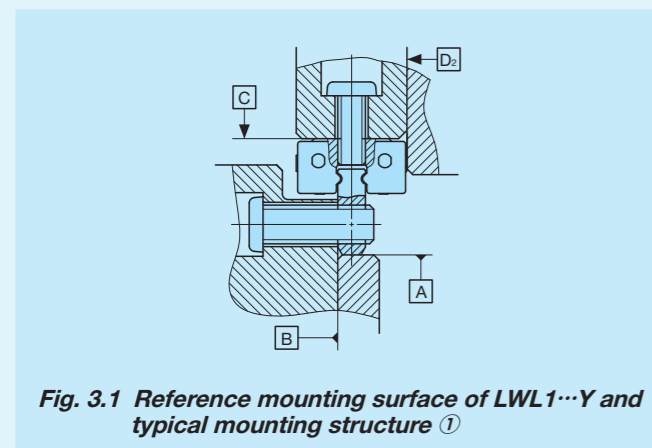
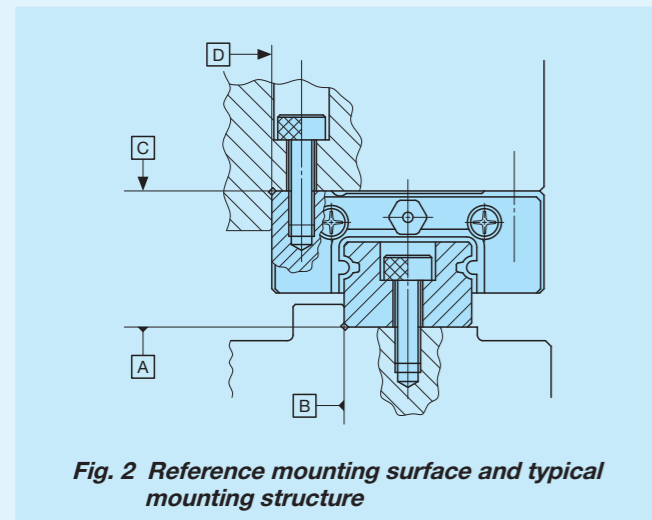
When mounting the ML(F) series and LWL(F) series, properly align the reference mounting surfaces B and D (D1 or D2) of the track rail and slide unit with the reference mounting surface of the table and bed and fix them. (See Fig. 2)

Reference mounting surfaces B and D (D1 or D2) and mounting surfaces A and C are precisely ground. By machining the mounting surface of the mating member, such as machine or device, to high accuracy and mounting them properly, stable linear motion with high accuracy is obtained.

Reference mounting surface of the slide unit of size 2 or higher is the opposite side of the  mark. The track rail reference mounting surface is identified by locating the  mark on the top surface of the track rail. It is the side surface above the mark (in the direction of the arrow). (See Fig. 5.2)

Reference mounting surface of the slide unit of size 1 is located at both right and left sides (D1 and D2). (See Fig. 5.1)

The track rail of LWL1...Y has the mounting structure of lateral direction. Two types of mounting structure as shown in Fig. 3.1 and Fig. 3.2 are available.



## ② Mounting screws for slide unit

To mount a slide unit, tightly fasten the bolt against female thread of slide unit.

The female thread is created through holes of the slide unit for size 1 series, and also through holes for the slide unit and track rail for size 2, 3, 4 and 6 series. When the fixing thread depth of the mounting screw goes too deep, it can interfere with the track rail and impact the running accuracy or product life so that the fixing thread depth should be within the screwing depth specified in the dimension table.

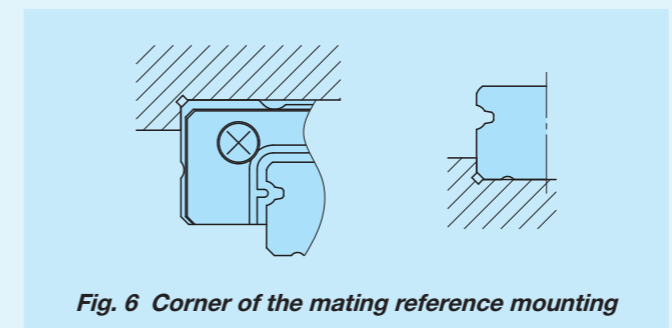
Also prepare the small screws dedicated to precision devices (head diameter 1.8 mm or smaller) for the mounting bolt of slide unit of size 1.

## ③ Mounting screws for track rail

In the size 2 and 3 series and tapped rail specifications, track rail mounting bolts are not appended. Prepare mounting bolts whose fixing thread depth is less than  $H_4$  in dimension table.

## ④ Shoulder height and corner radius of the reference mounting surface

For the opposite corner of the mating reference mounting, it is recommended to have relieved fillet as indicated in Fig. 6. Recommended value for the shoulder height on the mating side is indicated in Table 16.



## ⑤ Tightening torque for fixing screw

Typical tightening torque for mounting ML(F) series and LWL(F) series to the steel mating member material is indicated in Table 15. When vibration and shock of the machine or device are large, fluctuating load is large, or moment load is applied, fix it by using the torque 1.2 to 1.5 times larger than the value indicated in the table as necessary. If the mating member material is cast iron or aluminum alloy, reduce the tightening torque depending on the strength characteristics of the mating member material.

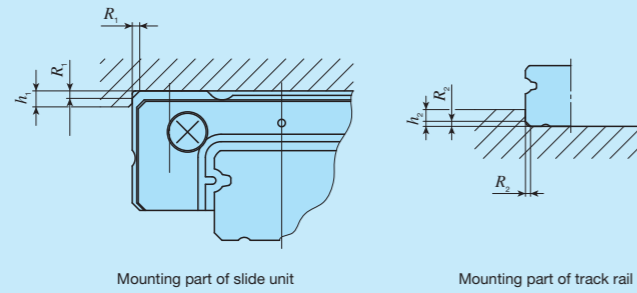
Table 15 Tightening torque for fixing screw

Bolt size	Tightening torque N · m	
	Stainless steel-made screw	High carbon steel-made screw
M1 ×0.25	0.04	—
M1.4×0.3	0.10	—
M1.6×0.35	0.15	—
M2 ×0.4	0.31	—
M2.5×0.45	0.62	—
M3 ×0.5	1.1	1.3
M4 ×0.7	2.5	2.9
M5 ×0.8	5.0	5.7
M6 ×1	8.5	—

Remarks 1. The tightening torque is calculated based on strength division 8.8 and property division A2-70.

2. It is recommended that the tightening torque of slide unit mounting holes for series size 1 is to be 70 to 80 % of the values in the table.

Table 16 Shoulder height and corner radius of the reference mounting surface



unit: mm

Identification number		Mounting part of slide unit		Mounting part of track rail	
		Shoulder height $h_1$	Corner radius $R_1$ (Maximum)	Shoulder height $h_2$ <sup>(1)</sup>	Corner radius $R_2$ (Maximum)
—	LWL 1··Y	1.3	—	2	—
—	LWL 1			—	
—	LWL 2	1	0.1	0.5	0.05
ML 3	LWL 3	1.2	0.15	0.8	0.1
ML 5	LWL 5··B	2	0.3	0.8	0.2
ML 7	LWL 7··B	2.5	0.2	1.2	0.2
ML 9	LWL 9··B	3	0.2	1.5	0.2
—	LWL 9··BCS		0.4		
ML 12	LWL 12··B	4	0.2	2.5	0.2
—	LWL 12··BCS		0.4		
ML 15	LWL 15··B	4.5	0.2	3	0.2
—	LWL 15··BCS		0.4		
ML 20	LWL 20··B	5	0.2	4	0.2
—	LWL 20··BCS		0.4		
ML 25	LWL 25··B	6.5	0.7	4	0.7
—	LWLF 4	1.5	0.1	0.8	0.1
MLF 6	LWLF 6	2	0.1	0.8	0.1
MLF 10	LWLF 10··B	2	0.3	1.2	0.2
MLF 14	LWLF 14··B	2.5	0.2	1.2	0.2
MLF 18	LWLF 18··B	3	0.2	2.5	0.2
—	LWLF 18··BCS		0.4		
MLF 24	LWLF 24··B	4	0.2	2.5	0.2
—	LWLF 24··BCS		0.4		
MLF 30	LWLF 30··B	4.5	0.2	2.5	0.2
—	LWLF 30··BCS		0.4		
MLF 42	LWLF 42··B	5	0.2	3	0.2
—	LWLF 42··BCS		0.4		

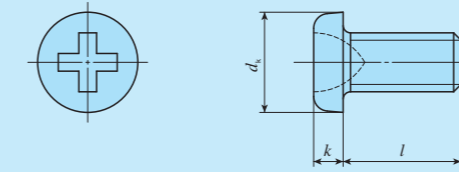
Note <sup>(1)</sup> For models with under seals (supplemental code "U"), it is recommended to use the values 1mm smaller than the values in the table. However for the models of size 9 with under seal, 0.8 mm is recommended.

Remark: A typical identification number is indicated, but is applied to all models of the same size.

## Mounting Bolt

For LWL(F) series, track rail mounting bolt of slide unit and tapped rail specification shown in Table 17 and Table 18 are available. If these parts are necessary, please contact **IKO**.

Table 17 Cross-recessed pan head screw for precision equipment



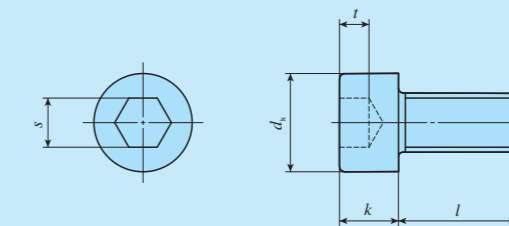
unit: mm

Bolt size $(d)$	Pitch of screw $P$	$d_k$	$k$	$l$
M1	0.25	1.8	0.45	3, 4, 5
M1.4 <sup>(1)</sup>	0.3	2.5	0.8	2.5, 3, 4
M1.6 <sup>(1)</sup>	0.35	2.8	0.85	4, 5, 6
M2 <sup>(1)</sup>	0.4	3.5	1	3, 4, 5

Note <sup>(1)</sup> Based on cross-recessed head screw for precision equipment (Number 0) in Japan Camera Industry Standard JCIS 10-70.

Remark: The dimensions are different from the appended track rail mounting bolts.

Table 18 Hexagon socket head bolt



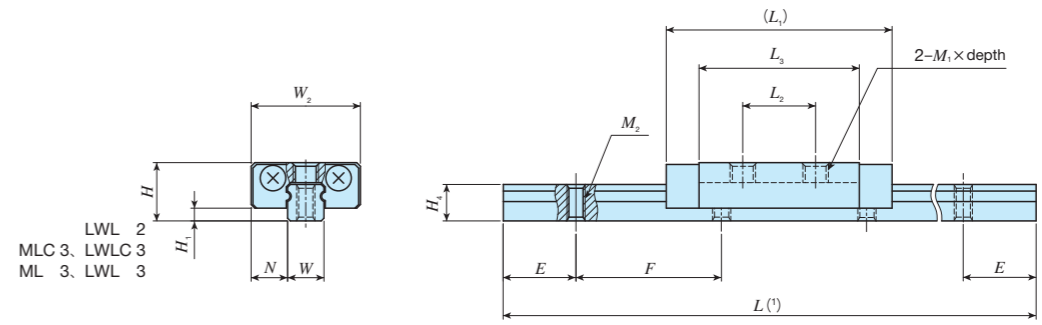
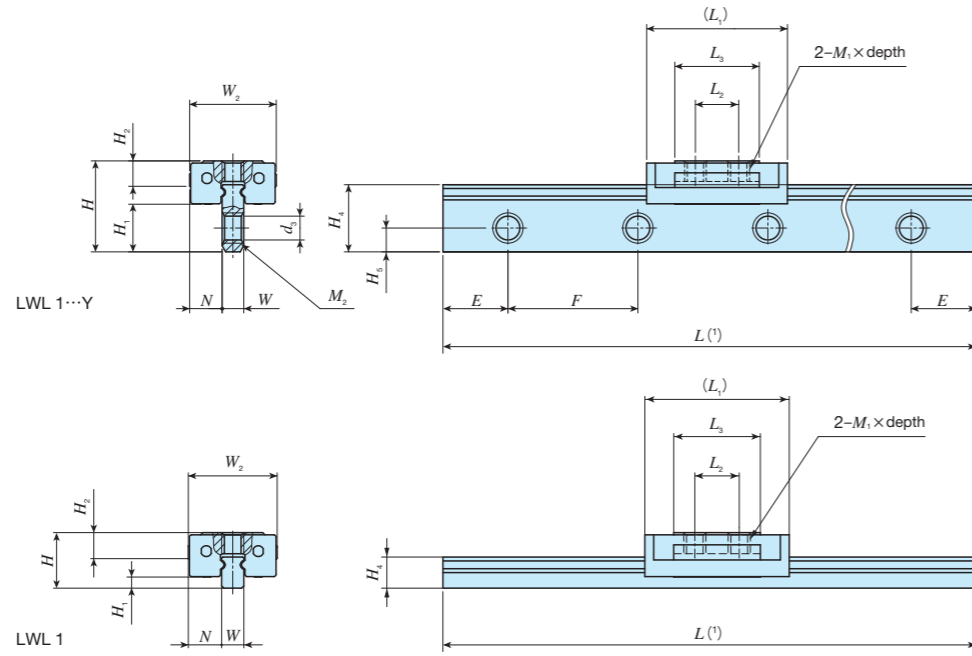
unit: mm

Bolt size $(d)$	Pitch of screw $P$	$d_k$	$k$	$s$	$t$	$l$
M1.4	0.3	2.6	1.4	1.3	0.6	2.5, 3, 4
M1.6 <sup>(1)</sup>	0.35	3	1.6	1.5	0.7	4, 5, 6
M2 <sup>(1)</sup>	0.4	3.8	2	1.5	1	3, 4, 5

Note <sup>(1)</sup> Based on hexagon socket head bolts equivalent to JIS B 1176.

# IKO C-Lube Linear Way ML

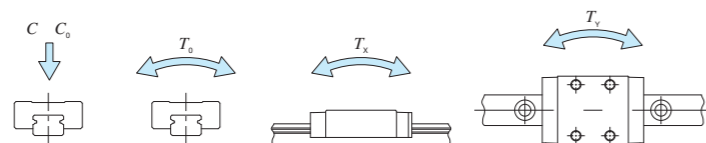
Standard type											
Shape	ML • LWL										
Size	<table border="1"> <tr> <td>1</td><td>2</td><td>3</td><td>5</td><td>7</td> </tr> <tr> <td>9</td><td>12</td><td>15</td><td>20</td><td>25</td> </tr> </table>	1	2	3	5	7	9	12	15	20	25
1	2	3	5	7							
9	12	15	20	25							



Identification number	Interchangeable	Mass (Ref.) g		Dimensions of assembly mm			Dimensions of slide unit mm							Dimensions of track rail mm						Mounting bolt for track rail (2) mm	Basic dynamic load rating (5) C N	Basic static load rating (5) C0 N	Static moment rating (5)				
		Slide unit	Track rail (per 100 mm)	H	H1	N	W2	L1	L2	L3	M1 × depth	H2	W	H4	H5	M2	d3	E	F				T0 N · m	Tx N · m	Ty N · m		
—	LWL 1...Y	—	0.16	2.1	4.2	2.2	1.5	4	6.5	2	3.9	M1 × 0.9	1.2	1	3.1	1.1	M1.4 Through	1.1	3	6	M1 × ℓ or M1.4 × ℓ (3)	66.8	113	0.06	0.07 0.47	0.09 0.56	
—	LWL 1	—	—	1.0	2.5	0.5	—	—	—	—	—	—	—	—	1.4	—	—	—	—	—	—	—	—	—	—	—	—
—	LWL 2	—	0.9	2.8	3.2	0.7	2	6	12.5	4	8.8	M1.4 × 1.1	—	2	2	—	M1 Through	—	4	8	M1 × ℓ (4)	211	381	0.42	0.54 2.9	0.64 3.5	
MLC 3	LWLC 3	—	0.9	5.3	4	1	2.5	8	10.5	3.5	7	M1.6 × 1.3	—	3	2.6	—	M1.6 Through	—	5	10	M1.6 × ℓ (4)	272	406	0.65	0.49 2.7	0.58 3.2	
—	LWL 3	—	1.0						11.5		6.7											371	632	1.0	1.1 5.6	1.3 6.6	
ML 3	LWL 3	—	1.3	14.5	5.5	11	M2 × 1.3	—	3	2.6	—	M1.6 Through	—	5	10	M1.6 × ℓ (4)	—	5	10	M1.6 × ℓ (4)	353	587	0.94	0.98 5.6	1.2 6.7		
—	LWL 3	—	1.6	15.5																	10.7	371	632	1.0	1.1 5.6	1.3 6.6	

Notes (1) Track rail lengths  $L$  are shown in Table 3.1 on page II-10.  
 (2) Track rail mounting bolts are not appended.  
 (3) Prepare screws according to mounting structure.  
 (4) Choose screws whose dimension allow fixing thread depth into track rail  $\ell$  to be less than  $H_4$ .  
 (5) The direction of basic dynamic load rating ( $C$ ), basic static load rating ( $C_0$ ), and static moment rating ( $T_0$ ,  $T_x$ ,  $T_y$ ) are shown in the sketches below.  
 The upper values of  $T_x$  and  $T_y$  are for one slide unit and the lower values are for two slide units in close contact.

Remarks 1. Metal parts are made of stainless steel.  
 2. Do not disassemble a slide unit from the track rail because steel balls are not retained. No end seal is attached.  
 3. The specification of small size mounting bolts (M2 and less) are show on page II-22. If needed, please contact IKO.



## Example of identification number of assembled set

Model code	Dimensions	Part code	Model code	Preload symbol	Classification symbol	Supplemental code
LWL	2	C2 R80		T0	P	/D
①	②	③	④	⑤	⑥	⑦

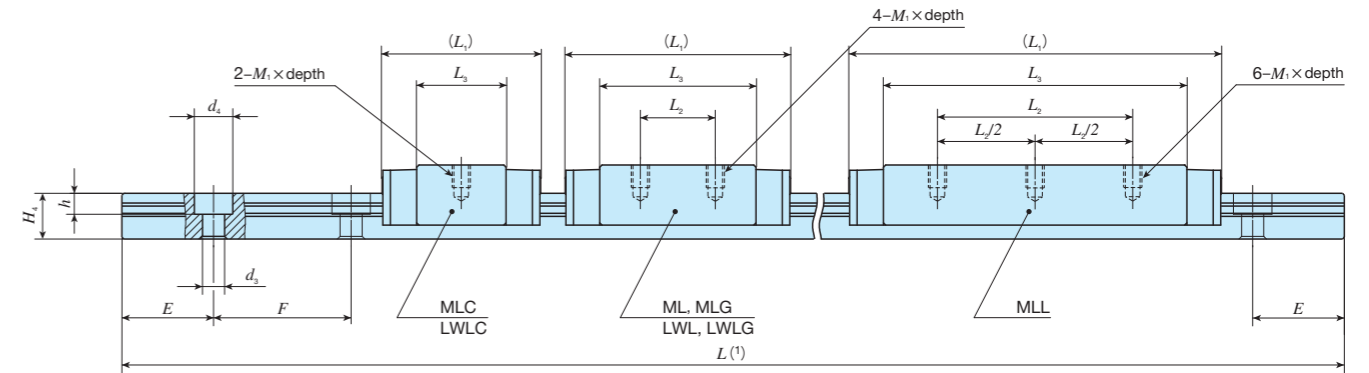
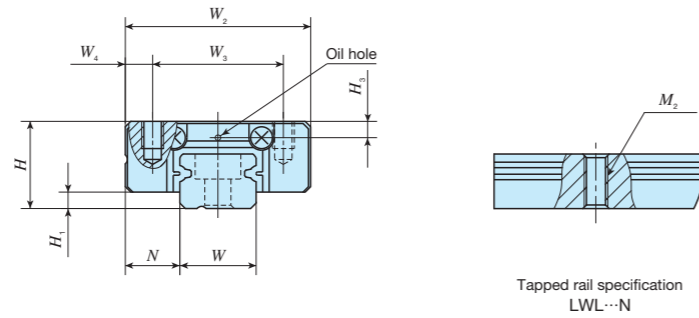
① Model	③ Size	⑥ Preload amount	⑧ Special specification
ML LWL LWL...Y	1, 2, 3	T0 Clearance	BS, D, E, I, W, Y
② Length of slide unit	④ Number of slide unit (2)	⑦ Accuracy class	
C No symbol		No symbol H P	Ordinary High Precision
Standard	⑤ Length of track rail (80 mm)		





# IKO C-Lube Linear Way ML

Standard type						
Shape	ML • LWL					
Size	1	2	3	5	7	
	9	12	15	20	25	



Identification number	ML series	LWL series (No C-Lube)	Interchangeable	Mass (Ref.) g		Dimensions of assembly mm			Dimensions of slide unit mm						Dimensions of track rail mm						Appended mounting bolt for track rail mm Bolt size × ℓ	Basic dynamic load rating <sup>(4)</sup> C N	Basic static load rating <sup>(4)</sup> C <sub>0</sub> N	Static moment rating <sup>(4)</sup>							
				Slide unit	Track rail (per 100 mm)	H	H <sub>1</sub>	N	W <sub>2</sub>	W <sub>3</sub>	W <sub>4</sub>	L <sub>1</sub>	L <sub>2</sub>	L <sub>3</sub>	M <sub>1</sub> × depth	H <sub>3</sub>	W	H <sub>4</sub>	M <sub>2</sub>	d <sub>3</sub>				d <sub>4</sub>	h	E	F	T <sub>0</sub> N · m	T <sub>x</sub> N · m	T <sub>y</sub> N · m	
MLC 9	9	LWLC 9··B	○	11	35													9	6	-	3.5	6	3.5				1 180	1 480	6.9	2.9	2.4
MLC 9··N*	9··N*	LWLC 9··N*	-	11	37					21.5	-	11.9						9	6	M4 Through	-	-	-				1 180	1 480	6.9	2.9	2.4
ML 9	9	LWL 9··B	○	18	35													9	6	-	3.5	6	3.5				1 810	2 760	12.8	9.1	7.6
-	-	LWL 9··BCS	○	19	35					30	10	20.8						9	6	-	3.5	6	3.5				1 810	2 760	12.8	9.1	7.6
ML 9··N*	9··N*	LWL 9··N*	-	18	37	10	2	5.5	20	15	2.5							9	6	M4 Through	-	-	-				1 810	2 760	12.8	9.1	7.6
MLG 9	9	LWLG 9··B	○	26	35													9	6	-	3.5	6	3.5				2 370	4 030	18.7	18.7	15.7
MLG 9··N*	9··N*	LWLG 9··N*	-	26	37					40.5	15	30.9						9	6	M4 Through	-	-	-				2 370	4 030	18.7	18.7	15.7
MLL 9	9	-	○	34	35					50	26	40.4						9	6	-	3.5	6	3.5				2 870	5 300	24.6	31.9	26.7
MLL 9··N*	9··N*	-	-	34	37					50	26	40.4						9	6	M4 Through	-	-	-				2 870	5 300	24.6	31.9	26.7
MLC 12	12	LWLC 12··B	○	22	35					25	-	13						12	8	-	3.5	6.5	4.5	12.5	25		2 210	2 380	14.8	5.3	4.5
ML 12	12	LWL 12··B	○	34	35					34	15	21.6						12	8	-	3.5	6.5	4.5	12.5	25		3 330	4 290	26.6	15.4	12.9
-	-	LWL 12··BCS	○	35	35	13	3	7.5	27	20	3.5							12	8	-	3.5	6.5	4.5	12.5	25		3 330	4 290	26.6	15.4	12.9
MLG 12	12	LWLG 12··B	○	48	35					44	20	32						12	8	-	3.5	6.5	4.5	12.5	25		4 310	6 200	38.4	30.6	25.7
MLL 12	12	-	○	70	35					59.5	30	47.3						12	8	-	3.5	6.5	4.5	12.5	25		5 820	9 540	59.1	69.8	58.6
MLL 12	12	-	○	70	37					59.5	30	47.3						12	8	-	3.5	6.5	4.5	12.5	25		5 820	9 540	59.1	69.8	58.6

Notes <sup>(1)</sup> Track rail lengths  $L$  are shown in Table 3.1 on page II - 10 and Table 3.3 on page II - 12.

<sup>(2)</sup> The appended track rail mounting bolts are hexagon socket head bolts equivalent to JIS B 1176. For stainless steel model, stainless steel bolts are appended.

<sup>(3)</sup> Choose screws whose dimension allow fixing thread depth into track rail  $\ell$  to be less than  $H_4$ .

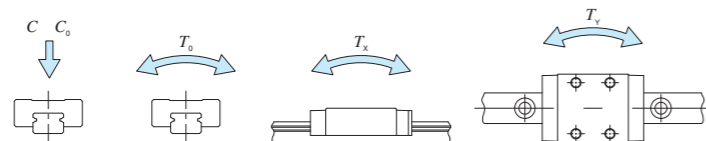
<sup>(4)</sup> The direction of basic dynamic load rating ( $C$ ), basic static load rating ( $C_0$ ), and static moment rating ( $T_0$ ,  $T_x$ ,  $T_y$ ) are shown in the sketches below.

The upper values of  $T_x$  and  $T_y$  are for one slide unit and the lower values are for two slide units in close contact.

If hybrid C-Lube Linear Way specification (supplemental code "/HB") is selected in ML series, see Table 10 on page II - 17.

Remarks 1. The specification of oil hole is shown in Table 13 on page II - 18.

2. The identification numbers with \* are our semi-standard items.



### Example of identification number of assembled set

Model code | Dimensions | Part code | Model code | Material code | Preload symbol | Classification symbol | Interchangeable code | Supplemental code

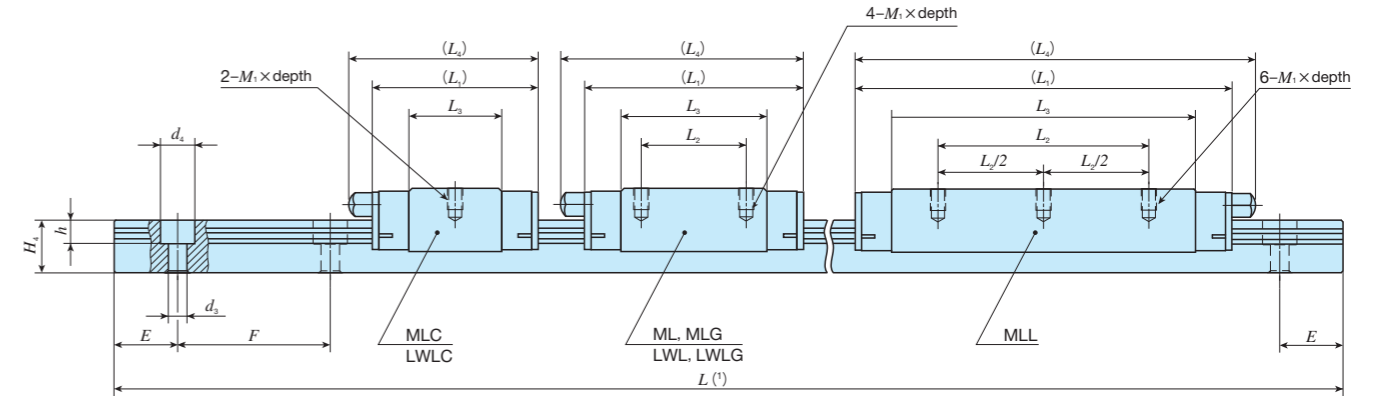
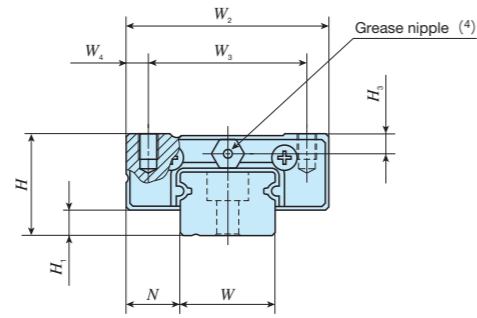
**ML** | **G** | **9** | **C2** | **R160** | - | - | - | - | /D

1 | 2 | 3 | 4 | 5 | 6 | 7 | 8 | 9 | 10

① Model	③ Size	⑦ Preload amount	⑨ Interchangeable
ML LWL··B LWL··N	9, 12	T <sub>0</sub> Clearance No symbol Standard T <sub>1</sub> Light preload	No symbol Non-interchangeable specification S1 S1 specification S2 S2 specification
② Length of slide unit	④ Number of slide unit (2)	⑧ Accuracy class	⑩ Special specification
C Short No symbol Standard G Long L Extra high rigidity long	-	H High P Precision	A, BS, D, E, HB, I, LR, MN N, Q, RE, S, U, W, Y
⑥ Material type	⑤ Length of track rail (160 mm)	-	-
No symbol Stainless steel made CS High carbon steel made	-	-	-

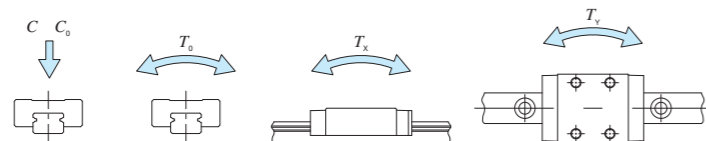
# IKO C-Lube Linear Way ML

Standard type											
Shape	ML • LWL										
Size	<table border="1"> <tr> <td>1</td> <td>2</td> <td>3</td> <td>5</td> <td>7</td> </tr> <tr> <td>9</td> <td>12</td> <td>15</td> <td>20</td> <td>25</td> </tr> </table>	1	2	3	5	7	9	12	15	20	25
1	2	3	5	7							
9	12	15	20	25							



Identification number	Interchangeable	Mass (Ref.) g		Dimensions of assembly mm							Dimensions of slide unit mm					Dimensions of track rail mm						Appended mounting bolt for track rail (2) mm	Basic dynamic load rating (3) C N	Basic static load rating (3) C0 N	Static moment rating (3)						
		Slide unit	Track rail (per 100 mm)	H	H1	N	W2	W3	W4	L1	L2	L3	L4	M1 x depth	H3	W	H4	d3	d4	h	E				F	Bolt size x l	T0 N · m	Tx N · m	Ty N · m		
MLC 15	○	43	107	16	4	8.5	32	25	3.5	32	—	17.8	37	M3x4	3.1	15	10	3.5	6.5	4.5	20	40	M3x10	3 490	3 890	30.0	11.7 84.5	9.8 70.9			
LWLC 15...B	○	42								42	20	27.8	47																		
ML 15	○	63								57	25	42.8	62																		
LWL 15...B	○	64								72	40	27.8	47																		
LWL 15...BCS	○	64								57	25	42.7	62																		
MLG 15	○	93								72	40	57.7	76																		
LWLG 15...B	○	95	—	—	—	—	—	—	—	—	—	—	—	—	—	—	—	—	—	—	—	—	—	—	—	—	—	—	—	—	—
MLL 15	○	122	156	20	5	10	40	30	5	38	—	22.3	43	M4x6	4.2	20	11	6	9.5	5.5	30	60	M5x14	4 580	5 300	54.0	19.4 134	16.3 112			
MLC 20	○	89								50	25	34.6	55																		
ML 20	○	130								68	30	52.3	73																		
LWL 20...B	○	133								54.5	—	31.9	64																		
LWL 20...BCS	○	133								78	35	55.7	88																		
MLG 20	○	189								98	40	75.5	108																		
LWLG 20...B	○	196	—	—	—	—	—	—	—	—	—	—	—	—	—	—	—	—	—	—	—	—	—	—	—	—	—	—	—	—	
MLC 25	○	189	243	25	5	12.5	48	35	6.5	54.5	—	31.9	64	M6x7	5	23	15	7	11.0	9.0	30	60	M6x16	9 120	10 600	128	57.4 376	48.1 316			
LWLC 25...B	○	190								78	35	55.7	88																		
ML 25	○	305								98	40	75.5	108																		
LWL 25...B	○	310								—	—	—	—																—	—	—
MLG 25	○	405	25 200	303	1 480	1 240	—	—	—	—	—	—	—	—	—	—	—	—	—	—	—	—	—	—	—	—	—	—	—	—	—
LWLG 25...B	○	413					—	—	—	—	—	—	—	—	—	—	—	—	—	—	—	—	—	—	—	—	—	—	—	—	—

- Notes (1) Track rail lengths  $L$  are shown in Table 3.1 on page II-10 and Table 3.3 on page II-12.  
 (2) The appended track rail mounting bolts are hexagon socket head bolts equivalent to JIS B 1176. For stainless steel model, stainless steel bolts are appended.  
 (3) The direction of basic dynamic load rating ( $C$ ), basic static load rating ( $C_0$ ), and static moment rating ( $T_0$ ,  $T_x$ ,  $T_y$ ) are shown in the sketches below. The upper values of  $T_x$  and  $T_y$  are for one slide unit and the lower values are for two slide units in close contact. If hybrid C-Lube Linear Way specification (supplemental code "/HB") is selected in MLC15, ML15, MLG15, and MLL15, see Table 10 on page II-17.  
 (4) The shapes of grease nipple vary by size. The specifications are shown in Table 14 on page II-18.

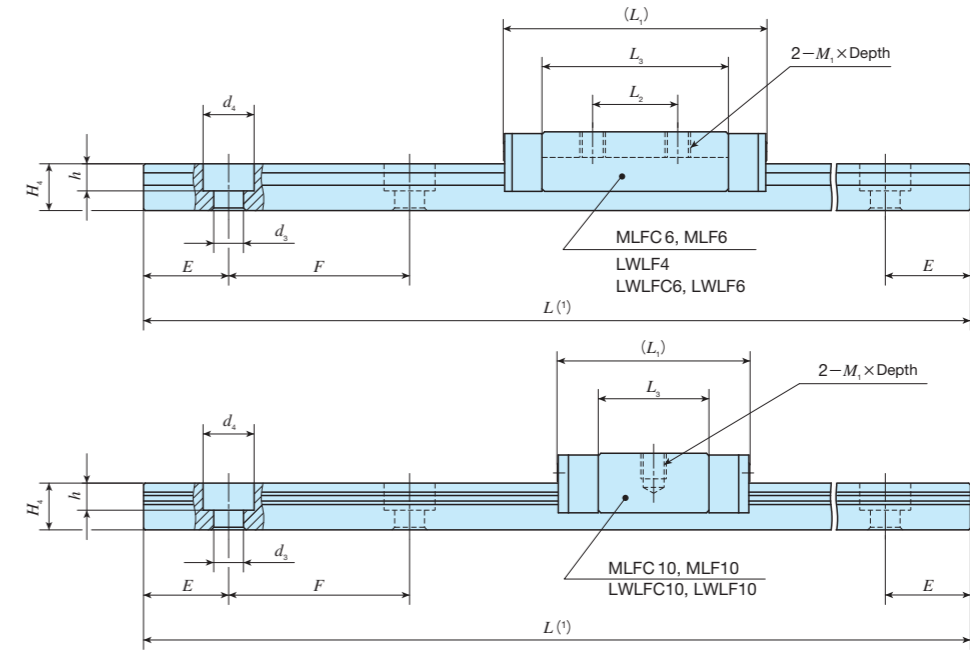
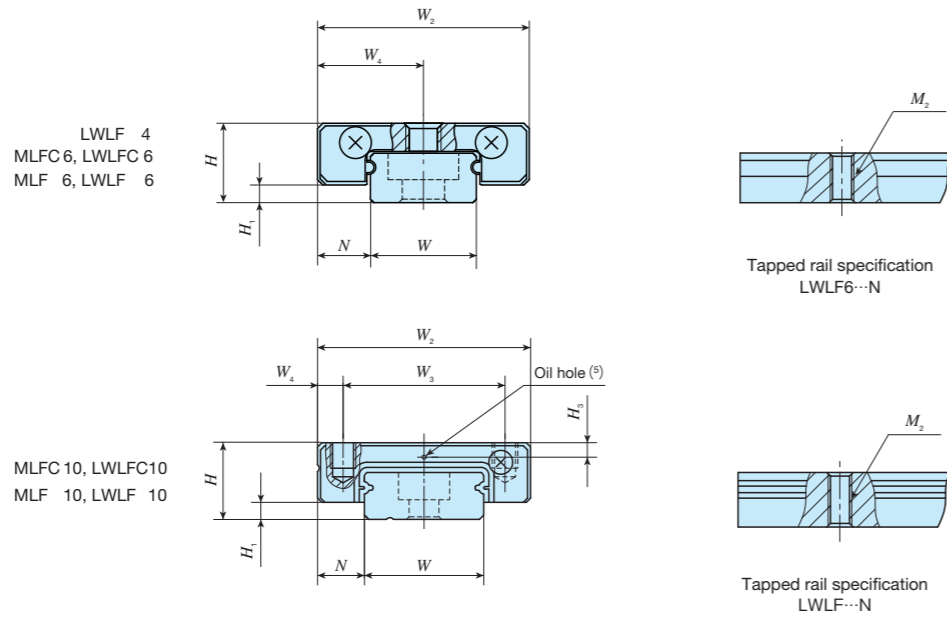


### Example of identification number of assembled set

Model code	Dimensions	Part code	Model code	Material code	Preload symbol	Classification symbol	Interchangeable code	Supplemental code
ML	G	15	C2	R320	T1	P	/D	
1	2	3	4	5	6	7	8	9

① Model ML LWL...B Standard type	③ Size 15, 20, 25	⑦ Preload amount T0 Clearance No symbol Standard T1 Light preload	⑨ Interchangeable No symbol Non-interchangeable specification S1 S1 specification S2 S2 specification
② Length of slide unit C Short No symbol Standard G Long L Extra high rigidity long	⑤ Length of track rail (320 mm)	⑧ Accuracy class H High P Precision	⑩ Special specification A, BS, D, E, HB, I, LR, MN N, O, RE, S, U, W, Y
⑥ Material type No symbol Stainless steel made CS High carbon steel made			

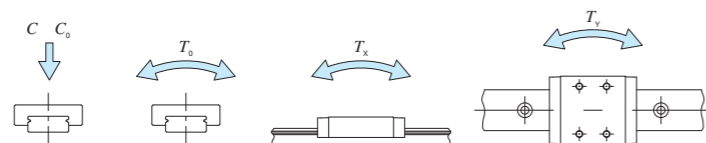
Wide type				
MLF • LWLF				
Shape				
Size	4	6	10	14
	18	24	30	42



Identification number		Interchangeable	Mass (Ref.) g		Dimensions of assembly mm			Dimensions of slide unit mm							Dimensions of track rail mm							Appended mounting bolt for track rail mm Bolt size $\times$ $\ell$	Basic dynamic load rating (4) C N	Basic static load rating (4) C <sub>0</sub> N	Static moment rating (4)																													
MLF series	LWLF series (No C-Lube)		Slide unit	Track rail (per 100 mm)	H	H <sub>1</sub>	N	W <sub>2</sub>	W <sub>3</sub>	W <sub>4</sub>	L <sub>1</sub>	L <sub>2</sub>	L <sub>3</sub>	M <sub>1</sub> $\times$ depth	H <sub>3</sub>	W	H <sub>4</sub>	M <sub>2</sub>	d <sub>3</sub>	d <sub>4</sub>	h				E	F	T <sub>0</sub> N · m	T <sub>x</sub> N · m	T <sub>y</sub> N · m																									
—	LWLF 4 <sup>(2)</sup>	—	2.1	6.8	4	1	3	10	—	5	17	6.5	11.9	M2 $\times$ 1.3	—	4	2.6	—	1.8	2.8	0.75	5	10	Cross-recessed pan head screw for precision equipment M1.6 $\times$ 5	390	677	1.4	1.3 7.1	1.5 8.4																									
MLFC 6 <sup>(2)</sup>	LWLF 6 <sup>(2)</sup>	—	2.1	13	4.5	1	3	12	—	6	15	4.5	9.8	M2 $\times$ 1.6	—	6	2.8	—	2.4	4	1.5	7.5	15	Cross-recessed pan head screw for precision equipment M2 $\times$ 4	334	542	1.7	0.84 5.1	1.0 6.1																									
MLFC 6...N <sup>(2)*</sup>	LWLF 6...N <sup>(2)*</sup>	—	2.4	12																				—						—	—	—	—	—	—	—	—	—	—	—	—	—	—	—	—	—	—	—	—	—	—	—	—	
MLF 6 <sup>(2)</sup>	LWLF 6 <sup>(2)</sup>	—	3.1	13																				—						—	—	—	—	—	—	—	—	—	—	—	—	—	—	—	—	—	Cross-recessed pan head screw for precision equipment M2 $\times$ 4	443	813	2.5	1.8 9.9	2.2 11.8		
MLF 6...N <sup>(2)*</sup>	LWLF 6...N <sup>(2)*</sup>	—	3.4	12																				—						—	—	—	—	—	—	—	—	—	—	—	—	—	—	—	—	—	—						—	—
MLFC 10	LWLF 10...B	○	6.1	28	6.5	1.5	3.5	17	13	2	20.5	—	13.6	M2.5 $\times$ 1.5	1.3	10	4	—	2.9	4.8	1.6	10	20	Cross-recessed pan head screw for precision equipment M2.5 $\times$ 7	712	1 180	6.1	2.6 14.9	2.2 12.5																									
MLFC 10...N*	LWLF 10...N*	—	6.1	29																				—						—	—	—	—	—	—	—	—	—	—	—	—	—	—	—	—	—	—	—	—	—	—	—	—	
MLF 10	LWLF 10...B	○	7.6	28																				—						—	—	—	—	—	—	—	—	—	—	—	—	—	—	—	—	—	—	—	—	—	—	—	—	—
MLF 10...N*	LWLF 10...N*	—	7.5	29																				—						—	—	—	—	—	—	—	—	—	—	—	—	—	—	—	—	—	—	Cross-recessed pan head screw for precision equipment M2.5 $\times$ 7	849	1 510	7.8	4.2 22.4	3.5 18.8	
MLF 10...N*	LWLF 10...N*	—	7.5	29	—	—	—	—	—	—	—	—	—	—	—	—	—	—	—	—	—	—	—	—	—	—	—	—	—																									

Notes (1) Track rail lengths  $L$  are shown in Table 3.2 on page II - 11.  
 (2) Size 4 and 6 are non-retained-ball type. No end seal is attached.  
 (3) Choose screws whose dimension allow fixing thread depth into track rail  $\ell$  to be less than  $H_4$ .  
 (4) The direction of basic dynamic load rating ( $C$ ), basic static load rating ( $C_0$ ), and static moment rating ( $T_0$ ,  $T_x$ ,  $T_y$ ) are shown in the sketches below.  
 The upper values of  $T_x$  and  $T_y$  are for one slide unit and the lower values are for two slide units in close contact.  
 (5) No oil hole is prepared for size 4 and 6.  
 The specification of oil hole for size 10 is shown in Table 13 on page II - 18.

Remark: The identification numbers with \* are our semi-standard items.

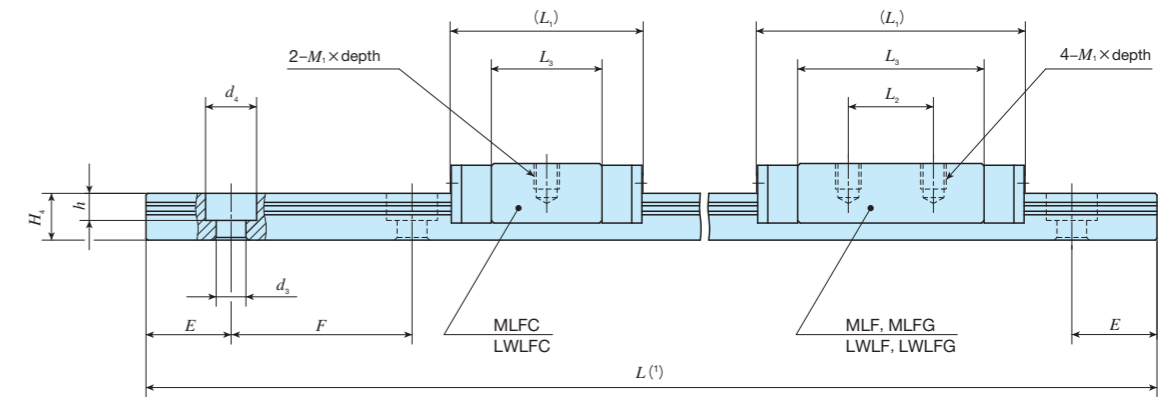
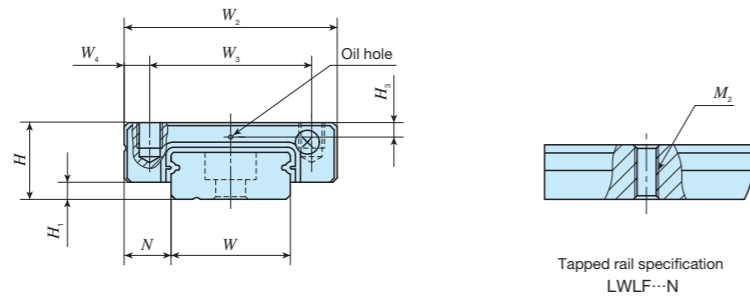


### Example of identification number of assembled set

Model code	Dimensions	Part code	Model code	Preload symbol	Classification symbol	Interchangeable code	Supplemental code	
MLF	C	10	C2	R120	T <sub>0</sub>	P	/D	
①	②	③	④	⑤	⑥	⑦	⑧	
① Model MLF LWLF(...B) LWLF...N Wide type	② Length of slide unit C No symbol Short Standard	③ Size 4, 6, 10	④ Number of slide unit (2)	⑤ Length of track rail (120 mm)	⑥ Preload amount T <sub>0</sub> Clearance No symbol Standard	⑦ Accuracy class H High P Precision	⑧ Interchangeable No symbol Non-interchangeable specification S1 S1 specification S2 S2 specification	⑨ Special specification A, BS, D, E, I, MN, N, Q RE, S, W, Y

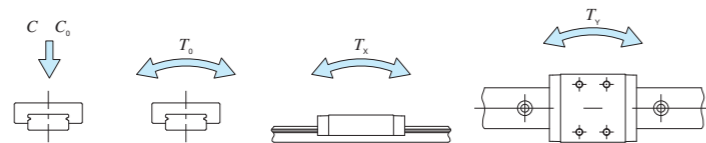
# IKO C-Lube Linear Way ML

Wide type				
MLF • LWLF				
Shape				
Size	4	6	10	14
	18	24	30	42



Identification number	Interchangeable	Mass (Ref.) g		Dimensions of assembly mm			Dimensions of slide unit mm							Dimensions of track rail mm							Appended mounting bolt for track rail (2) mm	Basic dynamic load rating (4) C N	Basic static load rating (4) C0 N	Static moment rating (4)										
		Slide unit	Track rail (per 100 mm)	H	H1	N	W2	W3	W4	L1	L2	L3	M1 × depth	H3	W	H4	M2	d3	d4	h				E	F	T0 N · m	Tx N · m	Ty N · m						
MLFC 14	LWLF 14...B	○	13	54	9	2	5.5	25	19	3	22.5	-	13	M3×3	1.7	14	5.5	-	3.5	6	3.2	15	30	M3×8	1 240	1 700	12.2	3.8 24.6	3.2 20.7					
MLFC 14...N*	LWLF 14...N*	-		56																										M4 Through	-	-	-	M4 × ℓ (3) (Not appended)
MLF 14	LWLF 14...B	○	20	54																										31.5	10	22	-	3.5
MLF 14...N*	LWLF 14...N*	-	20	56							31.5	10	22					-	3.5	6	3.2			M4 × ℓ (3) (Not appended)										
MLFG 14	LWLF 14...B	○	21	54							42	19	32.5					-	3.5	6	3.2			M3×8	2 320	4 160	29.8	21.0 104	17.6 87.6					
MLFG 14...N*	LWLF 14...N*	-	21	56																										M4 Through	-	-	-	M4 × ℓ (3) (Not appended)
MLFG 14...N*	LWLF 14...N*	-	29	54																										M4 Through	-	-	-	M4 × ℓ (3) (Not appended)
MLFG 14...N*	LWLF 14...N*	-	29	56																										M4 Through	-	-	-	M4 × ℓ (3) (Not appended)
MLFG 14...N*	LWLF 14...N*	-	31	54																										M4 Through	-	-	-	M4 × ℓ (3) (Not appended)
MLFG 14...N*	LWLF 14...N*	-	31	56																										M4 Through	-	-	-	M4 × ℓ (3) (Not appended)

Notes (1) Track rail lengths  $L$  are shown in Table 3.2 on page II - 11.  
 (2) The appended track rail mounting bolts are hexagon socket head bolts equivalent to JIS B 1176.  
 (3) Choose screws whose dimension allow fixing thread depth into track rail  $\ell$  to be less than  $H_4$ .  
 (4) The direction of basic dynamic load rating ( $C$ ), basic static load rating ( $C_0$ ), and static moment rating ( $T_0$ ,  $T_x$ ,  $T_y$ ) are shown in the sketches below.  
 The upper values of  $T_x$  and  $T_y$  are for one slide unit and the lower values are for two slide units in close contact.  
 Remarks 1. The specification of oil hole is shown in Table 13 on page II - 18.  
 2. The identification numbers with \* are our semi-standard items.



## Example of identification number of assembled set

Model code	Dimensions	Part code	Model code	Preload symbol	Classification symbol	Interchangeable code	Supplemental code
MLF	G	14	C2	R240	T1	P	/D
1	2	3	4	5	6	7	8

① Model	Wide type
MLF	
LWLF...B	
LWLF...N	

② Length of slide unit	Long
C	
No symbol	
G	

③ Size	14
--------	----

④ Number of slide unit (2)

⑤ Length of track rail (240 mm)

⑥ Preload amount	Light preload
T0	Clearance
No symbol	Standard
T1	Light preload

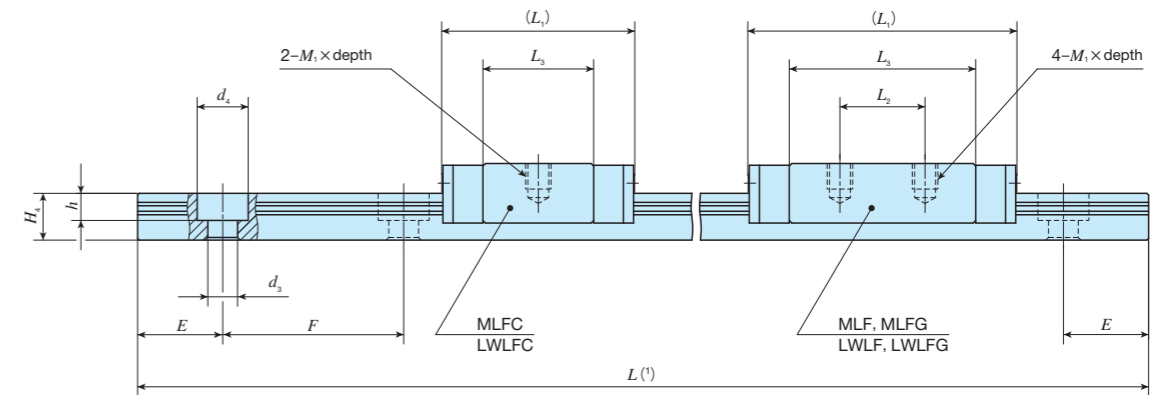
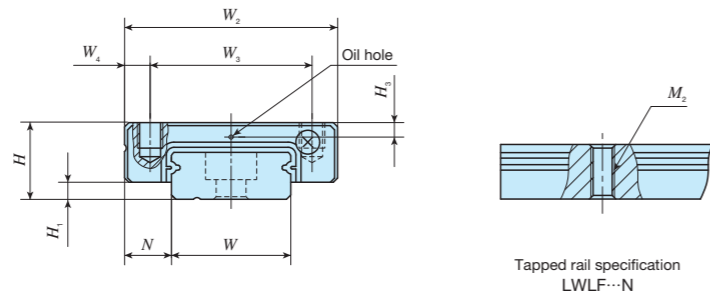
⑦ Accuracy class	Precision
H	
No symbol	
P	

⑧ Interchangeable	S2 specification
No symbol	Non-interchangeable specification
S1	S1 specification
S2	S2 specification

⑨ Special specification	N, Q, RE, S, W, Y
A, BS, D, E, I, LR, MN	

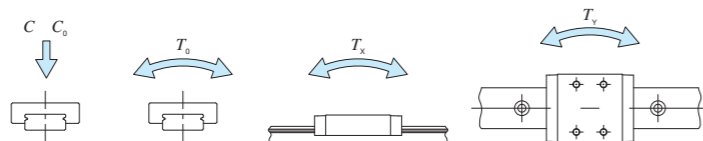


Wide type									
MLF • LWF									
Shape									
Size	<table border="1"> <tr> <td>4</td> <td>6</td> <td>10</td> <td>14</td> </tr> <tr> <td>18</td> <td>24</td> <td>30</td> <td>42</td> </tr> </table>	4	6	10	14	18	24	30	42
4	6	10	14						
18	24	30	42						



Identification number	Interchangeable	Mass (Ref.) g		Dimensions of assembly mm			Dimensions of slide unit mm							Dimensions of track rail mm							Appended mounting bolt for track rail (2) mm	Basic dynamic load rating (4) C N	Basic static load rating (4) C <sub>0</sub> N	Static moment rating (4) N·m																														
		Slide unit	Track rail (per 100 mm)	H	H <sub>1</sub>	N	W <sub>2</sub>	W <sub>3</sub>	W <sub>4</sub>	L <sub>1</sub>	L <sub>2</sub>	L <sub>3</sub>	M <sub>1</sub> × depth	H <sub>3</sub>	W	H <sub>4</sub>	M <sub>2</sub>	d <sub>3</sub>	d <sub>4</sub>	h				E	F	T <sub>0</sub>	T <sub>x</sub>	T <sub>y</sub>																										
MLFC 18	LWLF 18...B	○	90	12	3	6	30	21	4.5	38.5	12	28.6	M3×3	2.5	18	7	-	3.5	6.5	4.5	15	30	M3×8	1 510	2 120	19.4	5.5 35.9	4.7 30.1																										
MLFC 18...N*	LWLF 18...N*	-	92																										26.5	-	16.6	M4 Through	M4 × ℓ (3) (Not appended)																					
MLF 18	LWLF 18...B	○	90																										23	3.5	50.5	24	40.4	-	3.5	6.5	4.5	M3×8	2 280	3 810	34.9	16.9 88.8	14.2 74.5											
-	LWLF 18...BCS	○	44																										23	3.5	50.5	24	40.4	M4 Through	-	-	-	M4 × ℓ (3) (Not appended)																
MLF 18...N*	LWLF 18...N*	-	42																										23	3.5	50.5	24	40.4	M4 Through	-	-	-	M4 × ℓ (3) (Not appended)																
MLFG 18	LWLF 18...B	○	59																										23	3.5	50.5	24	40.4	-	3.5	6.5	4.5	M3×8	2 870	5 300	48.5	31.9 159	26.7 134											
MLFG 18...N*	LWLF 18...N*	-	59																										23	3.5	50.5	24	40.4	M4 Through	-	-	-	M4 × ℓ (3) (Not appended)																
MLFG 18...N*	LWLF 18...N*	-	61																										23	3.5	50.5	24	40.4	M4 Through	-	-	-	M4 × ℓ (3) (Not appended)																
MLFC 24	LWLF 24...B	○	46																										139	14	3	8	40	28	6	44	15	31	M3×3.5	3.2	24	8	-	4.5	8	4.5	20	40	M4×10	4 310	6 200	75.6	30.6 168	25.7 141
MLFC 24	LWLF 24...B	○	45																																																			
MLF 24	LWLF 24...B	○	74	30.5	-	17.7	M3×3.5	4 310	6 200	75.6	30.6 168	25.7 141																																										
-	LWLF 24...BCS	○	76	30.5	-	17.7	M3×3.5	4 310	6 200	75.6	30.6 168	25.7 141																																										
MLFG 24	LWLF 24...B	○	108	59	28	46.3	M3×3.5	5 620	9 060	111	63.3 321	53.1 270																																										
MLFG 24	LWLF 24...B	○	111	59	28	46.3	M3×3.5	5 620	9 060	111	63.3 321	53.1 270																																										

Notes (1) Track rail lengths *L* are shown in Table 3.2 on page II - 11 and Table 3.3 on page II - 12.  
 (2) The appended track rail mounting bolts are hexagon socket head bolts equivalent to JIS B 1176. For stainless steel model, stainless steel bolts are appended.  
 (3) Choose screws whose dimension allow fixing thread depth into track rail ℓ to be less than *H*<sub>4</sub>.  
 (4) The direction of basic dynamic load rating (*C*), basic static load rating (*C*<sub>0</sub>), and static moment rating (*T*<sub>0</sub>, *T*<sub>x</sub>, *T*<sub>y</sub>) are shown in the sketches below.  
 The upper values of *T*<sub>x</sub> and *T*<sub>y</sub> are for one slide unit and the lower values are for two slide units in close contact.  
 Remarks 1. The specification of oil hole is shown in Table 13 on page II - 18.  
 2. The identification numbers with \* are our semi-standard items.



### Example of identification number of assembled set

Model code	Dimensions	Part code	Model code	Material code	Preload symbol	Classification symbol	Interchangeable code	Supplemental code
MLF	G	18	C2	R300	T <sub>1</sub>	P	-	/D
①	②	③	④	⑤	⑥	⑦	⑧	⑨

① Model	MLF LWLF...B LWLF...N	Wide type
---------	-----------------------------	-----------

③ Size	18, 24
--------	--------

⑦ Preload amount	T <sub>0</sub> Clearance No symbol Standard T <sub>1</sub> Light preload
------------------	--

⑨ Interchangeable	No symbol Non-interchangeable specification S1 S1 specification S2 S2 specification
-------------------	---

② Length of slide unit	C Short No symbol Standard G Long
------------------------	---

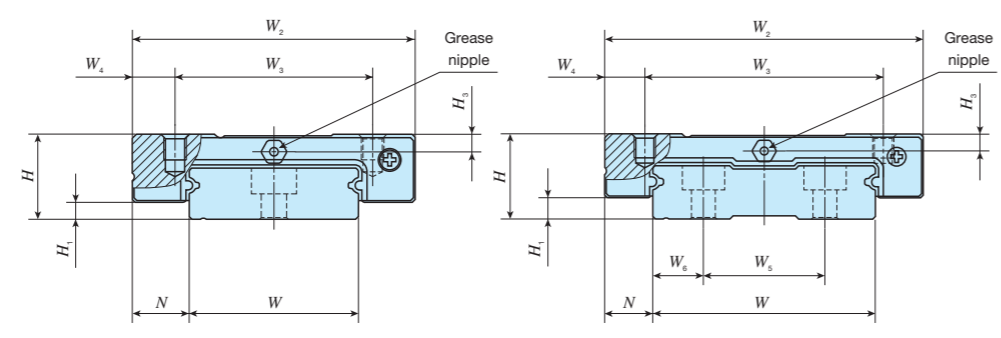
④ Number of slide unit (2)	
⑤ Length of track rail (300 mm)	
⑥ Material type	No symbol Stainless steel made CS High carbon steel made

⑧ Accuracy class	H High P Precision
------------------	-----------------------

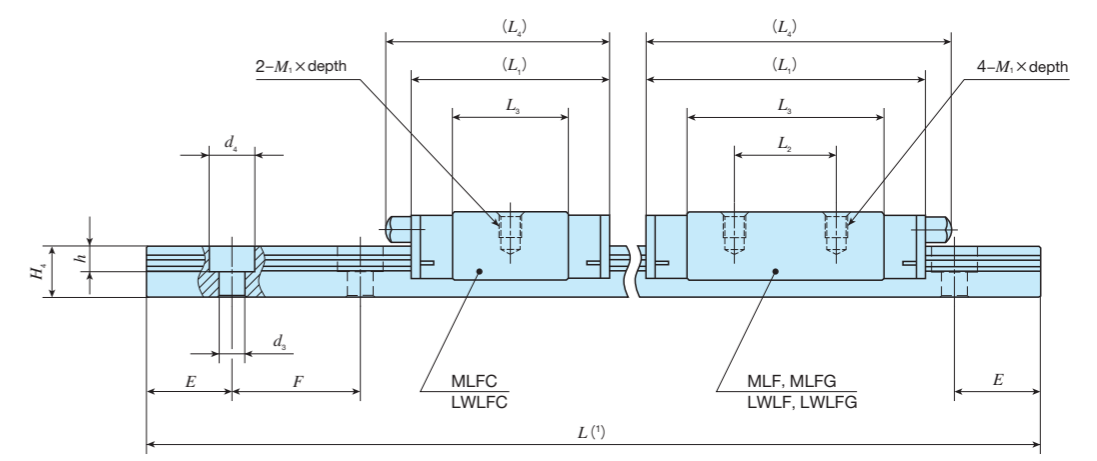
⑩ Special specification	A, BS, D, E, I, LR, MN N, Q, RE, S, U, W, Y
-------------------------	--

# IKO C-Lube Linear Way ML

Wide type				
Shape	MLF • LWLF			
Size	4	6	10	14
	18	24	30	42

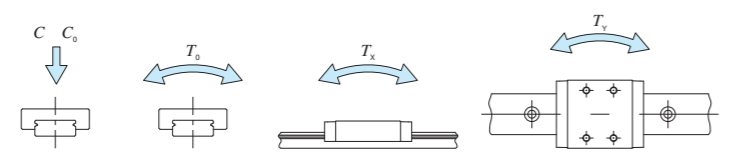


MLFC 42, LWLFC 42  
MLF 42, LWLF 42  
MLFG 42, LWLFG 42



Identification number	Interchangeable	Mass (Ref.) g		Dimensions of assembly mm			Dimensions of slide unit mm							Dimensions of track rail mm						Appended mounting bolt for track rail mm Bolt size × ℓ	Basic dynamic load rating <sup>(2)</sup> C N	Basic static load rating <sup>(2)</sup> C <sub>0</sub> N	Static moment rating <sup>(3)</sup>								
		Slide unit	Track rail (per 100 mm)	H	H <sub>1</sub>	N	W <sub>2</sub>	W <sub>3</sub>	W <sub>4</sub>	L <sub>1</sub>	L <sub>2</sub>	L <sub>3</sub>	L <sub>4</sub>	M <sub>1</sub> × depth	H <sub>3</sub>	W	H <sub>4</sub>	W <sub>5</sub>	W <sub>6</sub>				d <sub>3</sub>	d <sub>4</sub>	h	E	F	T <sub>0</sub> N · m	T <sub>x</sub> N · m	T <sub>y</sub> N · m	
MLFC 30	LWLFC 30...B	○	70	198	15	3	10	50	35	7.5	35.5	—	20.5	40	M4×4.5	3.1	30	9	—	—	4.5	8	4.5	20	40	M4×12	3 890	4 540	69.1	15.4	13.0
MLF 30	LWLF 30...B	○	111								49.5	18	34.8	54															128	48.7	40.8
—	LWLF 30...BCS	○	112								68.5	35	53.8	73															187	100	84.3
MLFG 30	LWLFG 30...B	○	167								—	—	—	—															128	24.8	20.8
—	LWLFG 30...B	○	170								—	—	—	—															187	508	426
MLFC 42	LWLFC 42...B	○	95	294	16	4	9	60	45	7.5	41.5	—	25.7	46	M4×4.5	3.2	42	10	23	9.5	4.5	8	4.5	20	40	M4×12	5 440	6 810	144	30.8	25.8
—	LWLF 42...B	○	138								55	20	39.4	60															209	61.3	51.4
—	LWLF 42...BCS	○	140								74.5	35	58.7	79															209	333	280
MLFG 42	LWLFG 42...B	○	200								—	—	—	—															321	140	117
—	LWLFG 42...B	○	204								—	—	—	—															305	644	541

Notes (1) Track rail lengths *L* are shown in Table 3.2 on page II - 11 and Table 3.3 on page II - 12.  
 (2) The appended track rail mounting bolts are hexagon socket head bolts equivalent to JIS B 1176. For stainless steel model, stainless steel bolts are appended.  
 (3) The direction of basic dynamic load rating (*C*), basic static load rating (*C<sub>0</sub>*), and static moment rating (*T<sub>0</sub>*, *T<sub>x</sub>*, *T<sub>y</sub>*) are shown in the sketches below.  
 The upper values of *T<sub>x</sub>* and *T<sub>y</sub>* are for one slide unit and the lower values are for two slide units in close contact.  
 Remark: The specifications of grease nipple are shown in Table 14 on page II - 18.



**Example of identification number of assembled set**

Model code: MLF, Dimensions: G, Part code: 42, Model code: C2, Material code: R320, Preload symbol: T1, Classification symbol: P, Interchangeable code: /D

① Model: MLF, LWLF...B Wide type

② Length of slide unit: C Short, No symbol Standard, G Long

③ Size: 30, 42

④ Number of slide unit (2)

⑤ Length of track rail (320 mm)

⑥ Material type: No symbol Stainless steel made, CS High carbon steel made

⑦ Preload amount: T<sub>0</sub> Clearance, No symbol Standard, T<sub>1</sub> Light preload

⑧ Accuracy class: H High, P Precision

⑨ Interchangeable: No symbol Non-interchangeable specification, S1 S1 specification, S2 S2 specification

⑩ Special specification: A, BS, D, E, I, LR, MN, N, Q, RE, S, U, W, Y