

Crossed Roller Way

Anti-Creep Cage Crossed Roller Way

Anti-Creep Cage Crossed Roller Way H

Crossed Roller Way

Anti-Creep Cage Crossed Roller Way Unit

Crossed Roller Way Unit

CRW(G)(...H)
CRWU(G)

A wide variety of series products including mechanism are available! **Features of**

IKO Crossed Roller Way is a linear motion rolling guide incorporating a roller cage between two ways whose two V-shaped surfaces are used as track groove. Arrangement of cylindrical rollers by orthogonalizing them alternately allows receiving of loads in any direction and executes extremely high-accuracy and smooth linear motion.

Crossed Roller Way **CRW·CRWM**



Crossed Roller Way Unit **CRWU**



Anti-Creep Cage Crossed Roller Way **CRWG**

IKO Anti-Creep Cage Crossed Roller Way CRWG is a product with a cage creep **IKO** proof function using a rack and pinion mechanism originated from the Crossed Roller Way CRW featuring smooth linear motion with super high accuracy. CRWG ... H is high load capacity type of CRWG, which has achieved greatly increased load rating by redesigning of raceway of CRWG.

Anti-Creep Cage Crossed Roller Way H **CRWG...H**

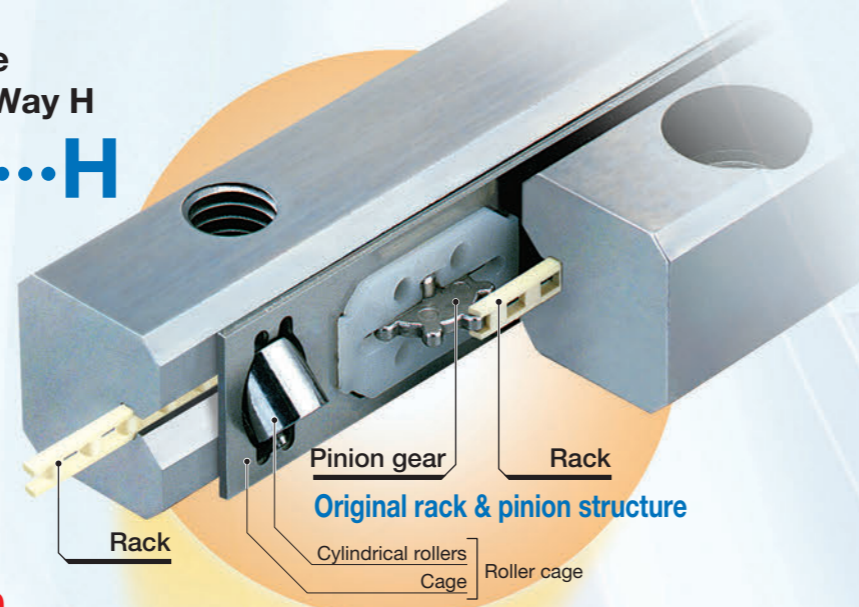

**Built-in rack & pinion type
Solves cage creep issue!!**

Anti-Creep Cage Crossed Roller Way Unit **CRWUG**

IKO Anti-Creep Cage Crossed Roller Way Unit CRWUG is a product with a cage creep proof function-provided Crossed Roller Way CRWG mounted into a ground-finished rigid table and bed.

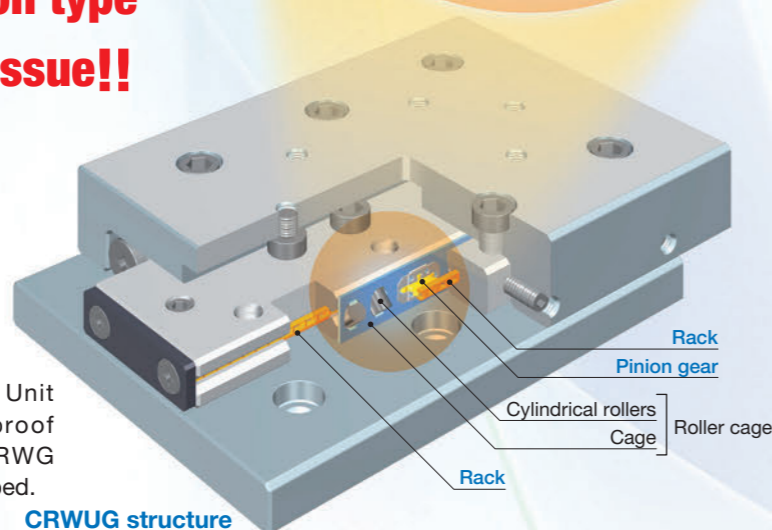

CRWUG structure

cage misalignment prevention **Crossed Roller Way**

Features of Built-in Rack & Pinion Type

Solves Cage Creep Issue!

Perfect solution for cage creep issues by a built-in rack and pinion mechanism as an original design.

■ Freedom in Mounting

This series is reliable for applications such as vertical axis where Crossed Roller Way may have chances of cage creep.

■ High-Speed and High-Tact Operation

Any corrective operation for cage creep is not necessary even for high velocity operation.

■ Saving Energy

No remedy motion of cage is necessary even in long term operation.

No cage creep even under high-tact operation in vertical axis!

Test conditions		
Model number	CRWG3	
Test method	Vibration test machine	
Condition	Posture	Vertical
	Maximum velocity	827 mm/s
	Acceleration	15 G
	Number of cycle	31 Hz
	Stroke length	8 mm
Mass of moving part	330 g	
Total cycles	100,000,000 cycles	

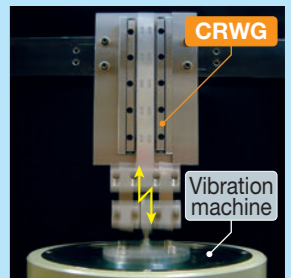

(Result) No cage creep nor material damage in any component is found.

Interchangeable in Mounting Dimensions!

Adoption of original structure of arranging a rack inside the way keeps the same mounting dimensions as conventional Crossed Roller Way CRW.

* The mounting dimensions of CRWG1 ... H and CRW1 are different.

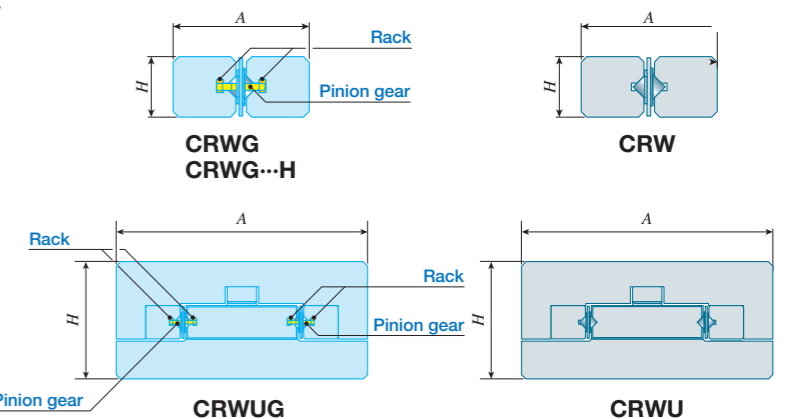

■ Easy Replacement

Since they have the same external dimensions to those of the existing Crossed Roller Way and Crossed Roller Way Unit, existing Crossed Roller Way and Crossed Roller Way Unit can be replaced without any mounting dimensions modification.

Smooth and Extremely-High Accurate Operation!

Combination of precisely finished raceways and non-recirculating type linear motion rolling guide with super high precision rollers provides superbly smooth motion with very high accuracy.

■ Improved Running Accuracy

Extremely high running accuracy can be achieved without run deflection by recirculating type linear motion rolling guide.

■ Suitable for Micro-Feeding

Improvement of precision positioning accuracy and superior corresponding feature to micro-feeding command can be expected because of the linear motion without stick-slip by extremely small frictional resistance.

Anti-Creep Cage
Crossed Roller Way

CRWG

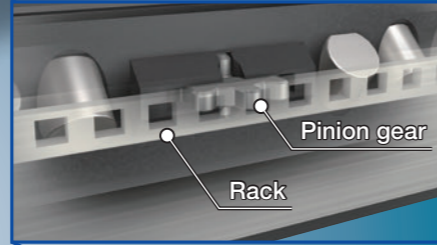
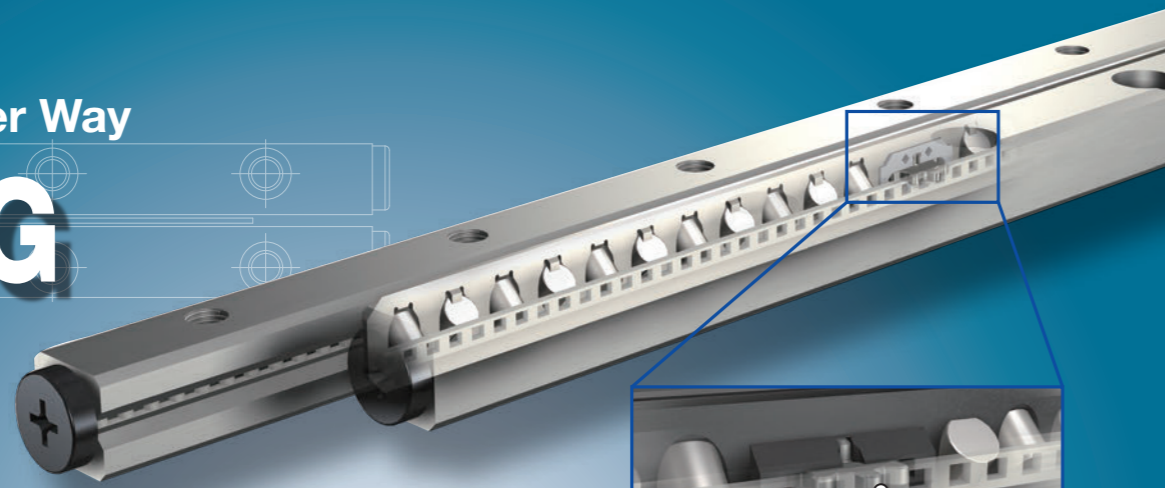

Anti-Creep Cage
Crossed Roller Way H

CRWG...H

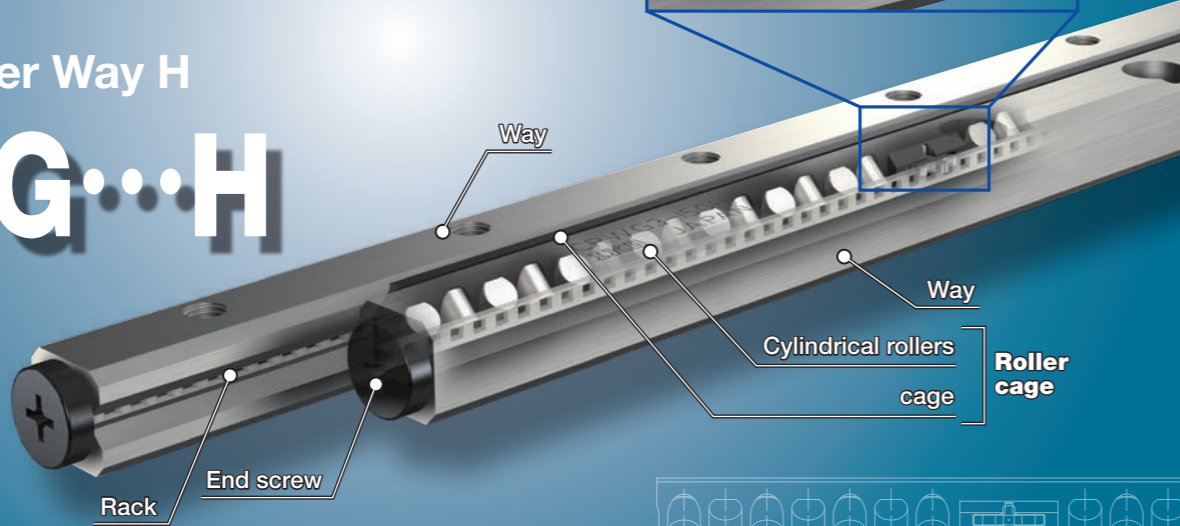

Crossed Roller Way
CRW/CRWM

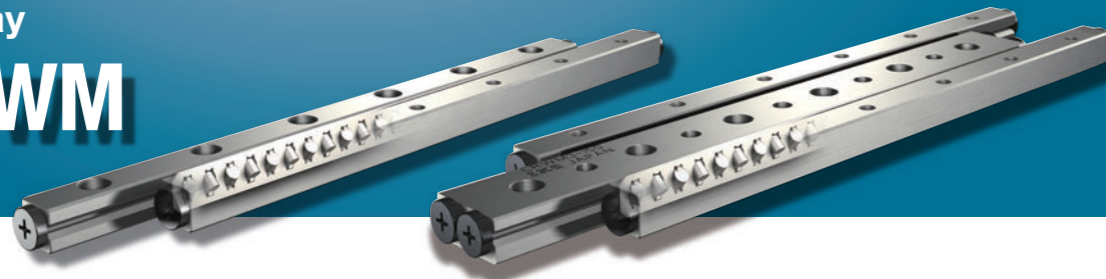

Points

1 Superior load balance

This unit has a roller cage with cylindrical rollers alternately orthogonalized between two ways whose two V-shaped surfaces are used as track groove, which allows receiving of loads in any direction.

2 Solves cage creep problem

CRWG and CRWG...H units, which have originally-designed rack and pinion mechanism built-in, solve the cage creep issue and support high-speed & high-tact operation and vertical axis application.

3 High load capacity type CRWG...H

CRWG...H has achieved greatly increased load rating by redesigning of raceway of CRWG, thereby downsizing the machine and equipment and prolonging their lifetime.

4 Standard type and module type

There are two types in the CRW: one is standard type of using four ways and two roller cages in combination as a set and the other is module type of integrating two internal ways in a single structure.

5 Easy mounting

The mounting holes of the way are provided with boring and female thread, so that the mounting structure is not restricted. The module type with two internal ways integrated in a single structure is simple in mounting structure, thus producing high accuracy linear motion.

6 Stainless steels superior in corrosion resistance are listed on lineup.

Products made of stainless steel are highly resistance to corrosion, so that they are suitable for applications where rust prevention oil is not preferred, such as in a cleanroom environment.

Identification Number and Specification

Example of an identification number

The specifications of CRWG series, CRWG...H series, and CRW series are indicated by the identification number. Indicate the identification number, consisting of a model code, a dimension, a part code, a material code, a classification symbol, and any supplemental codes for each specification to apply.

	1	2	3	1	4	5	6	7
CRWG series	CRWG	3	- 150	H			SP	/B
CRWG...H series								
CRW series	CRW	3	- 150		C20	SL	SP	/U
Standard type								
	CRW	3	- 250×300		C36	SL	SP	/U
Module type								
	CRWM	3	- 150		C20		SP	/U
	CRWM	3	- 250×150		C20		SP	/U

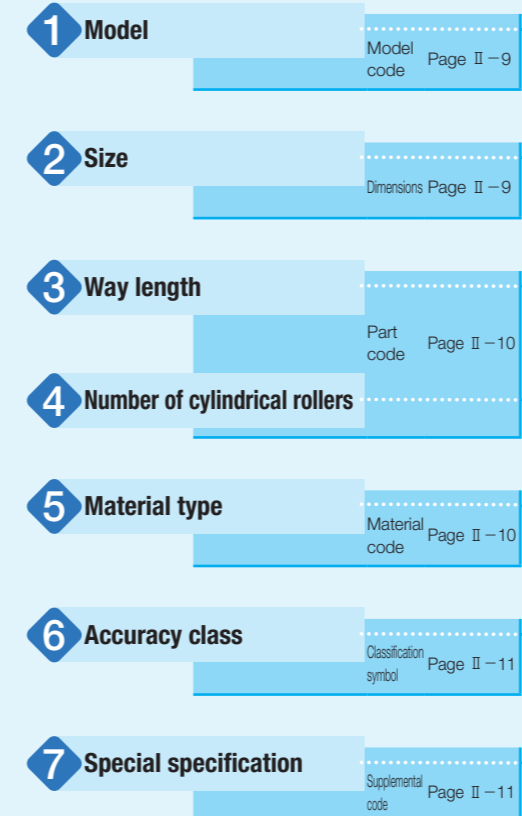

Note: One set of the CRW, CRWG, and CRWG...H series consists of a combination of four ways and two roller cages.

CRW(G)...H
CRW(G)

Identification Number and Specification — Model · Size —

1 Model	Anti-Creep Cage Crossed Roller Way (CRWG series)	: CRWG
	Anti-Creep Cage Crossed Roller Way H (CRWG...H series)	: CRWG...H
	Crossed Roller Way (CRW series)	Standard type : CRW Module type : CRWM
	For applicable models and sizes, see Fig. 1.	

2 Size	1, 2, 3, 4, 6, 9, 12, 15, 18, 24	For applicable models and sizes, see Table 1.
---------------	----------------------------------	---

Table 1 Models and Sizes of CRWG series, CRWG...H series, and CRW series

Series	Shape	Material	Model	Size										
				1	2	3	4	6	9	12	15	18	24	
CRWG		High carbon steel made	CRWG	-	○	○	○	○	-	-	-	-	-	-
CRWG...H		High carbon steel made	CRWG...H	○	○	○	○	-	-	-	-	-	-	-
CRW	Standard type 	High carbon steel made	CRW	○	○	○	○	○	○	○	○	○	○	○
		Stainless steel made	CRW...SL	○	○	○	○	○	-	-	-	-	-	-
	Module type 	High carbon steel made	CRWM	○	○	○	○	-	-	-	-	-	-	-

— Way length · Number of Cylindrical Rollers · Material Type —

3 Way length	○ ○×○	The way length is indicated in mm. The CRW series can be combined with a way of different length. For details of way length, see the dimension tables on pages II-27 to II-52.
---------------------	----------	--

Specifying the combination of different way lengths

Combination of standard type

This combination consists of two short ways, two long ways, and two roller cages, as a set.

In this case, make sure to specify the number of rollers to be incorporated in the roller cages. (For calculation of incorporated rollers, see the Selection of CRW Series on page II-17.)

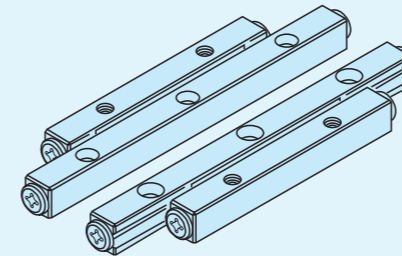
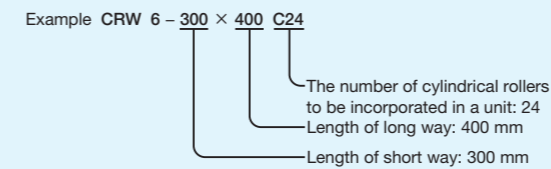

Combination of module type

This combination consists of one long center way, two short ways, and two roller cages, as a set.

In this case, make sure to specify the number of rollers to be incorporated in the roller cages. (For calculation of incorporated rollers, see the Selection of CRW Series on page II-17.)

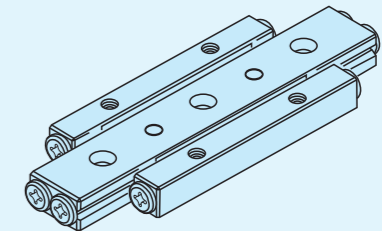
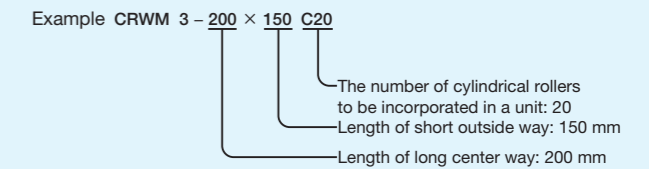

4 Number of cylindrical rollers	: No symbol	This represents the number of cylindrical rollers incorporated into a CRW series cage. If not directed, the number of cylindrical rollers indicated in the dimension table shall be incorporated in a roller cage.
	: C○	

5 Material type	High carbon steel made	: No symbol	For applicable models and sizes, see Fig. 1.
	Stainless steel made	: SL	

CRW(G)(...H)
CRW(G)

6 Accuracy class	Standard	: No symbol	For parallelism of the raceway to reference mounting surface and the tolerance of the parallelism of two raceways of CRWM, see Fig. 1.
	Super precision	: SP	

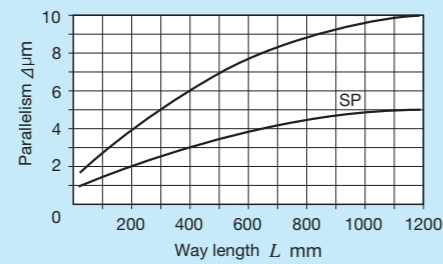
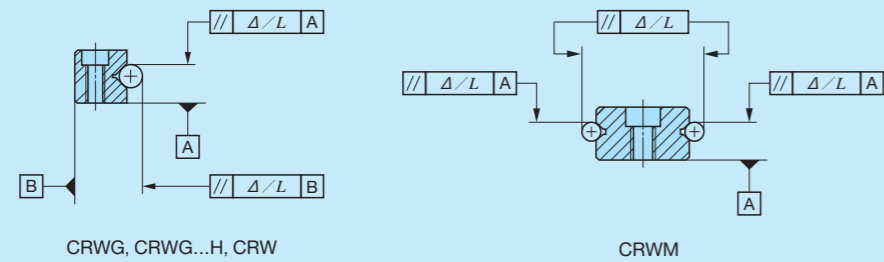

Fig. 1 Accuracy

7 Special specification	B, M, SA, SB, U	For applicable special specifications, see Table 2. For combination of multiple special specifications, see Table 3. For details of special specifications, see pages II-11 to II-14.
--------------------------------	-----------------	---

Table 2 Application of special specifications

Special specification	Supplemental code	Size									
		1	2	3	4	6	9	12	15	18	24
Special mounting screw	/B	—	—	○	○	○	○	○	○	○	○
High rigidity roller cage ⁽¹⁾ ⁽²⁾	/M	—	—	—	—	○	○	○	○	○	○
End stopper SA ⁽²⁾	/SA	—	○	○	○	○	○	○	○	○	○
End stopper SB ⁽²⁾	/SB	—	○	○	○	○	○	○	○	○	○
Wiper seal ⁽²⁾	/U	—	○	○	○	○	○	○	○	○	○

Notes ⁽¹⁾ Not applicable to module type.
⁽²⁾ Not applicable to CRWG series and CRWG...H series.

Table 3 Combination of special specifications

M	○			
SA	○	○		
SB	○	○	—	
U	○	○	—	—
	B	M	SA	SB

Remarks 1. The combination of "—" shown in the table is not available.
2. When using multiple types for combination, please indicate by arranging the symbols in alphabetical order.

Special mounting screw /B

Preload adjusting-side way can be moved by adjusting the preload. Allowance for movement is required between a way fixing screw and mounting hole, but special mounting screws are provided for the cases where enough allowance is not provided or a fixing screw should be mounted from the way side as shown in Fig. 2. This special mounting screw can also be used for the case where the mounting hole for mounting the fixed-side way and positioning accuracy of female thread are not enough. This special mounting screw is high carbon steel-made only.

Table 4 Dimensions of special mounting screw

Size	Bolt size	d	D	H	L	S
3	M 3	2.3	5	3	12	5
4	M 4	3.1	6	4	15	6
6	M 5	3.9	8	5	20	8
9	M 6	4.6	8.5	6	30	12
12	M 8	6.2	11.5	8	40	17
15	M10	7.9	14	10	45	16
18	M12	9.6	16	12	50	19
24	M14	11.2	19.5	14	70	26

unit: mm

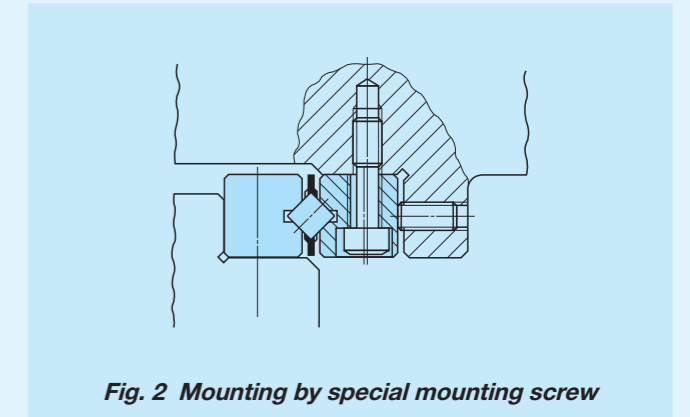
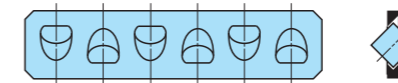

Fig. 2 Mounting by special mounting screw

High rigidity roller cage /M



The cage is changed into a high rigidity copper alloy-made cage designed to suit vertical axis application. This cage has a structure to prevent a roller from dropping off in one-side direction. For using a high rigidity roller cage for vertical axis application, it is recommended to use the cage in combination with end stopper SB.

End stopper SA /SA

When the stroke frequency is high and cage creep may be caused by the vibration and non-uniformly varying load, the end screw is changed into end stopper SA.
For the series of size 1, an end stopper SA according to end stopper SA is included as standard.

Table 5 Dimensions of end stopper SA

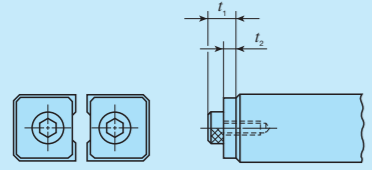

unit: mm

Size	t_1	t_2
2	4.5	2
3	5	2
4	7	3
6	8	3
9	10	4

Size	t_1	t_2
12	11	5
15	14	6
18	14	6
24	16	6

End stopper SB /SB

When using a high rigidity roller cage for vertical axis application, the end screw is changed into end stopper SB to regulate the cage stroke at the end.
The end stopper SB cannot be mounted on all way ends. Standard mounting positions are shown in Fig. 3. The mounting positions can be changed by loosening the screw.

Table 6 Dimensions of end stopper SB

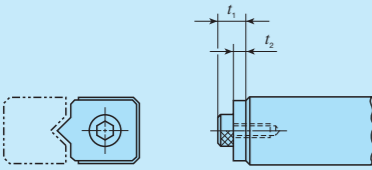

unit: mm

Size	t_1	t_2
2	4.5	2
3	5	2
4	7	3
6	8	3
9	10	4

Size	t_1	t_2
12	11	5
15	14	6
18	14	6
24	16	6

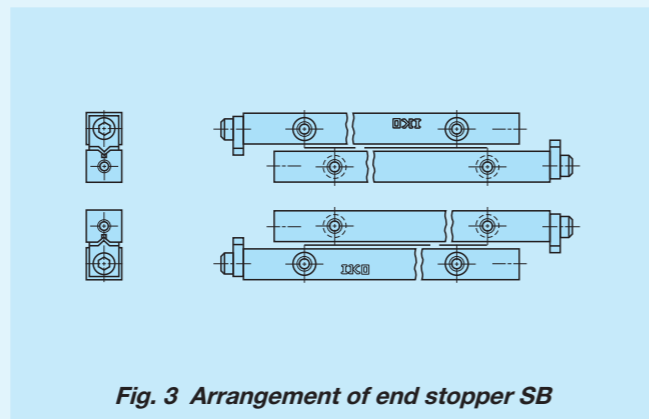
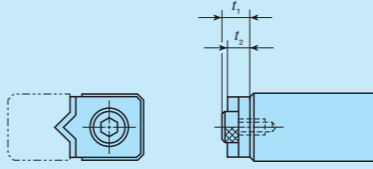

Fig. 3 Arrangement of end stopper SB

Wiper seal /U

In order to prevent foreign substances from entering into a raceway, the wiper seal is changed into the one with a function of end stopper SB.
The wiper seal cannot be mounted on all way ends. Standard mounting positions are shown in Fig. 4. The mounting positions can be changed by loosening the screw.

Table 7 Dimensions of wiper seal



unit: mm

Size	t_1	t_2
2	4.5	4
3	5	4
4	7	6
6	8	6
9	10	7.5

Size	t_1	t_2
12	11	8.5
15	14	11
18	14	11
24	16	11

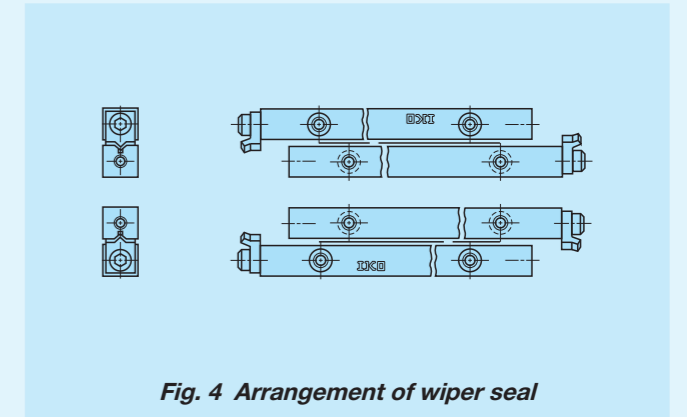

Fig. 4 Arrangement of wiper seal

Load Rating and Allowable Load

Basic dynamic load rating C , basic static load rating C_0 , and allowable load F of the CRWG series and CRWG...H series show values for downward loads in case of parallel arrangement of four ways and two pairs of roller cages as one set. (Refer to Fig. 5) In addition, the upward and lateral load rating is the same as downward load rating.

For the CRW series, since the number of cylindrical rollers that share load of each direction varies, the load rating for each load direction and allowable load must be obtained. In addition, basic dynamic load rating C_u , basic static load rating C_{ou} , and allowable load F_u in the dimension table show values per cylindrical roller.

Basic dynamic load rating C , basic static load rating C_0 , and allowable load F of the CRW series are obtained based on the equation indicated in Table 8.1 and Table 8.2.

For more information on the definition of load rating and calculated load, see page III-3.

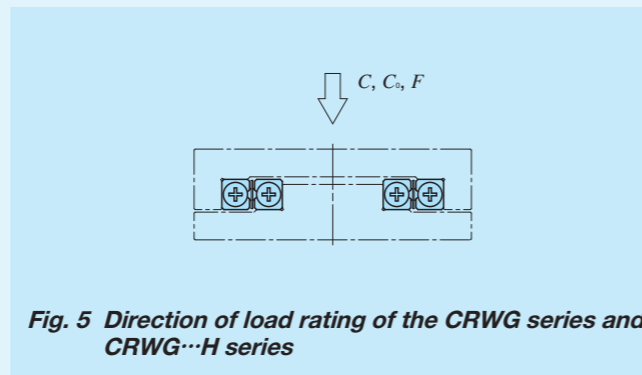

Allowable load

Allowable load refers to load of smooth rolling motion on contact surface to which maximum contact stress is applied and the sum of whose elastic deformation of rolling elements and raceway is small.

Therefore, use applied load within the allowable load range if very smooth rolling motion and high accuracy are required.

Table 8.1 Calculating formula of load rating and allowable load of standard type CRW series

Load direction	Upward and downward load ⁽¹⁾	Lateral load
Basic dynamic load rating C N	$C_r = \left\{ \left(\frac{Z}{2} - 1 \right) 2p \right\}^{1/36} \left(\frac{Z}{2} \right)^{3/4} C_u \dots \dots \dots (1)$	$C_a = \left\{ \left(\frac{Z}{2} - 1 \right) 2p \right\}^{1/36} \left(\frac{Z}{2} \right)^{3/4} 2^{7/9} C_u \dots \dots \dots (4)$
Basic static load rating C_0 N	$C_{or} = 2 \left(\frac{Z}{2} \right) C_{ou} \dots \dots \dots (2)$	$C_{oa} = 2 \left(\frac{Z}{2} \right) C_{ou} \dots \dots \dots (5)$
Allowable load F N	$F_r = 2 \left(\frac{Z}{2} \right) F_u \dots \dots \dots (3)$	$F_a = 2 \left(\frac{Z}{2} \right) F_u \dots \dots \dots (6)$
Code description	C_r : Basic dynamic load rating in case upward and downward load is applied N	
	C_a : Basic dynamic load rating in case lateral load is applied N	
	C_{or} : Basic static load rating in case upward and downward load is applied N	
	C_{oa} : Basic static load rating in case lateral load is applied N	
	F_r : Allowable load in case upward and downward load is applied N	
	F_a : Allowable load in case lateral load is applied N	
	Z : The number of cylindrical rollers incorporated in a roller cage (omit the figures after the decimal fractions for $\frac{Z}{2}$)	
	p : Inter-pitch dimensions of cylindrical rollers mm	
C_u : Basic dynamic load rating per cylindrical roller N		
C_{ou} : Basic static load rating per cylindrical roller N		
F_u : Allowable load per cylindrical roller N		

Note ⁽¹⁾ : In case of parallel arrangement in this load direction, calculation must be performed based on the equations (7) , (8) , and (9) in Table 8.2.

Table 8.2 Calculating formula of load rating and allowable load of module type CRW series

Load direction	Upward and downward load	Lateral load
Basic dynamic load rating C N	$C_r = \left\{ \left(\frac{Z}{2} - 1 \right) 2p \right\}^{1/36} \left(\frac{Z}{2} \right)^{3/4} 2^{7/9} C_u \dots \dots \dots (7)$	$C_a = \left\{ \left(\frac{Z}{2} - 1 \right) 2p \right\}^{1/36} \left(\frac{Z}{2} \right)^{3/4} 2^{7/9} C_u \dots \dots \dots (10)$
Basic static load rating C_0 N	$C_{or} = 2 \left(\frac{Z}{2} \right) C_{ou} \dots \dots \dots (8)$	$C_{oa} = 2 \left(\frac{Z}{2} \right) C_{ou} \dots \dots \dots (11)$
Allowable load F N	$F_r = 2 \left(\frac{Z}{2} \right) F_u \dots \dots \dots (9)$	$F_a = 2 \left(\frac{Z}{2} \right) F_u \dots \dots \dots (12)$
Code description	C_r : Basic dynamic load rating in case upward and downward load is applied N	
	C_a : Basic dynamic load rating in case lateral load is applied N	
	C_{or} : Basic static load rating in case upward and downward load is applied N	
	C_{oa} : Basic static load rating in case lateral load is applied N	
	F_r : Allowable load in case upward and downward load is applied N	
	F_a : Allowable load in case lateral load is applied N	
	Z : The number of cylindrical rollers incorporated in a roller cage (omit the figures after the decimal fractions for $\frac{Z}{2}$)	
	p : Inter-pitch dimensions of cylindrical rollers mm	
C_u : Basic dynamic load rating per cylindrical roller N		
C_{ou} : Basic static load rating per cylindrical roller N		
F_u : Allowable load per cylindrical roller N		

CRW(G)(...H)
CRW(G)

Selection of CRW Series

For selection of CRW series specifications, stroke length and the number of cylindrical rollers, as well as accuracy, load rating and allowable load, must be determined.

Stroke length and the number of cylindrical rollers

Stroke length of the CRW series affects the way length and the number of cylindrical rollers. Therefore, select specifications by following the procedure below taking into account the stroke length used and applied load.

1 Calculation of way length

The way length, which should be 1.5 times longer than the stroke length used, is obtained from the equation below.

$$L \geq 1.5S \quad (13)$$

Where L : Way length mm
 S : Stroke length used mm

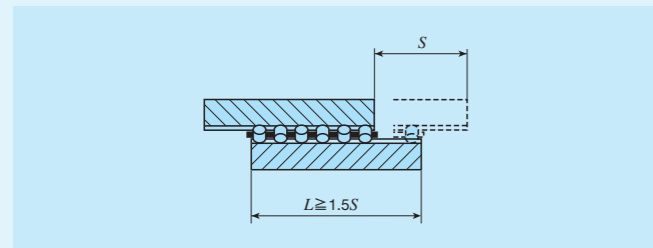

2 Calculation of maximum stroke length

Ideally the stroke length used should be less than 80% of the maximum stroke length, which is obtained from the equation below.

$$S_1 \geq \frac{1}{0.8} S \quad (14)$$

Where S_1 : Maximum stroke length mm
 S : Stroke length used mm

3 Calculation of cage length and the number of rollers

With the way length and maximum stroke length determined, the allowable length for cage can be calculated. Calculation method of the cage length varies depending on specifications of end screws and end stopper fitted to the way end.

(1) With standard end screws and end stopper SA (excluding Size 1 series)
 The dimensions between rollers at both ends is obtained from the following equation by using a value obtained by subtracting a half of the maximum stroke length from the way length.

$$L_R = L - \frac{S_1}{2} \quad (15)$$

Where L_R : Allowable dimensions between rollers at both ends mm
 L : Way length mm
 S_1 : Maximum stroke length mm

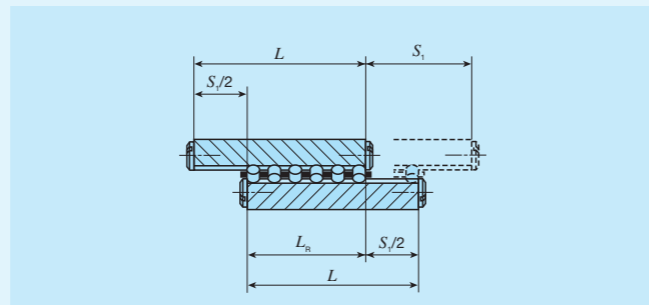

The number of rollers to be incorporated in a roller cage is obtained by the following equation.

$$Z = \frac{L_R - D_w}{p} + 1 \quad (16)$$

Where Z : Number of cylindrical rollers (figures after the decimal fractions are omitted)
 L_R : Allowed dimensions between rollers at both ends mm
 D_w : Diameter of cylindrical rollers (refer to the dimension table) mm
 p : Inter-pitch dimensions of cylindrical rollers (refer to the dimension table) mm

(2) For Size 1 series

The stroke length is regulated by cage and end stopper and the cage length is obtained by the following equation.

$$R = L - \frac{S_1}{2} \quad (17)$$

Where R : Allowable cage length mm
 L : Way length mm
 S_1 : Maximum stroke length mm

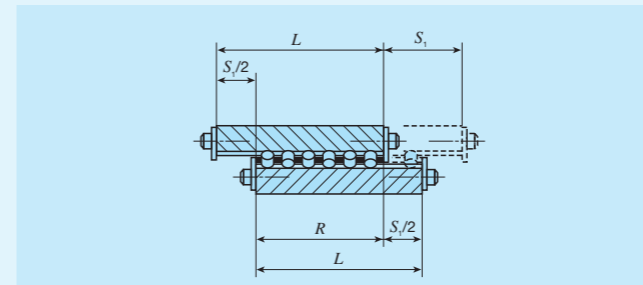

The number of rollers to be incorporated in a roller cage is obtained by the following equation.

$$Z = \frac{R - 2e}{p} + 1 \quad (18)$$

Where Z : Number of cylindrical rollers (figures after the decimal fractions are omitted)
 R : Allowable cage length mm
 e : End dimension of cage (refer to the dimension table) mm
 p : Inter-pitch dimensions of cylindrical rollers (refer to the dimension table) mm

(3) For end stopper SB and wiper seal

The stroke length is regulated by cage and end stopper or wiper seal and the cage length is obtained by the following equation.

$$R = L - t_2 - S_1 \quad (19)$$

Where R : Allowable cage length mm
 L : Way length mm
 S_1 : Maximum stroke length mm
 t_2 : Thickness of end stopper SB or wiper seal mm
 (See Table 6 in page II-13, and Table 7 in page II-14)

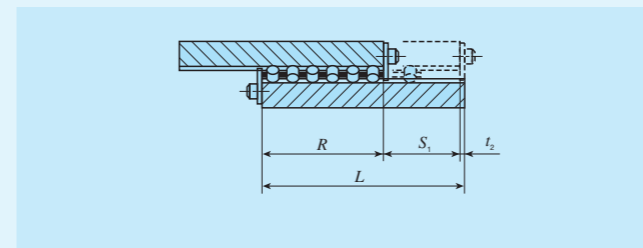

The number of rollers to be incorporated in a roller cage is obtained by the equation (18) as with the Size 1 series.

Calculation examples

Form of use CRW 6
 Applied load $P = 7000$ N
 Stroke length $S = 195$ mm

Select specifications for parallel use of Crossed Roller Way under the above conditions (refer to Fig. 26 in page II-23).

1 Calculation of way length

The way length L is calculated from the equation (13).

$$L \geq 1.5S = 1.5 \times 195 = 292.5$$

Therefore, select $L = 300$ mm based on the standard length in the dimension table.

2 Calculation of maximum stroke length

The maximum stroke length S_1 is calculated from the equation (14).

$$S_1 \geq \frac{1}{0.8} S = \frac{1}{0.8} \times 195 \approx 244$$

Allowable dimensions between rollers at both ends L_R is calculated from the equation (15).

$$L_R = L - \frac{S_1}{2} = 300 - \frac{244}{2} = 178$$

3 Calculation of the number of rollers

The number of cylindrical rollers Z is calculated from the equation (16). However, D_w and p in this form are $D_w = 6$ mm, $p = 9$ mm according to the dimension table.

$$Z = \frac{L_R - D_w}{p} + 1 = \frac{178 - 6}{9} + 1 \approx 20.1$$

Therefore, it should be $Z = 20$ by omitting figures after the decimal fractions.

4 Calculation of allowable load

Allowable load in parallel arrangement F is calculated from equation (9) described in Table 8.2 in page II-16. However, allowable load per cylindrical roller F_U is $F_U = 769$ N according to the dimension table.

$$F = 2 \left(\frac{Z}{2} \right) F_U = 2 \left(\frac{20}{2} \right) \times 769 = 15380$$

Therefore, allowable load F is larger than applied load $P = 7000$ N. When allowable load becomes smaller than applied load, it is necessary to increase the number of cylindrical rollers by extending way length, or increase the cylindrical roller diameter.

5 Determination of specifications

Specifications obtained in accordance with the above is CRW6-300 and the number of cylindrical rollers is 20.

Lubrication

Grease is not pre-packed in the CRWG series, CRWG...H series and CRW series, so please perform adequate lubrication as needed.

Both of oil lubrication and grease lubrication are available in the CRWG series, CRWG...H series and CRW series. Generally, oil lubrication should be selected for high speed or low frictional resistance, and grease lubrication for low speed. For grease lubrication, use of high-quality lithium-soap base grease is recommended. For light load and low speed, apply grease or oil to raceway, rack and pinion gear first and then reapply accordingly. However, the structure as indicated in the Fig. 6 allows for easy reapplication. In addition, since the clearance between ways is small for CRWG...H series, apply grease or oil directly to raceway for re-greasing.

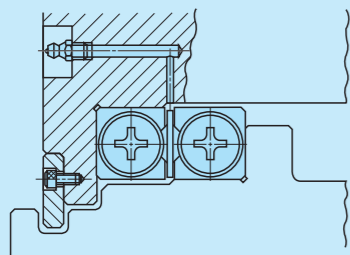

Fig. 6 Example of lubrication system

Dust Protection

Since the CRWG series, CRWG...H series and CRW series are finished with high accuracy, harmful foreign substances such as dust and particles entering into the bearing will cause low life or impaired accuracy. To prevent harmful foreign substances such as dust, particles and water from outside from entering, it is recommended to attach non-contact type labyrinth seal as indicated in Fig. 7, or contact type wiper seal as indicated in the Fig. 8 to both sides.

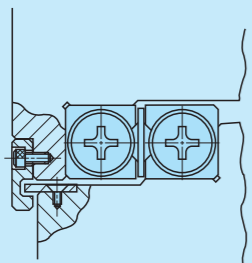

Fig. 7 Example of labyrinth seal

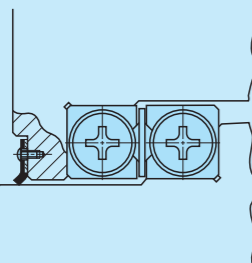

Fig. 8 Example of wiper seal

Precaution for Use

1 Handling

As the CRWG series, CRWG...H series and CRW series are designed highly precisely, take extra care for handling.

A pinion gear and cylindrical roller are incorporated with the cage for the CRWG series and CRWG...H series. When the cage is dropped or handled roughly, the pinion gear and cylindrical roller may come off. Especially for CRWG...H, grabbing the cylindrical roller may take it off, so be sure to hold the cage body for handling. In addition, do not cut off the cage as doing so may cause pinion gear coming off and breakage of gear joint section.

A rack is incorporated with the way for the CRWG series and CRWG...H series. In operation, take note that the rack may come off when the end screw is removed.

Though the cage for the CRW series may cut off to necessary length, handle it with care not to deform it when cutting.

2 Accuracy of mounting part

Examples of typical mounting surface processing are shown in Fig. 9.1 and Fig. 9.2.

General processing accuracy of mounting surface is according to Table 9. However, care should be exercised as mounting surface accuracy directly affects running accuracy. Especially when high running accuracy is required, the processing accuracy higher than that indicated in Table 9 is required.

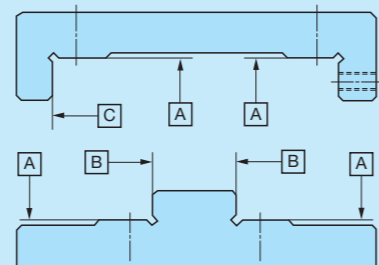

Fig. 9.1 Example of processing of CRWG, CRWG...H and CRW mounting surface

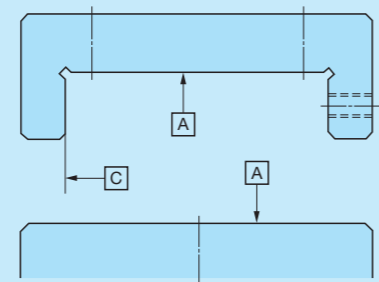

Fig. 9.2 Example of processing of CRWM mounting surface

Table 9 Accuracy of mounting part

Accuracy of A surface	<ul style="list-style-type: none"> Directly affects running accuracy. For the flatness of two mounting surfaces on table and bed sides, allowable value approximate to the parallelism indicated in Fig. 1 in page II-11 is recommended.
Accuracy of B and C surfaces	<ul style="list-style-type: none"> Flatness: Affects preload (refer to 4 Preload adjustment mechanism). II-11 Allowable value approximate to the parallelism indicated in Fig. 1 in page II-11 is recommended. Squareness: Affects rigidity in preload direction of the mounting part of the CRWG series, CRWG...H series and CRW series. Process to sufficiently high accuracy.

3 Shape of mounting part

For the opposite corner of the mating reference mounting, it is recommended to have relieved fillet as indicated in Fig. 10.

In addition, a clearance of 0.5 mm or higher should be made between the way and the mating member material.

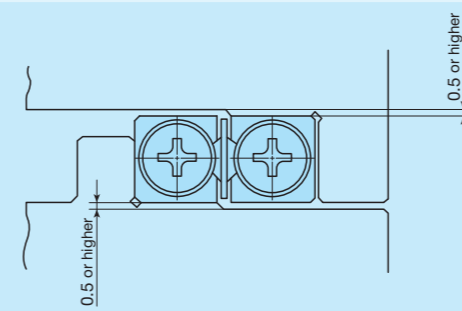

Fig. 10 Shape of mounting part

4 Preload adjustment mechanism

For use with preload, use the preload adjusting screw as indicated in Fig. 11 as a general way. Preload adjusting screw nominal dimensions and mounting position should be in accordance with the way fixing bolt dimensions and position. Press the center of the way H dimensions.

Preload amount varies depending on operational conditions of your machine and device. However, as excessive preload may lead to short life and damage on the raceway, it is typically ideal to adjust to zero clearance or slight preload state. When accuracy and rigidity are required, use a push plate or tapered jib as indicated in Fig. 12 and Fig. 13, respectively.

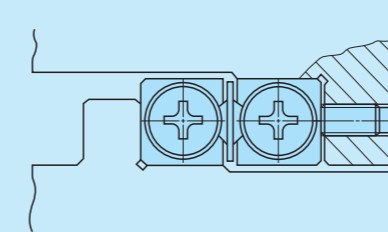

Fig. 11 Example of typical preload adjustment

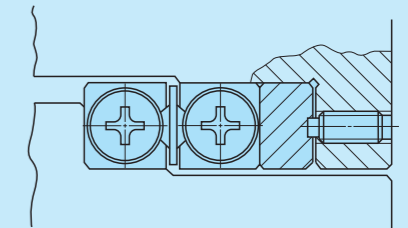

Fig. 12 Example of push plate

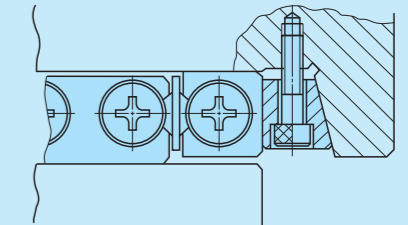

Fig. 13 Example of tapered jib

5 Operating temperature

As synthetic resin components are used for the CRWG series and CRWG...H series, the maximum operating temperature is 120°C, while it should be lower than 100°C for continuous use. When it exceeds 100°C, contact **IKO**. As synthetic resin components are not used for the CRW series, it may be used at high temperature. However, when it exceeds 100°C, contact **IKO**.

6 Maximum velocity

Operating velocity should be lower than 50 m/min for the CRWG series and CRWG...H series, and lower than 30 m/min for the CRW series.

7 Tightening torque for fixing screw

Typical tightening torque for mounting of the CRWG series, CRWG...H series and CRW series is indicated in Table 10. When vibration and shock are large or moment load is applied, it is recommended to fix by using the torque 1.3 times larger than that indicated in the table. In addition, when high running accuracy is required with no vibration and shock, it may be fixed by using torque smaller than that indicated in the table, however, it is recommended to use adhesive agent to fasten the screw, or to use stop bolts.

Table 10 Tightening torque for fixing screw

Bolt size	Tightening torque N · m
M 1.6 × 0.35	0.20
M 2 × 0.4	0.40
M 3 × 0.5	1.4
M 4 × 0.7	3.2
M 5 × 0.8	6.4
M 6 × 1	10.9
M 8 × 1.25	26.1
M10 × 1.5	51.1
M12 × 1.75	88.2
M14 × 2	140
M16 × 2	215

Remark:
When fixing screws used on the table side and bed side are not identical, fasten them all to the smaller tightening torque.

1N=0.102kgf=0.2248lbs.
1mm=0.03937inch

Mounting

Mounting of CRWG series and CRWG...H series

Typical mounting structure is shown in Fig. 14. For mounting at this point, generally follow the procedure below.

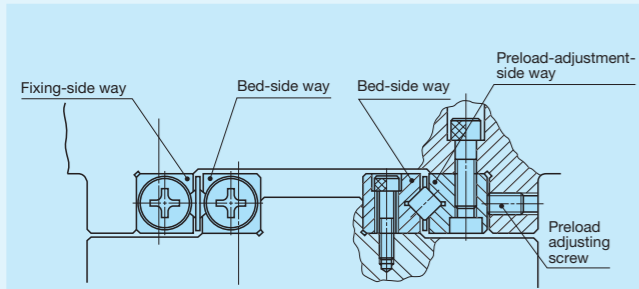

Fig. 14 Mounting example of CRWG and CRWG...H

1 Preparation for mounting

- Products are packed by set (4 ways and 2 pairs of roller cages). Be careful not to mix with other sets.
- Remove end screws and end stopper, clean up each part with clean wash fluid and then apply rust prevention and lubrication oil.

2 Cleanup of mounting surface

- Remove burrs and blemishes on the machine mounting surface with an oil-stone, etc. Be careful about corner groove on the mounting surface, too.
- Wipe off dust and dirt with clean cloth and apply rust prevention and lubrication oil lightly.

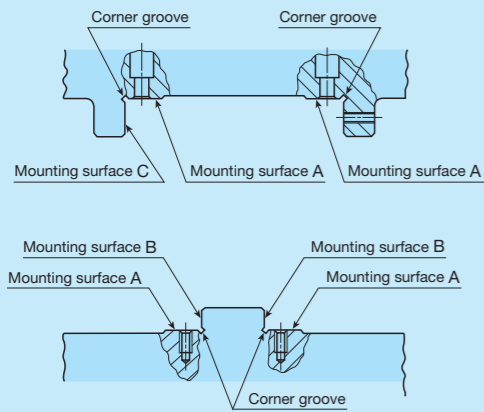

Fig. 15 Mounting surface

3 Mounting of bed-side way

- Properly align the way with mounting surface and temporarily tighten fixing screws evenly to the tightening torque.
- While making the way sticking to B surface (refer to Fig. 15) tight, fully tighten the screws to the specified torque.
- When high running accuracy is required, fully and evenly tighten them to the specified torque while checking the parallelism of the raceway along the full length of the way.
- Typical tightening torque for fixing screw is according to Table 10 in page II -20.

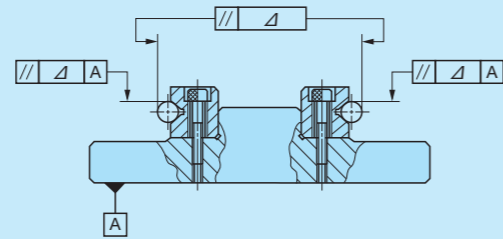

Fig. 16 Accuracy of way mounting

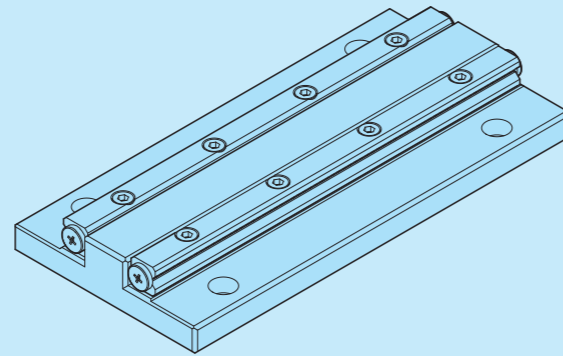

Fig. 17

4 Operation of table and bed

- Position the roller cages at the stroke end positions of the bed-side way. (Refer to Fig. 18)
- Mate the pinion gear at the center of the cage and the rack of the way.
- At this point, be careful not to deform the cage.

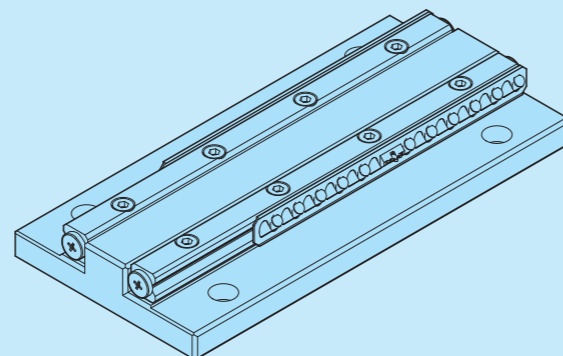

Fig. 18

- Position the table-side way in the stroke end position. (Refer to Fig. 19)
- Mate the pinion gear at the center of the cage and the rack of the table-side way.

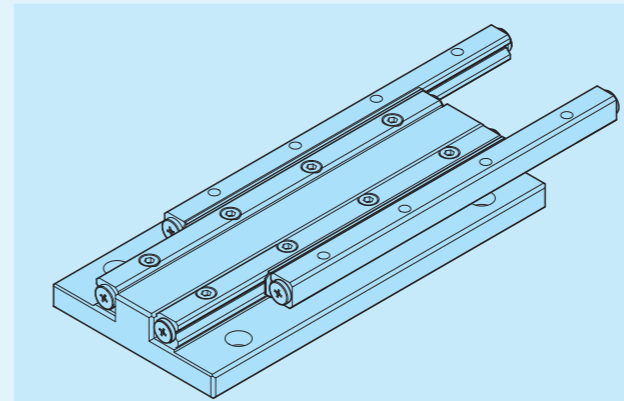

Fig. 19

- Position the table-side way approximately in the stroke center position. (Refer to Fig. 20)

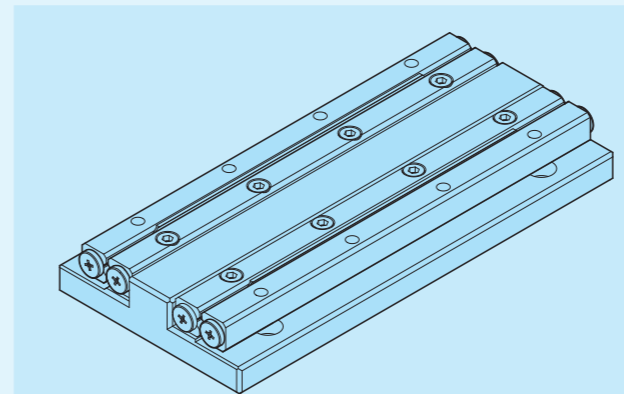

Fig. 20

- Position the table while holding the way to prevent it from moving. (Refer to Fig. 21)

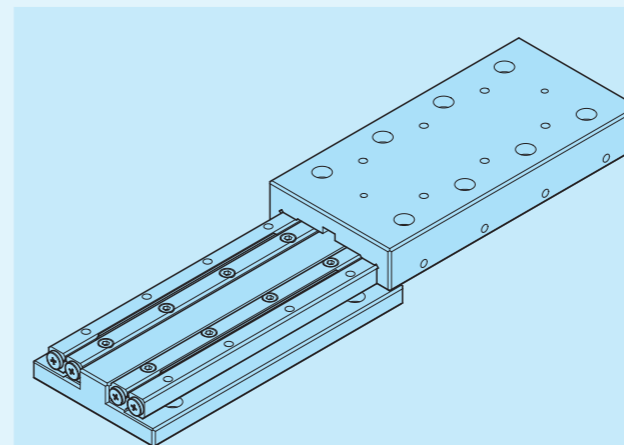

Fig. 21

- Temporarily tighten the table fixing screws. (Refer to Fig. 22)

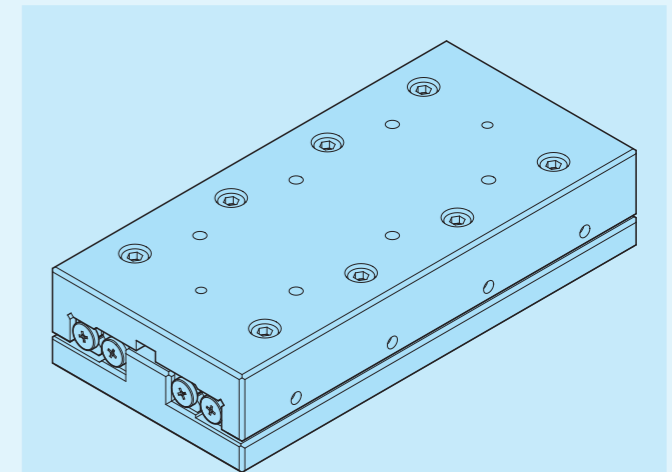

Fig. 22

- Fully stroke the table softly and check that it is within the stroke range used and cylindrical rollers on both ends of the cage do not contact with end screws of the way. If they make contact, take the procedure again. (Refer to Fig. 23)

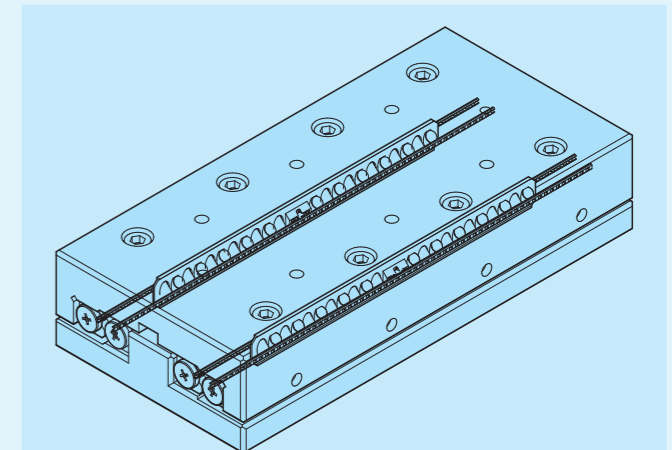

Fig. 23

5 Preload adjustment

- Preload adjustment is performed with fixing screws of the table-side way tightened temporarily.
- Preload adjustment is started from the preload adjusting screw at the center of way length and then both ends in turn.
- While measuring the clearance on the table sides, tighten the preload adjusting screws subsequently until deflection of the dial gauge stops. Measure the tightening torque for preload adjusting screws at this point.
- When adjusting preload adjusting screw near either end, stroke the table softly and check that the cylindrical roller is on the preload adjusting screw section.
- After the above procedure, the clearance becomes zero or in slight preload state, but preload is still not adjusted evenly. With the same procedure again, re-adjust all the preload adjusting screws evenly to the torque previously measured.

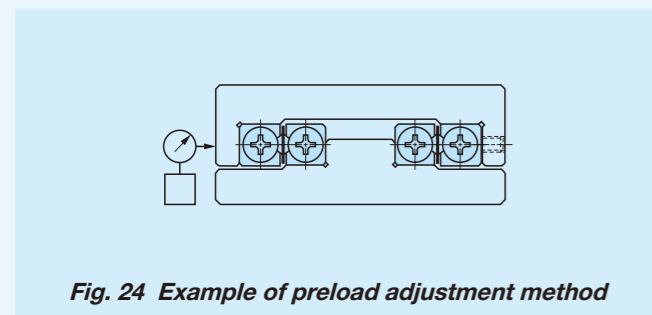

Fig. 24 Example of preload adjustment method

6 Full tightening of preload-adjustment-side way

- Fixing screws are lightly tightened to even torque. As with preload adjusting screws, temporarily fix them to torque similar to the specified torque in turn from the way center to both ends.
- When tightening fixing screws near either end, stroke the table softly and check that the cylindrical roller is on fixing screw section.
- Finally with the same procedure, fully tighten all the fixing screws evenly to the specified torque.

7 Check after assembly

- Fully stroke the table softly and check that running is smooth without abnormal noise.
- Measure the table upper and side surfaces with dial gauge or the like and check the running accuracy.

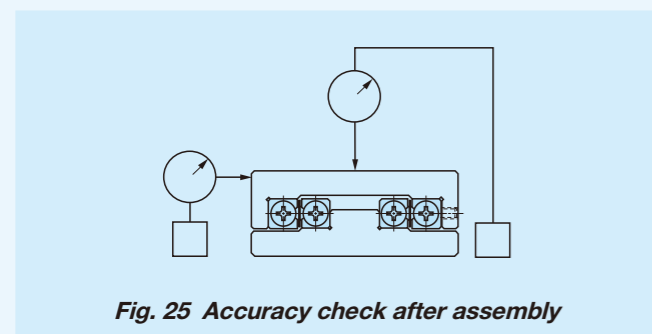

Fig. 25 Accuracy check after assembly

Mounting of standard type CRW series

Typical mounting structure is shown in Fig. 26. For mounting at this point, generally follow the procedure below.

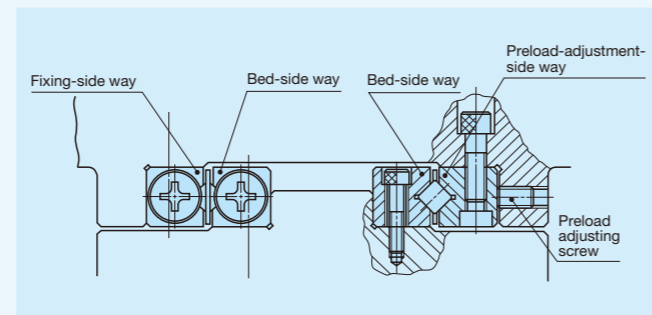

Fig. 26 Mounting example of standard type CRW series

1 Preparation for mounting

- Products are packed by set (4 ways and 2 pairs of roller cages). Be careful not to mix with other sets.
- Remove end screws and end stopper, clean up each part with clean wash fluid and then apply rust prevention and lubrication oil.

2 Cleanup of mounting surface

- Remove burrs and blemishes on the machine mounting surface with an oil-stone, etc. Be careful about corner groove on the mounting surface, too.
- Wipe off dust and dirt with clean cloth and apply rust prevention and lubrication oil lightly.

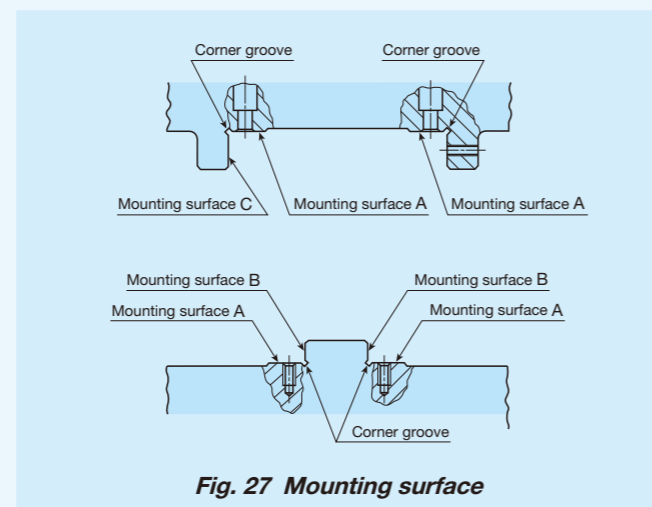

Fig. 27 Mounting surface

3 Mounting of bed-side way

- Properly align the way with mounting surface and temporarily tighten fixing screws evenly to the tightening torque.
- While making the way sticking to B surface (refer to Fig. 27) tight, fully tighten the screws to the specified torque.
- When high running accuracy is required, fully and evenly tighten them to the specified torque while checking the parallelism of the raceway along the full length of the way.
- Typical tightening torque for fixing screw is according to Table 10 in page II-20.

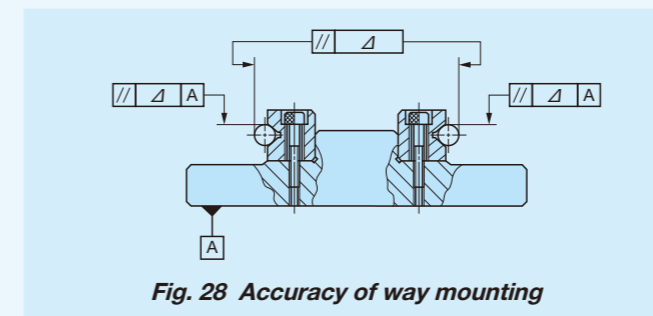

Fig. 28 Accuracy of way mounting

4 Mounting of table-side way

- Properly align the fixing-side way with mounting surface and temporarily tighten fixing screws evenly to the tightening torque.
- While making the fixing-side way sticking to C surface tight, fully tighten the screws to the specified torque.
- Set back the preload adjusting screws in advance, make the preload-adjusting-side way sticking to the mounting surface, and then temporarily tighten fixing screws lightly to the even torque.

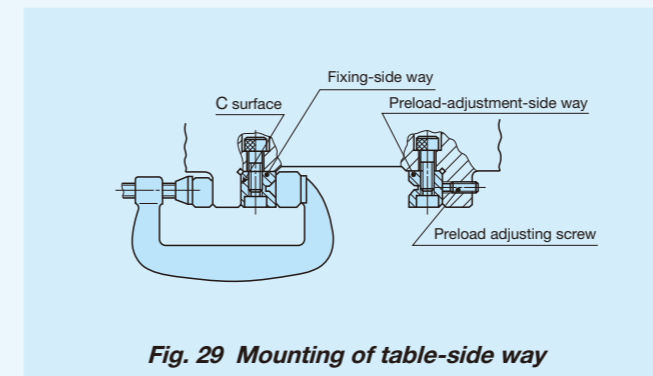

Fig. 29 Mounting of table-side way

5 Operation of table and bed

- Make alignment of the position in height and cross direction so that the roller cage can be inserted between the table-side way and bed-side way.
- Carefully insert the roller cage and assembly it at approximate center of the way length. At this point, be careful not to deform the cage.
- Mount end screws and end stopper of each way.
- Push the entire table against the preload adjusting screws and tighten the preload adjusting screws to make temporary adjustment until the clearance between ways becomes zero.
- Fully stroke the table softly and correct the roller cage position to the center.

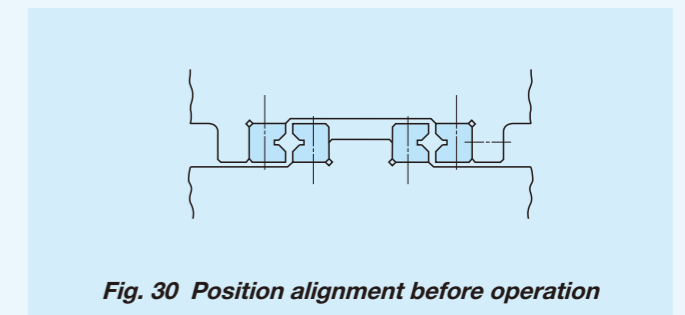

Fig. 30 Position alignment before operation

6 Preload adjustment

- Preload adjustment is performed with fixing screws of the preload-adjusting-side way tightened temporarily.
- Preload adjustment is started from the preload adjusting screw at the center of way length and then both ends in turn.
- While measuring the clearance on the table sides, tighten the preload adjusting screws subsequently until deflection of the dial gauge stops. Measure the tightening torque for preload adjusting screws at this point.
- When adjusting preload adjusting screw near either end, stroke the table softly and check that the cylindrical roller is on the preload adjusting screw section.
- After the above procedure, the clearance becomes zero or in slight preload state, but preload is still not adjusted evenly. With the same procedure again, re-adjust all the preload adjusting screws evenly to the torque previously measured.

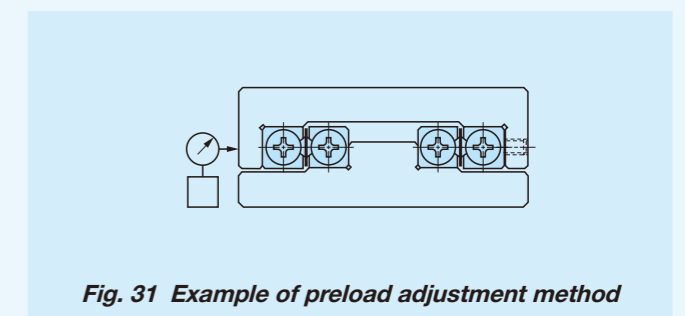

Fig. 31 Example of preload adjustment method

7 Full tightening of preload-adjustment-side way

- Fixing screws are lightly tightened to even torque. As with preload adjusting screws, temporarily fix them to torque similar to the specified torque in turn from the way center to both ends.
- When tightening fixing screws near either end, stroke the table softly and check that the cylindrical roller is on fixing screw section.
- Finally with the same procedure, fully tighten all the fixing screws evenly to the specified torque.

8 Check after assembly

- Fully stroke the table softly and check that running is smooth without abnormal noise.
- Measure the table upper and side surfaces with dial gauge or the like and check the running accuracy.

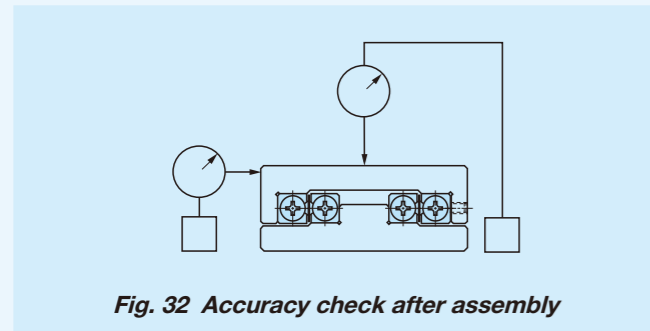

Fig. 32 Accuracy check after assembly

Mounting of module type CRW series

Typical mounting structure of CRWM is shown in Fig. 33. For mounting at this point, generally follow the procedure below.

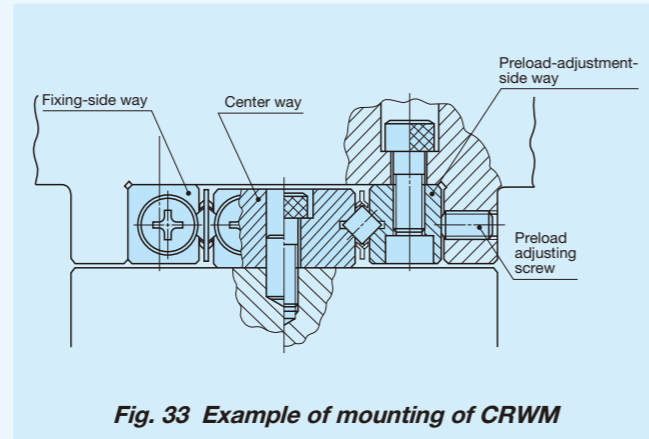

Fig. 33 Example of mounting of CRWM

1 Preparation for mounting

- Crossed Roller Way CRWM is packed by set (1 center way, 2 ways and 2 pairs of roller cages). Be careful not to mix with other sets.
- Remove end screws and end stopper, clean up each part with clean wash fluid and then apply rust prevention and lubrication oil.

2 Cleanup of mounting surface

- Remove burrs and blemishes on the machine mounting surface with an oil-stone, etc. Be careful about corner groove on the mounting surface, too.
- Wipe off dust and dirt with clean cloth and apply rust prevention and lubrication oil lightly.

3 Mounting of center way

- Roughly align the center way to the mounting surface and lightly fix it with fixing screws.
- While measuring mounting parallelism of the center way and raceway to the reference surface of running parallelism for position correction, temporarily tighten the fixing screws to the even tightening torque.
- Evenly tighten all the fixing screws to the specified tightening torque.

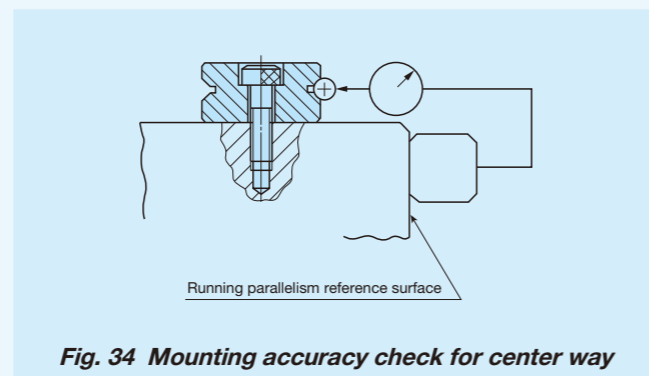

Fig. 34 Mounting accuracy check for center way

4 Processing of dowel pin hole

- When dowel pins are used, machine holes on the bed in alignment with dowel pin holes near either end of the center way.
- Dowel pin hole of the center way is finished for H7. Finish bed holes in the same way.
- Diameter and its allowance of dowel pin hole of the center way vary depending on the dimension table.
- Eliminate cutting chips and clean up again as necessary. When machines for mounting of the center way are large, clean them up with the center way removed and then reassemble.
- Load the dowel pins and check the parallelism of the reference surface of the running parallelism and the raceway of the center way again.

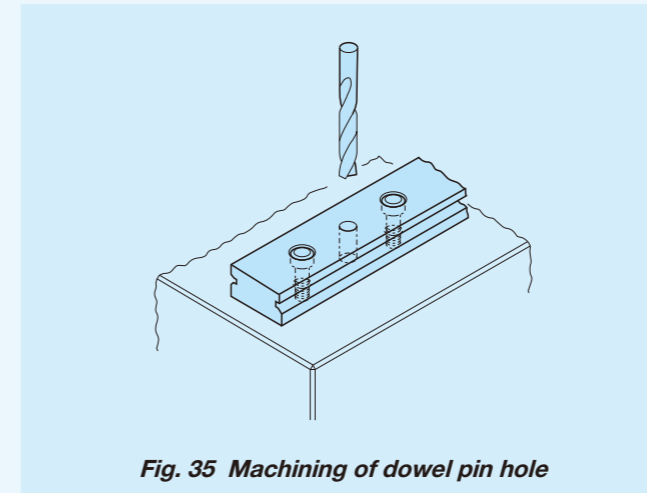

Fig. 35 Machining of dowel pin hole

5 Mounting of table-side way

- Follow the mounting of standard type CRW series.

6 Operation of table and bed

- Follow the mounting of standard type CRW series.

7 Preload adjustment

- Follow the mounting of standard type CRW series.

8 Full tightening of preload-adjustment-side way

- Follow the mounting of standard type CRW series.

9 Check after assembly

- Follow the mounting of standard type CRW series.

Mating marks module type CRW series

CRWM has mating marks to ensure the best running accuracy after mounting based on the parallelism measurement result of reference mounting surface and raceway. When assembling the ways, align the mating marks of ways with the same end side as indicated in Fig. 36.

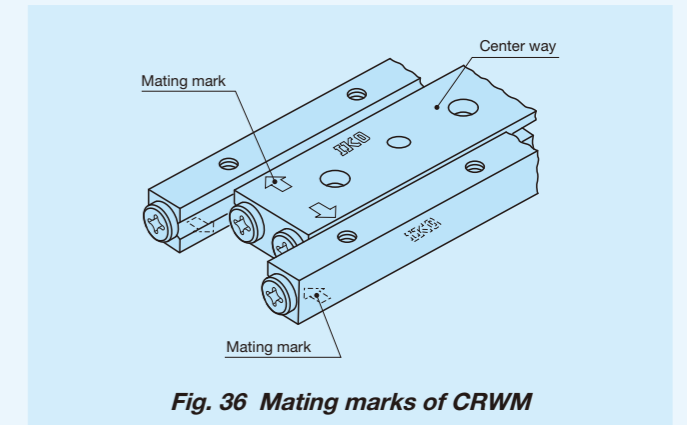
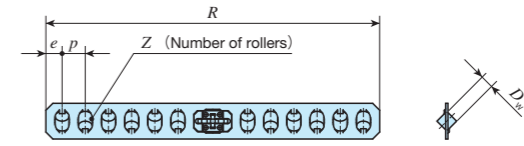
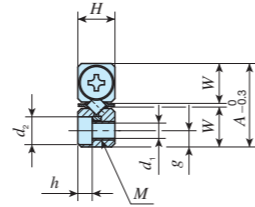
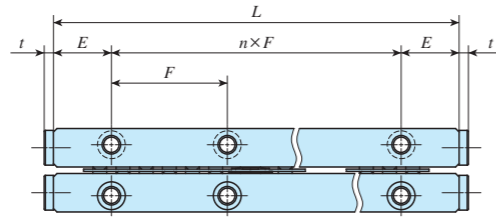

Fig. 36 Mating marks of CRWM

IKO Anti-Creep Cage Crossed Roller Way

Shape	CRWG			
Size	2	3	4	6



Identification number	Mass (Ref.)		Nominal dimensions mm																	Maximum stroke length mm	Basic dynamic load rating $C_0^{(3)}$ N	Basic static load rating $C_0^{(3)}$ N	Allowable load $F^{(3)}$ N
	Way ⁽¹⁾ g	Roller cage ⁽²⁾ g	Boundary dimensions				Dimension of roller cage				Mounting dimensions												
			A	H	$L(n \times F)$	E	D_w	R	Z	p	e	W	g	M	d_1	d_2	h	t					
CRWG 2- 30	6.53	0.38	12	6	30(1×15)	7.5	2	25.6	4	4	2.8	5.5	2.5	M3	2.55	4.4	2	1.5	9	913	1 180	392	
CRWG 2- 45	9.53	0.72			45(2×15)			41.6											8	7	1 570	2 350	783
CRWG 2- 60	12.5	0.88			60(3×15)			49.6											10	21	1 860	2 940	979
CRWG 2- 75	15.5	1.22			75(4×15)			65.6											14	19	2 420	4 110	1 370
CRWG 2- 90	18.5	1.39			90(5×15)			73.6											16	33	2 680	4 700	1 570
CRWG 2-105	21.5	1.72			105(6×15)			89.6											20	31	3 190	5 880	1 960
CRWG 2-120	24.5	1.89			120(7×15)			97.6											22	45	3 440	6 460	2 150
CRWG 2-135	27.5	2.22			135(8×15)			113.6											26	43	3 910	7 640	2 550
CRWG 2-150	30.5	2.39			150(9×15)			121.6											28	57	4 150	8 230	2 740
CRWG 3- 50	22.8	1.69			18			8											50(1×25)	12.5	3	42	6
CRWG 3- 75	33.3	2.71	75(2×25)	62		10	23		4 080	6 090	2 030												
CRWG 3-100	43.8	3.72	100(3×25)	82		14	33		5 300	8 530	2 840												
CRWG 3-125	54.4	4.74	125(4×25)	102		18	43		6 440	11 000	3 660												
CRWG 3-150	64.9	5.75	150(5×25)	122		22	53		7 530	13 400	4 470												
CRWG 3-175	75.4	6.77	175(6×25)	142		26	63		8 570	15 800	5 280												
CRWG 3-200	85.9	7.78	200(7×25)	162		30	73		9 580	18 300	6 090												
CRWG 3-225	96.4	8.80	225(8×25)	182		34	83		10 600	20 700	6 910												
CRWG 3-250	107	9.81	250(9×25)	202		38	93		11 500	23 200	7 720												

Notes ⁽¹⁾ The value shows the mass of a piece of way.
⁽²⁾ The value shows the mass of a roller cage.
⁽³⁾ This is the value when a combination of four ways and two roller cages is used in parallel arrangement.

IKO Anti-Creep Cage Crossed Roller Way

Shape	CRWG			
Size	2	3	4	6

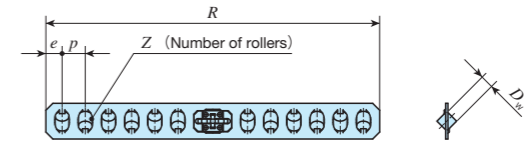
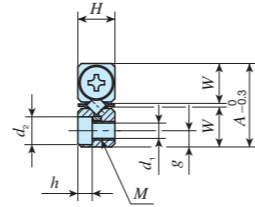
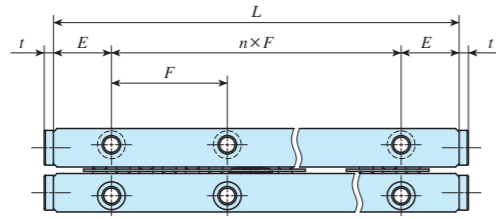

Identification number	Mass (Ref.)		Nominal dimensions mm																	Maximum stroke length mm	Basic dynamic load rating $C^{(3)}$ N	Basic static load rating $C_0^{(3)}$ N	Allowable load $F^{(3)}$ N
	Way ⁽¹⁾ g	Roller cage ⁽²⁾ g	Boundary dimensions				Dimension of roller cage				Mounting dimensions												
			A	H	$L(n \times F)$	E	D_w	R	Z	p	e	W	g	M	d_1	d_2	h	t					
CRWG 4- 80	59.6	9.70	22	11	80(1×40)	20	4	73	8	7	5	10	4.5	M5	4.3	7.5	4.1	2	14	6 690	9 400	3 130	
CRWG 4-120	88.0	12.0			120(2×40)			101	12										38	9 180	14 100	4 700	
CRWG 4-160	116	14.3			160(3×40)			129	16										62	11 500	18 800	6 270	
CRWG 4-200	145	16.7			200(4×40)			157	20										86	13 700	23 500	7 830	
CRWG 4-240	173	20.1			240(5×40)			199	26										82	16 700	30 600	10 200	
CRWG 4-280	201	22.5			280(6×40)			227	30										106	18 700	35 300	11 800	
CRWG 4-320	230	24.8			320(7×40)			255	34										129	20 600	40 000	13 300	
CRWG 6-100	147	12.0	31	15	100(1×50)	25	6	75	6	9	6	14	6	M6	5.3	9.5	5.2	3	48	11 200	13 800	4 610	
CRWG 6-150	216	22.6			150(2×50)			129	12										40	19 300	27 700	9 230	
CRWG 6-200	285	29.7			200(3×50)			165	16										68	24 100	36 900	12 300	
CRWG 6-250	353	36.8			250(4×50)			201	20										96	28 700	46 100	15 400	
CRWG 6-300	422	43.9			300(5×50)			237	24										124	33 000	55 400	18 500	
CRWG 6-350	491	51.0			350(6×50)			273	28										151	37 200	64 600	21 500	

Notes ⁽¹⁾ The value shows the mass of a piece of way.
⁽²⁾ The value shows the mass of a roller cage.
⁽³⁾ This is the value when a combination of four ways and two roller cages is used in parallel arrangement.

CRW(G)(...H)
CRWU(G)

IKO Anti-Creep Cage Crossed Roller Way H

Shape	CRWG...H			
Size	1	2	3	4

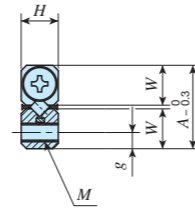
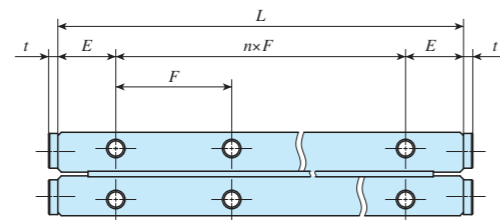

CRWG 1...H

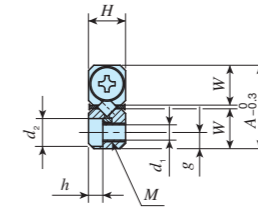
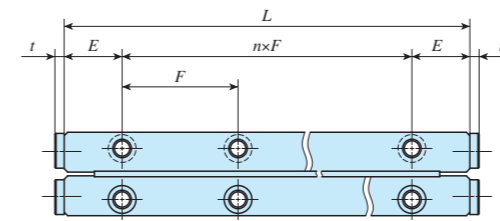

CRWG...H

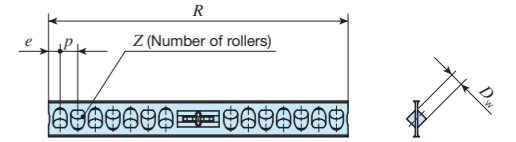

Identification number	Mass (Ref.)		Nominal dimensions mm																	Maximum stroke length mm	Basic dynamic load rating $C_0^{(3)}$ N	Basic static load rating $C_0^{(3)}$ N	Allowable load $F^{(3)}$ N
	Way ⁽¹⁾ g	Roller cage ⁽²⁾ g	Boundary dimensions				Dimension of roller cage				Mounting dimensions												
			A	H	$L(n \times F)$	E	D_w	R	Z	p	e	W	g	M	d_1	d_2	h	t					
CRWG 1- 20H	2.05	0.16	8.5	4	20(1×10)	5	1.5	16.5	6	2	1.25	3.9	1.7	M1.6	-	-	-	0.7	3	525	717	239	
CRWG 1- 30H	3.07	0.25			30(2×10)			24.5											10	7	782	1 200	398
CRWG 1- 40H	4.10	0.30			40(3×10)			28.5											12	19	901	1 430	478
CRWG 1- 50H	5.13	0.39			50(4×10)			36.5											16	23	1 130	1 910	638
CRWG 1- 60H	6.15	0.44			60(5×10)			40.5											18	35	1 230	2 150	717
CRWG 1- 70H	7.18	0.53			70(6×10)			48.5											22	39	1 440	2 630	877
CRWG 1- 80H	8.21	0.67			80(7×10)			61.5											28	35	1 740	3 350	1 120
CRWG 2- 30H	6.53	0.40			12			6											30(1×15)	7.5	2	21.7	6
CRWG 2- 45H	9.53	0.73	45(2×15)	36.7		12	12		1 860	3 000	1 000												
CRWG 2- 60H	12.5	0.95	60(3×15)	46.7		16	22		2 330	4 000	1 330												
CRWG 2- 75H	15.5	1.27	75(4×15)	61.7		22	22		2 980	5 500	1 830												
CRWG 2- 90H	18.5	1.38	90(5×15)	66.7		24	42		3 190	6 000	2 000												
CRWG 2-105H	21.5	1.71	105(6×15)	81.7		30	42		3 790	7 500	2 500												
CRWG 2-120H	24.5	1.93	120(7×15)	91.7		34	52		4 180	8 500	2 830												
CRWG 2-135H	27.5	2.26	135(8×15)	106.7		40	52		4 740	10 000	3 330												
CRWG 2-150H	30.5	2.48	150(9×15)	117.5	44	62	5 100	11 000	3 670														
CRWG 3- 50H	22.8	1.58	18	8	50(1×25)	12.5	3	41.8	8	3.8	2.5	8.6	3.5	M4	3.3	6	3.1	2	13	4 260	6 490	2 160	
CRWG 3- 75H	33.7	2.28			75(2×25)			57											12	29	5 840	9 730	3 240
CRWG 3-100H	44.7	3.33			100(3×25)			79.8											18	33	8 000	14 600	4 870
CRWG 3-125H	55.7	4.02			125(4×25)			95											22	53	9 350	17 800	5 950
CRWG 3-150H	66.7	5.07			150(5×25)			117.8											28	57	11 300	22 700	7 570
CRWG 3-175H	77.6	5.69			175(6×25)			133											32	77	12 500	26 000	8 650
CRWG 3-200H	88.6	6.81			200(7×25)			155.8											38	81	14 300	30 800	10 300
CRWG 3-225H	99.6	7.85			225(8×25)			178.6											44	86	16 000	35 700	11 900
CRWG 3-250H	111	8.55	250(9×25)	193.8	48	105	17 100	38 900	13 000														
CRWG 4- 80H	61.4	4.35	22	11	80(1×40)	20	4	59.4	10	4.8	3	10.6	4.5	M5	4.3	7.5	4.1	2	33	10 500	17 100	5 690	
CRWG 4-120H	92.7	6.80			120(2×40)			88.2											16	55	15 200	27 300	9 100
CRWG 4-160H	124	9.25			160(3×40)			117											22	78	19 500	37 500	12 500
CRWG 4-200H	155	11.7			200(4×40)			145.8											28	100	23 500	47 800	15 900
CRWG 4-240H	186	15.0			240(5×40)			184.2											36	103	28 600	61 400	20 500
CRWG 4-280H	218	17.4			280(6×40)			213											42	126	32 200	71 700	23 900
CRWG 4-320H	249	19.9	320(7×40)	241.8	48	148	35 700	81 900	27 300														

Notes ⁽¹⁾ The value shows the mass of a piece of way.
⁽²⁾ The value shows the mass of a roller cage.
⁽³⁾ This is the value when a combination of four ways and two roller cages is used in parallel arrangement.

IKO Crossed Roller Way

Standard type					
Shape	CRW CRW...SL				
Size	1	2	3	4	6
	9	12	15	18	24

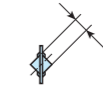
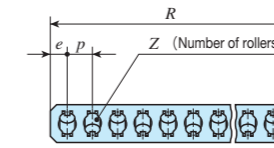
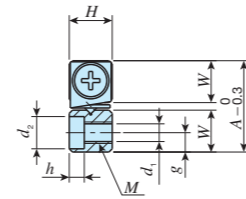
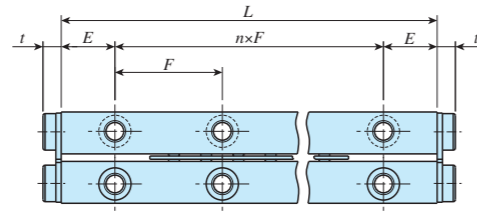

Identification number	Mass (Ref.)		Nominal dimensions mm																	Basic dynamic load rating $C_U^{(3)}$ N	Basic static load rating $C_{0U}^{(3)}$ N	Allowable load $F_U^{(3)}$ N
	Way ⁽¹⁾ kg/m	Roller cage ⁽²⁾ g	Boundary dimensions				Dimension of roller cage			Mounting dimensions												
			A	H	$L(n \times F)$	E	D_w	R	Z	p	e	W	g	M	d_1	d_2	h	t				
CRW 1- 20	0.12	0.38	8.5	4	20 (1×10)	5	1.5	16.5	5	3	2.25	3.9	1.8	M2	1.65	3	1.4	1.7	125	120	39.8	
CRW 1- 20 SL					30 (2×10)			25.5														8
CRW 1- 30					40 (3×10)			31.5														10
CRW 1- 30 SL					50 (4×10)			37.5														12
CRW 1- 40					60 (5×10)			43.5														14
CRW 1- 40 SL					70 (6×10)			52.5														17
CRW 1- 50					80 (7×10)			61.5														20
CRW 1- 50 SL																						
CRW 1- 60																						
CRW 1- 60 SL																						
CRW 1- 70																						
CRW 1- 70 SL																						
CRW 1- 80																						
CRW 1- 80 SL																						

Notes ⁽¹⁾ The value shows the mass per meter of a way.
⁽²⁾ The value shows the mass of a roller cage with ten cylindrical rollers.
⁽³⁾ The value shows the load of a cylindrical roller.

CRW(G)(...H)
CRWU(G)

IKO Crossed Roller Way

Standard type					
Shape	CRW CRW...SL				
Size	1	2	3	4	6
	9	12	15	18	24

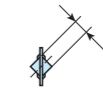
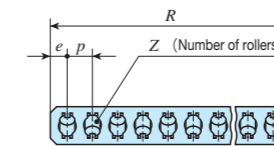
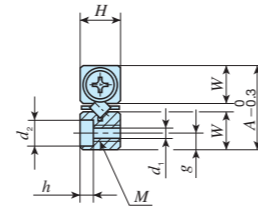
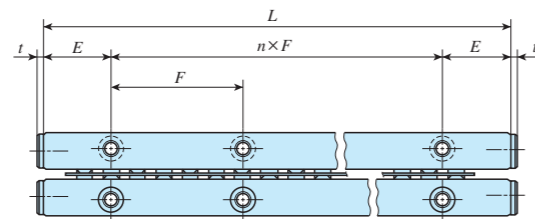

Identification number	Mass (Ref.)		Nominal dimensions mm																	Basic dynamic load rating $C_U^{(2)}$ N	Basic static load rating $C_{0U}^{(3)}$ N	Allowable load $F_U^{(3)}$ N
	Way ⁽¹⁾ kg/m	Roller cage ⁽²⁾ g	Boundary dimensions				Dimension of roller cage			Mounting dimensions												
			A	H	$L(n \times F)$	E	D_w	R	Z	p	e	W	g	M	d_1	d_2	h	t				
CRW 2- 30	0.24	0.98	12	6	30 (1×15)	7.5	2	29.6	4	2.8	5.5	2.5	M3	2.55	4.4	2	1.5	293	294	97.9		
CRW 2- 30 SL																						
CRW 2- 45					45 (2×15)			41.6													10	
CRW 2- 45 SL																						
CRW 2- 60					60 (3×15)			53.6													13	
CRW 2- 60 SL																						
CRW 2- 75					75 (4×15)			65.6													16	
CRW 2- 75 SL																						
CRW 2- 90					90 (5×15)			77.6													19	
CRW 2- 90 SL																						
CRW 2-105					105 (6×15)			89.6													22	
CRW 2-105 SL																						
CRW 2-120					120 (7×15)			101.6													25	
CRW 2-120 SL																						
CRW 2-135					135 (8×15)			113.6													28	
CRW 2-135 SL																						
CRW 2-150					150 (9×15)			125.6													31	
CRW 2-150 SL																						
CRW 2-165	165 (10×15)	137.6	34																			
CRW 2-165 SL																						
CRW 2-180	180 (11×15)	149.6	37																			
CRW 2-180 SL																						

Notes ⁽¹⁾ The value shows the mass per meter of a way.
⁽²⁾ The value shows the mass of a roller cage with ten cylindrical rollers.
⁽³⁾ The value shows the load of a cylindrical roller.

IKO Crossed Roller Way

Standard type	
Shape	CRW CRW...SL
Size	1 2 3 4 6
	9 12 15 18 24

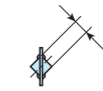
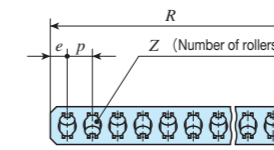
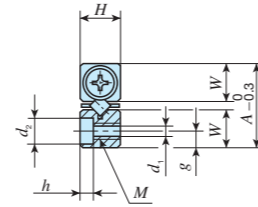
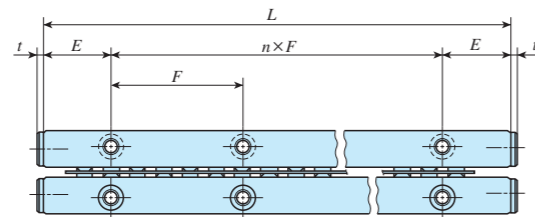

Identification number	Mass (Ref.)		Nominal dimensions mm																	Basic dynamic load rating $C_U^{(3)}$ N	Basic static load rating $C_{0U}^{(3)}$ N	Allowable load $F_U^{(3)}$ N																		
	Way ⁽¹⁾ kg/m	Roller cage ⁽²⁾ g	Boundary dimensions				Dimension of roller cage			Mounting dimensions																														
			A	H	$L(n \times F)$	E	D_w	R	Z	p	e	W	g	M	d_1	d_2	h	t																						
CRW 3- 50	0.50	2.96	18	8	50 (1×25)	12.5	3	42	28	5	3.5	8.3	3.5	M4	3.3	6	3.1	2	638	609	203																			
CRW 3- 50 SL																																								
CRW 3- 75																								75 (2×25)		62		12												
CRW 3- 75 SL																																								
CRW 3-100																								100 (3×25)		82		16												
CRW 3-100 SL																																								
CRW 3-125																								125 (4×25)		102		20												
CRW 3-125 SL																																								
CRW 3-150																								150 (5×25)		122		24												
CRW 3-150 SL																																								
CRW 3-175																								175 (6×25)		142		28												
CRW 3-175 SL																																								
CRW 3-200																								200 (7×25)		162		32												
CRW 3-200 SL																																								
CRW 3-225																								225 (8×25)		182		36												
CRW 3-225 SL																																								
CRW 3-250																								250 (9×25)		202		40												
CRW 3-250 SL																																								
CRW 3-275					275 (10×25)		222		44																															
CRW 3-275 SL																																								
CRW 3-300					300 (11×25)		242		48																															
CRW 3-300 SL																																								

Notes ⁽¹⁾ The value shows the mass per meter of a way.
⁽²⁾ The value shows the mass of a roller cage with ten cylindrical rollers.
⁽³⁾ The value shows the load of a cylindrical roller.

CRW(G)(...H)
CRW(G)

IKO Crossed Roller Way

Standard type					
Shape	CRW CRW...SL				
Size	1	2	3	4	6
	9	12	15	18	24

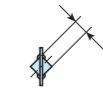
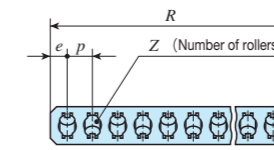
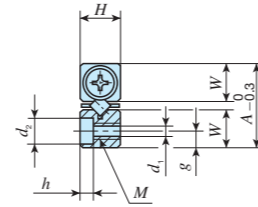
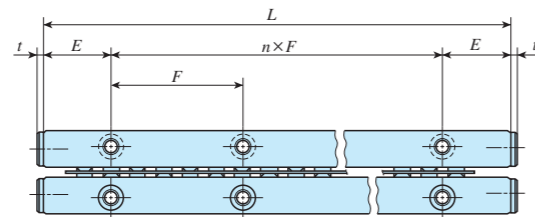

Identification number	Mass (Ref.)		Nominal dimensions mm																	Basic dynamic load rating $C_U^{(3)}$ N	Basic static load rating $C_{0U}^{(3)}$ N	Allowable load $F_U^{(3)}$ N
	Way ⁽¹⁾ kg/m	Roller cage ⁽²⁾ g	Boundary dimensions				Dimension of roller cage			Mounting dimensions												
			A	H	$L(n \times F)$	E	D_w	R	Z	p	e	W	g	M	d_1	d_2	h	t				
CRW 4- 80	0.82	6.91	22	11	80 (1×40)	20	4	73	10	7	5	10	4.5	M5	4.3	7.5	4.1	2	1 230	1 180	392	
CRW 4- 80 SL																						
CRW 4-120					120 (2×40)			101	14													
CRW 4-120 SL																						
CRW 4-160					160 (3×40)			136	19													
CRW 4-160 SL																						
CRW 4-200					200 (4×40)			164	23													
CRW 4-200 SL																						
CRW 4-240					240 (5×40)			199	28													
CRW 4-240 SL																						
CRW 4-280					280 (6×40)			227	32													
CRW 4-280 SL																						
CRW 4-320					320 (7×40)			262	37													
CRW 4-320 SL																						
CRW 4-360					360 (8×40)			297	42													
CRW 4-360 SL																						
CRW 4-400	400 (9×40)	325	46																			
CRW 4-400 SL																						
CRW 4-440	440 (10×40)	360	51																			
CRW 4-440 SL																						
CRW 4-480	480 (11×40)	388	55																			
CRW 4-480 SL																						

Notes ⁽¹⁾ The value shows the mass per meter of a way.
⁽²⁾ The value shows the mass of a roller cage with ten cylindrical rollers.
⁽³⁾ The value shows the load of a cylindrical roller.

CRW(G)(...H)
CRWU(G)

IKO Crossed Roller Way

Standard type	
Shape	CRW CRW...SL
Size	1 2 3 4 6
	9 12 15 18 24

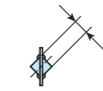
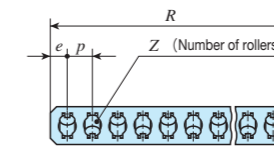
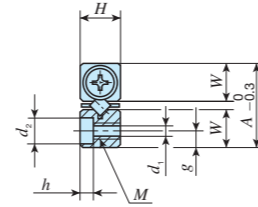
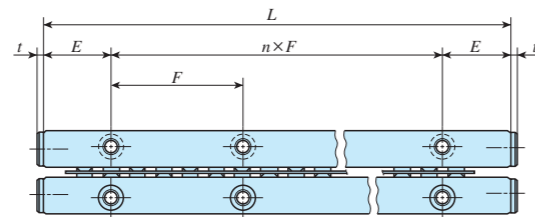

Identification number	Mass (Ref.)		Nominal dimensions mm																	Basic dynamic load rating $C_U^{(2)}$ N	Basic static load rating $C_{0U}^{(2)}$ N	Allowable load $F_U^{(2)}$ N
	Way ⁽¹⁾ kg/m	Roller cage ⁽²⁾ g	Boundary dimensions				Dimension of roller cage			Mounting dimensions												
			A	H	$L(n \times F)$	E	D_w	R	Z	p	e	W	g	M	d_1	d_2	h	t				
CRW 6-100	1.57	20.3	31	15	100 (1×50)	25	6	84	9	9	6	14	6	M6	5.3	9.5	5.2	3	2 570	2 310	769	
CRW 6-100 SL																						
CRW 6-150					150 (2×50)			129														14
CRW 6-150 SL																						
CRW 6-200					200 (3×50)			165														18
CRW 6-200 SL																						
CRW 6-250					250 (4×50)			210														23
CRW 6-250 SL																						
CRW 6-300					300 (5×50)			246														27
CRW 6-300 SL																						
CRW 6-350					350 (6×50)			282														31
CRW 6-350 SL																						
CRW 6-400					400 (7×50)			327														36
CRW 6-400 SL																						
CRW 6-450					450 (8×50)			363														40
CRW 6-450 SL																						
CRW 6-500					500 (9×50)			408														45
CRW 6-500 SL																						
CRW 6-550	550 (10×50)	444	49																			
CRW 6-550 SL																						
CRW 6-600	600 (11×50)	489	54																			
CRW 6-600 SL																						

Notes ⁽¹⁾ The value shows the mass per meter of a way.
⁽²⁾ The value shows the mass of a roller cage with ten cylindrical rollers.
⁽³⁾ The value shows the load of a cylindrical roller.

CRW(G)(...H)
CRW(G)

IKO Crossed Roller Way

Standard type					
Shape	CRW				
	Size	1	2	3	4
	9	12	15	18	24

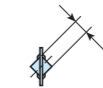
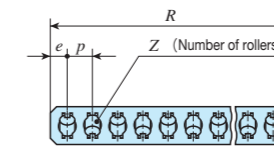
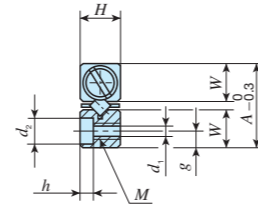
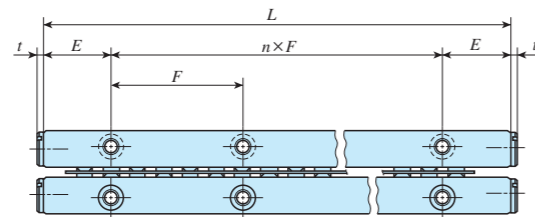

Identification number	Mass (Ref.)		Nominal dimensions mm																	Basic dynamic load rating $C_U^{(3)}$ N	Basic static load rating $C_{0U}^{(3)}$ N	Allowable load $F_U^{(3)}$ N
	Way ⁽¹⁾ kg/m	Roller cage ⁽²⁾ g	Boundary dimensions				Dimension of roller cage				Mounting dimensions											
			A	H	$L(n \times F)$	E	D_w	R	Z	p	e	W	g	M	d_1	d_2	h	t				
CRW 9- 200	3.3	64.8	44	22	200 (1×100)	50	9	173	12	14	9.5	20.2	9	M 8	6.8	10.5	6.2	3	7 190	6 600	2 200	
CRW 9- 300					300 (2×100)			257	18													
CRW 9- 400					400 (3×100)			327	23													
CRW 9- 500					500 (4×100)			411	29													
CRW 9- 600					600 (5×100)			495	35													
CRW 9- 700					700 (6×100)			565	40													
CRW 9- 800					800 (7×100)			649	46													
CRW 9- 900					900 (8×100)			733	52													
CRW 9-1000					1 000 (9×100)			817	58													
CRW 9-1100					1 100 (10×100)			887	63													
CRW 9-1200					1 200 (11×100)			971	69													
CRW 12- 200	5.57	146	58	28	200 (1×100)	50	12	168	9	18	12	26.9	12	M10	8.5	13.5	8.2	3	14 700	13 600	4 540	
CRW 12- 300					300 (2×100)			258	14													
CRW 12- 400					400 (3×100)			330	18													
CRW 12- 500					500 (4×100)			420	23													
CRW 12- 600					600 (5×100)			492	27													
CRW 12- 700					700 (6×100)			564	31													
CRW 12- 800					800 (7×100)			654	36													
CRW 12- 900					900 (8×100)			726	40													
CRW 12-1000					1 000 (9×100)			816	45													
CRW 12-1100					1 100 (10×100)			888	49													
CRW 12-1200					1 200 (11×100)			978	54													

Notes ⁽¹⁾ The value shows the mass per meter of a way.
⁽²⁾ The value shows the mass of a roller cage with ten cylindrical rollers.
⁽³⁾ The value shows the load of a cylindrical roller.

IKO Crossed Roller Way

Standard type					
Shape	CRW				
Size	1	2	3	4	6
	9	12	15	18	24

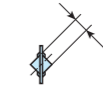
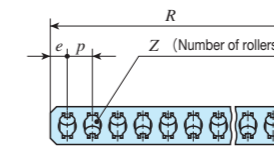
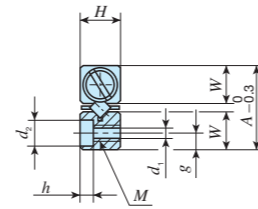
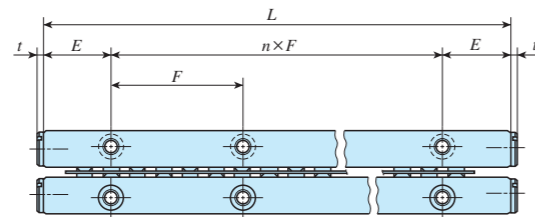

Identification number	Mass (Ref.)		Nominal dimensions mm																	Basic dynamic load rating $C_U^{(3)}$ N	Basic static load rating $C_{0U}^{(3)}$ N	Allowable load $F_U^{(3)}$ N
	Way ⁽¹⁾ kg/m	Roller cage ⁽²⁾ g	Boundary dimensions				Dimension of roller cage				Mounting dimensions											
			A	H	$L(n \times F)$	E	D_w	R	Z	p	e	W	g	M	d_1	d_2	h	t				
CRW 15- 300*	8.75	273	71	36	300 (2×100)	50	15	261	11	23	15.5	33	14	M12	10.5	16.5	10.2	5	23 800	21 900	7 300	
CRW 15- 400*					400 (3×100)			330	14													
CRW 15- 500*					500 (4×100)			422	18													
CRW 15- 600*					600 (5×100)			491	21													
CRW 15- 700*					700 (6×100)			583	25													
CRW 15- 800*					800 (7×100)			652	28													
CRW 15- 900*					900 (8×100)			744	32													
CRW 15-1000*					1 000 (9×100)			813	35													
CRW 15-1100*					1 100 (10×100)			905	39													
CRW 15-1200*					1 200 (11×100)			974	42													
CRW 18- 300*	11.3	447	83	40	300 (2×100)	50	18	262	9	28	19	38.5	18	M14	12.5	18.5	12.2	5	35 800	32 700	10 900	
CRW 18- 400*					400 (3×100)			346	12													
CRW 18- 500*					500 (4×100)			430	15													
CRW 18- 600*					600 (5×100)			514	18													
CRW 18- 700*					700 (6×100)			570	20													
CRW 18- 800*					800 (7×100)			654	23													
CRW 18- 900*					900 (8×100)			738	26													
CRW 18-1000*					1 000 (9×100)			822	29													
CRW 18-1100*					1 100 (10×100)			906	32													
CRW 18-1200*					1 200 (11×100)			990	35													

Notes ⁽¹⁾ The value shows the mass per meter of a way.
⁽²⁾ The value shows the mass of a roller cage with ten cylindrical rollers.
⁽³⁾ The value shows the load of a cylindrical roller.
 Remark: The identification numbers with * are our semi-standard items.

CRW(G)(...H)
CRWU(G)

IKO Crossed Roller Way

Standard type											
Shape	CRW										
Size	<table border="1"> <tr> <td>1</td> <td>2</td> <td>3</td> <td>4</td> <td>6</td> </tr> <tr> <td>9</td> <td>12</td> <td>15</td> <td>18</td> <td>24</td> </tr> </table>	1	2	3	4	6	9	12	15	18	24
1	2	3	4	6							
9	12	15	18	24							

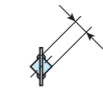
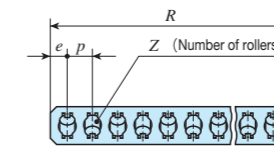
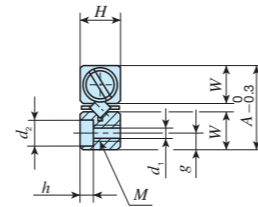
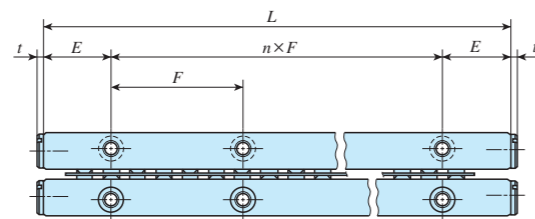

Identification number	Mass (Ref.)		Nominal dimensions mm																	Basic dynamic load rating $C_U^{(3)}$ N	Basic static load rating $C_{0U}^{(3)}$ N	Allowable load $F_U^{(3)}$ N
	Way ⁽¹⁾ kg/m	Roller cage ⁽²⁾ g	Boundary dimensions			Dimension of roller cage			Mounting dimensions													
			A	H	$L(n \times F)$	E	D_w	R	Z	p	e	W	g	M	d_1	d_2	h	t				
CRW 24- 400*	20.6	1 060	110	55	400 (3×100)	50	24	336	9	36	24	51.5	24	M16	14.5	22.5	14.2	5	69 600	63 500	21 200	
CRW 24- 500*					500 (4×100)			408	11													
CRW 24- 600*					600 (5×100)			516	14													
CRW 24- 700*					700 (6×100)			588	16													
CRW 24- 800*					800 (7×100)			660	18													
CRW 24- 900*					900 (8×100)			732	20													
CRW 24-1000*					1 000 (9×100)			840	23													
CRW 24-1100*					1 100 (10×100)			912	25													
CRW 24-1200*					1 200 (11×100)			984	27													

Notes ⁽¹⁾ The value shows the mass per meter of a way.
⁽²⁾ The value shows the mass of a roller cage with ten cylindrical rollers.
⁽³⁾ The value shows the load of a cylindrical roller.
 Remark: The identification numbers with * are our semi-standard items.

CRW(G)(...H)
CRWU(G)

IKO Crossed Roller Way

Module type				
Shape	CRWM			
Size	1	2	3	4

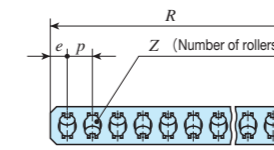
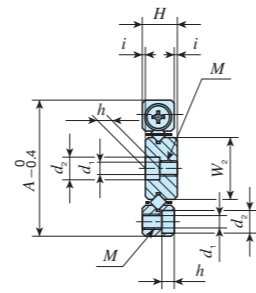
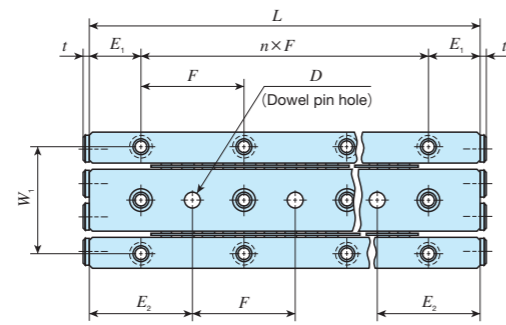

Identification number	Mass (Ref.)		Nominal dimensions and tolerances mm																				Basic dynamic load rating $C_U^{(2)}$ N	Basic static load rating $C_{0U}^{(2)}$ N	Allowable load $F_U^{(3)}$ N
	Way ⁽¹⁾ kg/m	Roller cage ⁽²⁾ g	Boundary dimensions				Dimension of roller cage				Mounting dimensions														
			A	H	$L(n \times F)$	i	D_w	R	Z	p	e	W_1	W_2	E_1	E_2	M	d_1	d_2	h	D	Dim. D tolerance	t			
CRWM 1- 20	0.49	0.38	17	4.5	20 (1×10)	0.5	1.5	16.5	5	3	2.25	13.4	7.8	5	10	M2	1.65	3	1.4	2	+0.010 0	1.7	125	120	39.8
CRWM 1- 30					30 (2×10)			25.5	8																
CRWM 1- 40					40 (3×10)			31.5	10																
CRWM 1- 50					50 (4×10)			37.5	12																
CRWM 1- 60					60 (5×10)			43.5	14																
CRWM 1- 70					70 (6×10)			52.5	17																
CRWM 1- 80					80 (7×10)			61.5	20																
CRWM 2- 30	0.99	0.98	24	6.5	30 (1×15)	0.5	2	29.6	7	4	2.8	19	11	7.5	15	M3	2.55	4.4	2	3	+0.010 0	1.5	293	294	97.9
CRWM 2- 45					45 (2×15)			41.6	10																
CRWM 2- 60					60 (3×15)			53.6	13																
CRWM 2- 75					75 (4×15)			65.6	16																
CRWM 2- 90					90 (5×15)			77.6	19																
CRWM 2-105					105 (6×15)			89.6	22																
CRWM 2-120					120 (7×15)			101.6	25																
CRWM 2-135					135 (8×15)			113.6	28																
CRWM 2-150					150 (9×15)			125.6	31																
CRWM 2-165					165 (10×15)			137.6	34																
CRWM 2-180	180 (11×15)	149.6	37																						

Notes ⁽¹⁾ The value shows the total mass per meter of a set of three ways.
⁽²⁾ The value shows the mass of a roller cage with ten cylindrical rollers.
⁽³⁾ The value shows the load of a cylindrical roller.

CRW(G)(...H)
CRWU(G)

IKO Crossed Roller Way

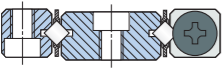
Module type				
Shape	CRWM			
				
Size	1	2	3	4

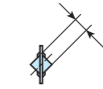
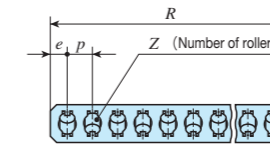
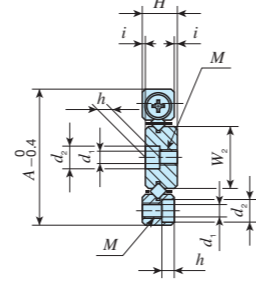
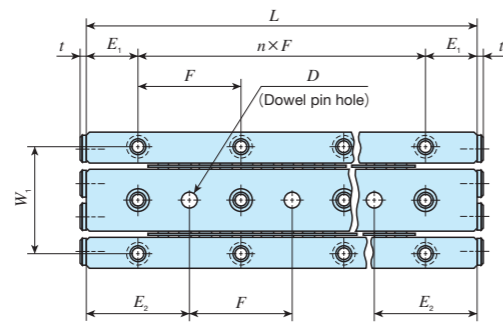

Identification number	Mass (Ref.)		Nominal dimensions and tolerances mm																				Basic dynamic load rating $C_U^{(2)}$ N	Basic static load rating $C_{0U}^{(2)}$ N	Allowable load $F_U^{(3)}$ N
	Way ⁽¹⁾ kg/m	Roller cage ⁽²⁾ g	Boundary dimensions				Dimension of roller cage				Mounting dimensions														
			A	H	$L(n \times F)$	i	D_w	R	Z	p	e	W_1	W_2	E_1	E_2	M	d_1	d_2	h	D	Dim. D tolerance	t			
CRWM 3- 50	1.99	2.96	36	8.5	50 (1×25)	0.5	3	42	8	5	3.5	29	16.6	12.5	25	M4	3.3	6	3.1	4	+0.012 0	2	638	609	203
CRWM 3- 75					75 (2×25)			62	12																
CRWM 3-100					100 (3×25)			82	16																
CRWM 3-125					125 (4×25)			102	20																
CRWM 3-150					150 (5×25)			122	24																
CRWM 3-175					175 (6×25)			142	28																
CRWM 3-200					200 (7×25)			162	32																
CRWM 3-225					225 (8×25)			182	36																
CRWM 3-250					250 (9×25)			202	40																
CRWM 3-275					275 (10×25)			222	44																
CRWM 3-300					300 (11×25)			242	48																
CRWM 4- 80	3.28	6.91	44	11.5	80 (1×40)	0.5	4	73	10	7	5	35	20	20	40	M5	4.3	7.5	4.1	5	+0.012 0	2	1 230	1 180	392
CRWM 4-120					120 (2×40)			101	14																
CRWM 4-160					160 (3×40)			136	19																
CRWM 4-200					200 (4×40)			164	23																
CRWM 4-240					240 (5×40)			199	28																
CRWM 4-280					280 (6×40)			227	32																
CRWM 4-320					320 (7×40)			262	37																
CRWM 4-360					360 (8×40)			297	42																
CRWM 4-400					400 (9×40)			325	46																
CRWM 4-440					440 (10×40)			360	51																
CRWM 4-480					480 (11×40)			388	55																

Notes ⁽¹⁾ The value shows the total mass per meter of a set of three ways.
⁽²⁾ The value shows the mass of a roller cage with ten cylindrical rollers.
⁽³⁾ The value shows the load of a cylindrical roller.



Anti-Creep Cage Crossed Roller Way Unit

CRWUG



Points

1 High rigidity and high accuracy

Since CRWG or CRW with excellent load balance is incorporated with grounded high rigidity table and bed, elastic deformation is small for load in every direction, leading to highly accurate and stable linear motion.

2 Solves cage creep issue

As CRWG with cage creep proof function is incorporated with CRWUG, there is no risk of cage creep and it works reliable in high-speed and high-tact operation, or in vertical axis.

3 Wide variation

Three types of CRWU with different sectional shapes are available with many size variations. You can select an optimal product for the specifications of your machine and device.

4 Easy mounting

Mounting surface is precisely grounded. In addition, female screws and boring are used for table and bed, respectively to ensure appropriate preload state. Therefore, highly reliable linear motion can be achieved just by fitting them to the machine and device.

Identification Number and Specification

Example of an identification number

The specification of CRWUG and CRWU series is indicated by the identification number. Indicate the identification number, consisting of a model code, width, and length for each specification to apply.

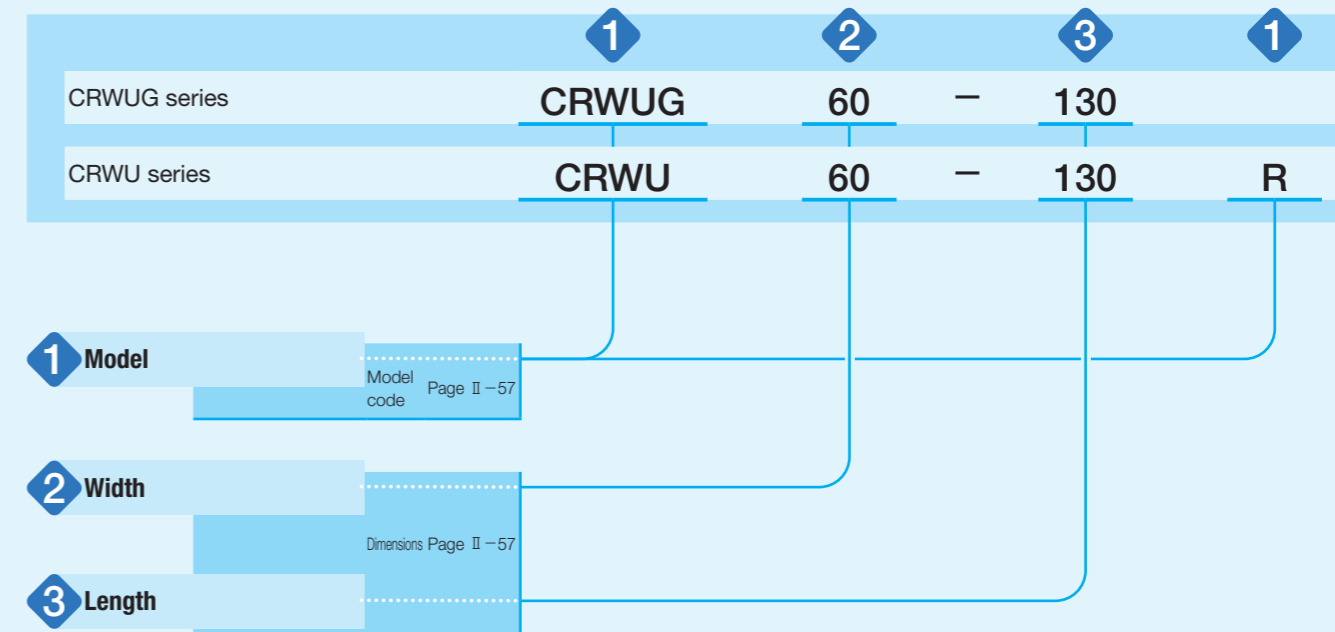

CRW(G)(...H)
CRWU(G)

Identification Number and Specification

1 Model	Anti-Creep Cage Crossed Roller Way Unit (CRWUG series)	: CRWUG
	Crossed Roller Way Unit (CRWU series)	: CRWU : CRWU...R : CRWU...RS
	For applicable models and width, see Fig. 1.	
2 Width	20, 30, 40, 60, 80, 100, 145	Indicate the table width in mm. For applicable models and width, see Table 1.
3 Length		Indicate the table length in mm.

Table 1 Models and width of CRWUG series and CRWU series

Series	Shape	Model	Characteristics	Width						
				20	30	40	60	80	100	145
CRWUG		CRWUG	A unit with cage creep proof function that realizes complete compatibility with CRWU in mounting dimensions. As external dimensions are the same, this can replace machine or device using CRWU without changing mounting dimensions, as well as new applications.	-	-	○	○	○	-	-
CRWU		CRWU	An ordinary type unit to be fixed to machine or device with bolts as it is, thanks to table and bed mounted to high accuracy.	-	○	○	○	○	○	○
		CRWU...R	Low height unit without CRWU bed. Linear motion with stable accuracy and high rigidity can be achieved for load in every direction.	-	○	○	○	○	○	○
		CRWU...RS	A compact and light unit of very simple structure. This may be used as a high-accuracy unit with small motion inertia by moving the center way.	○	○	○	-	-	-	-

Load Rating and Allowable Load

Indicate values for down direction for load rating of CRWUG and CRWU series.
In addition, the upward and lateral load rating is the same as downward load rating.
For more information on the definition of load rating and calculated load, see page III-3.

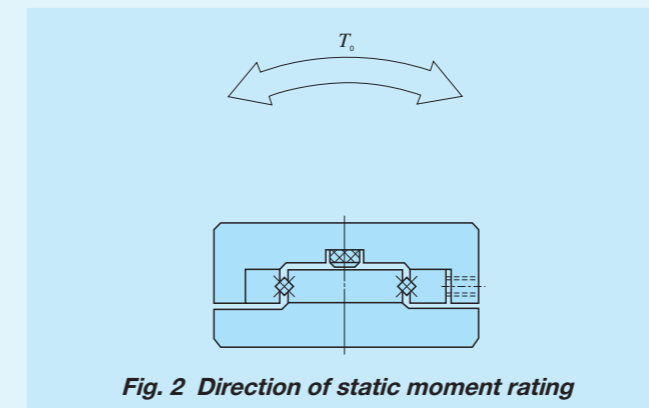
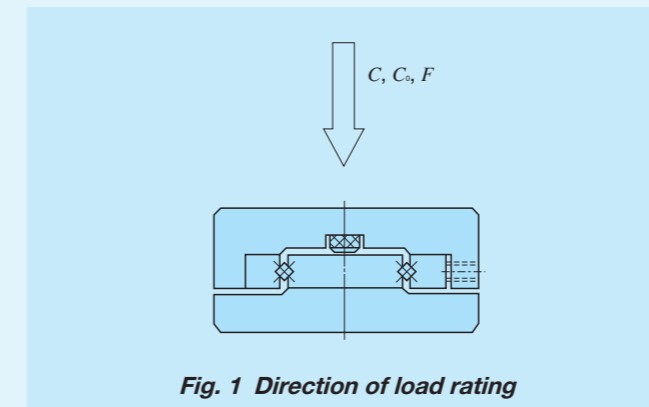

Allowable load

Allowable load refers to load of smooth rolling motion on contact surface to which maximum contact stress is applied and the sum of whose elastic deformation of rolling elements and raceway is small.
Therefore, use applied load within the allowable load range if very smooth rolling motion and high accuracy are required.

Accuracy

Accuracy of CRWUG series and CRWU series is indicated in Table 2. Parallelism at the center of the table represents parallelism of height when the table is stroked.
Parallelism at the side of the table represents parallelism of the side (preload adjusting screw side) when the table is stroked.
In addition, though allowance of unit height H is designed as ± 0.1 mm, units with height variation of less than 0.01 mm among multiple units are also available. When special accuracy is needed, contact **IKO**.

Table 2 Running accuracy

unit: μm

Unit length L mm	Parallelism at the table center	Parallelism on the table side
Over	Incl.	
-	50	4
50	100	5
100	160	6
160	310	7
310	510	8
510	710	9
710	-	10

Lubrication

Grease is not pre-packed in the CRWUG series and CRWU series, so please perform adequate lubrication as needed. Both of oil lubrication and grease lubrication are available in the CRWUG series and CRWU series. Generally, oil lubrication should be selected for high speed or low frictional resistance, and grease lubrication for low speed. For grease lubrication, use of high-quality lithium-soap base grease is recommended.

Dust Protection

Since the CRWUG series and CRWU series are finished with high accuracy, harmful foreign substances such as dust and particles entering into the bearing will cause low life or impaired accuracy. For applications in other than clean environment, cover the entire unit with a protective case, etc. to prevent harmful foreign substances such as dust, particles and water from outside from entering.

Precaution for Use

1 Handling

As the CRWUG series and CRWU series are designed highly precisely, take extra care for handling.

Cage of the CRWUG series has a pinion gear incorporated. When the cage is dropped or handled roughly, the pinion gear may come off. In addition, do not cut off the cage as doing so may cause pinion gear coming off and breakage of gear joint section.

Way of the CRWUG series has a rack incorporated. In operation, take note that the rack may come off when the end screw is removed.

For the CRWU series, the cage may be deviated from the right position due to offset load or irregular and high-velocity motion, etc. Fully stroke it once in certain operating time or certain number of reciprocating motion to correct the cage position.

2 Preload re-adjustment

Preload amount of the CRWUG series and CRWU series is adjusted to zero or slight preload state, so they may be used as they are.

Preload amount of the CRWUG series, CRWU, and CRWU...R may be re-adjusted by following the procedure below.

Preload adjustment is started from the preload adjusting screw at the center of way length and then both ends in turn, with fixing screws of the preload adjusting side way temporarily fixed.

While measuring the clearance on the table sides, tighten the preload adjusting screws subsequently until deflection of the dial gauge stops. Measure the tightening torque for preload adjusting screws at this point.

When adjusting preload adjusting screw near either end, stroke the table softly and check that the cylindrical roller is on the preload adjusting screw section.

After the above procedure, the clearance becomes zero or in slight preload state, but preload is still not adjusted evenly. With the same procedure again, re-adjust all the preload adjusting screws evenly to the torque previously measured.

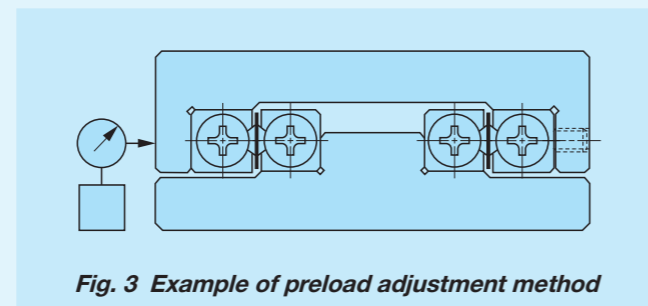

Fig. 3 Example of preload adjustment method

3 Operating temperature

As synthetic resin components are used for the CRWUG series, the maximum operating temperature is 120°C, while it should be lower than 100°C for continuous use. When it exceeds 100°C, contact **IKO**.

As synthetic resin components are not used for the CRWU series, it may be used at high temperature. However, when it exceeds 100°C, contact **IKO**.

4 Maximum velocity

Operating velocity should not exceed 30 m/min during operation.

5 Tightening torque for fixing screw

Table 3 shows typical tightening torque for mounting CRWUG Series and CRWU Series. When vibration and shock are large or moment load is applied, it is recommended to fix by using the torque 1.3 times larger than that indicated in the table. In addition, when high running accuracy is required with no vibration and shock, it may be fixed by using torque smaller than that indicated in the table, however, it is recommended to use adhesive agent to fasten the screw, or to use stop bolts.

Table 3 Tightening torque for fixing screw

Bolt size	Tightening torque N · m
M 2 ×0.4	0.40
M 2.5×0.45	0.80
M 3 ×0.5	1.4
M 4 ×0.7	3.2
M 5 ×0.8	6.4
M 6 ×1	10.9
M 8 ×1.25	26.1

6 Dowel pin hole of CRWU...R

A dowel pin hole is machined on the center way of the CRWU...R. When a dowel pin is used, machine a hole on the mounting surface of the machine after mounting of the center way.

Refer to the dimension table for diameter and its tolerances of dowel pin hole of the center way.

7 Mounting part dimensions of CRWU...R

Not to allow the table to interfere with the mounting surface, it is necessary to set mounting surface height referring to the dimensions H_1 and H in the dimension table.

Example bed mounting dimensions are indicated in Table 4.

Table 4 Example of mounting dimensions of CRWU...R bed

unit: μm

Identification number	h (minimum)	W_3	W_4
CRWU 30 ...R	0.5	13	—
CRWU 40-35R	0.5	18	—
CRWU 40 ...R		13	
CRWU 60 ...R	0.5	26.5	—
CRWU 80 ...R	0.5	38	16
CRWU100 ...R	0.5	42	14
CRWU145 ...R	1.0	68.5	28.5

IKO Anti-Creep Cage Crossed Roller Way Unit

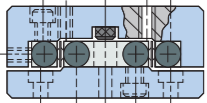
Shape			
Size	40	60	80

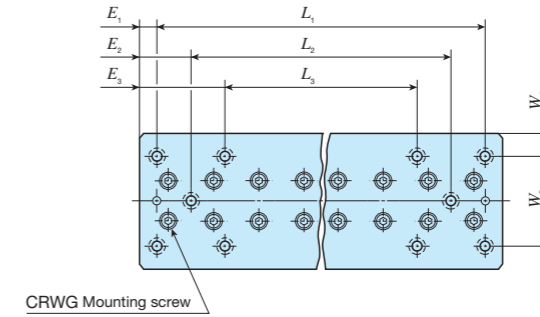
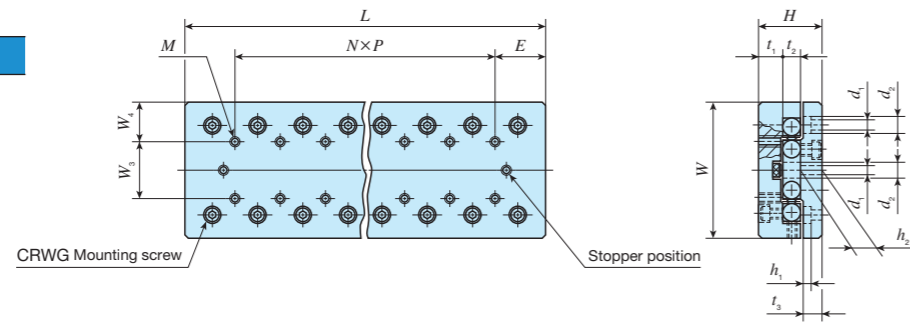

Identification number	Mass (Ref.) kg	Nominal dimensions and tolerances mm								Table mounting dimensions mm					Bed mounting dimensions mm										Basic dynamic load rating C N	Basic static load rating C ₀ N	Allowable load F N	Static moment rating T ₀ N·m						
		W	Dim. W tolerance	H	Dim. H tolerance	L	t ₁	t ₂	t ₃	Maximum stroke length	W ₃	W ₄	N×P	E	M	W ₅	W ₆	L ₁	E ₁	L ₂	E ₂	L ₃	E ₃	d ₁					d ₂	h ₁	h ₂			
CRWUG 40- 35	0.21	40	±0.1	21	±0.1	35	8	6	6.5	18	15	12.5	3×15	17.5	M3	30	5	25	5.0	-	-	-	-	3.5	6	3.2	6	913	1 180	392	10.6			
CRWUG 40- 50	0.30					50	1×15	40	2 000	2 440								813										17.7						
CRWUG 40- 65	0.36					65	2×15	55	2 000	2 440								813										17.7						
CRWUG 40- 80	0.47					80	7	8	5.5	50								3×15										70	40	20	3 430	4 880	1 630	35.3
CRWUG 40- 95	0.53					95	4×15	85	2 740	3 660								1 220										26.5						
CRWUG 40-110	0.63					110	5×15	70	4 080	6 090								2 030										44.2						
CRWUG 40-125	0.70					125	6×15	85	4 080	6 090								2 030										44.2						
CRWUG 60- 55	0.67					60	±0.1	28	±0.1	55								10.5										8	9	30	25	17.5	27.5	M4
CRWUG 60- 80	0.99	80	1×25	60	3 430					4 880	1 630	70.7																						
CRWUG 60-105	1.28	105	2×25	85	4 700					7 310	2 440	106																						
CRWUG 60-130	1.57	130	3×25	110	5 300					8 530	2 840	124																						
CRWUG 60-155	1.86	155	4×25	135	6 440					11 000	3 660	159																						
CRWUG 80- 85	1.78	80	±0.1	35	±0.1					85	13	11	10.5	50	40	20	42.5		M5	60	10	65	22.5	-	-	-	-			5.5				
CRWUG 80-125	2.56					125	1×40	80	7 960	11 800				3 920				241																
CRWUG 80-165	3.34					165	2×40	105	9 180	14 100				4 700				289																
CRWUG 80-205	4.12					205	3×40	135	11 500	18 800				6 270				385																
																						160						80	62.5					

CRW(G)(...H)
CRW(G)

IKO Crossed Roller Way Unit

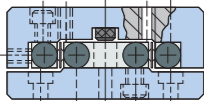
Shape						
Size	30	40	60	80	100	145

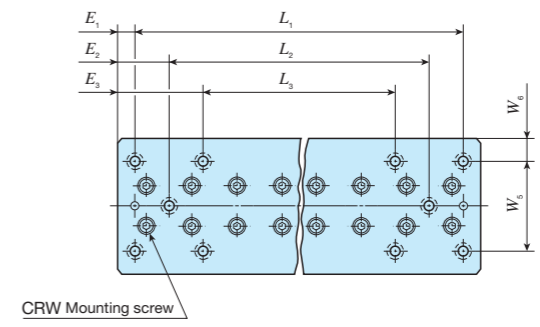
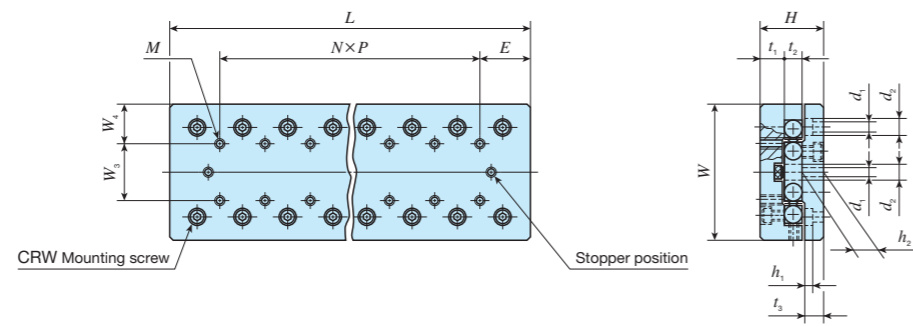

Identification number	Mass (Ref.) kg	Nominal dimensions and tolerances mm								Table mounting dimensions mm					Bed mounting dimensions mm										Basic dynamic load rating C N	Basic static load rating C ₀ N	Allowable load F N	Static moment rating T ₀ N·m					
		W	Dim. W tolerance	H	Dim. H tolerance	L	t ₁	t ₂	t ₃	Maximum stroke length	W ₃	W ₄	N x P	E	M	W ₅	W ₆	L ₁	E ₁	L ₂	E ₂	L ₃	E ₃	d ₁					d ₂	h ₁	h ₂		
CRWU 30- 25	0.09	30	±0.1	17	±0.1	25	7	4	5.5	12	10	10	-	12.5	M2	22	4	18	3.5	-	-	-	-	2.55	4.1	2.5	6	380	478	159	3.2		
CRWU 30- 35	0.13					35				18			1 x 10					28										-	-	525	717	239	4.8
CRWU 30- 45	0.17					45				25			2 x 10					38										-	-	659	956	319	6.5
CRWU 30- 55	0.20					55				32			3 x 10					48										28	13.5	786	1 200	398	8.1
CRWU 30- 65	0.24					65				40			4 x 10					58										38		906	1 430	478	9.7
CRWU 30- 75	0.28					75				45			5 x 10					68										45		1 020	1 670	558	11.3
CRWU 30- 85	0.32					85				50			6 x 10					78										58	1 140	1 910	638	12.9	
CRWU 40- 35	0.21	40	±0.1	21	±0.1	35	7	8	5.5	18	15	12.5	-	17.5	M3	30	5	25	5	-	-	-	-	3.5	6	3.2	6	896	1 180	392	10.6		
CRWU 40- 50	0.30					50				30			1 x 15					40										-	-	2 710	3 660	1 220	26.5
CRWU 40- 65	0.37					65				40			2 x 15					55										-	-	2 710	3 660	1 220	26.5
CRWU 40- 80	0.48					80				50			3 x 15					70										40	20	4 050	6 090	2 030	44.2
CRWU 40- 95	0.54					95				60			4 x 15					85										55		3 400	4 880	1 630	35.3
CRWU 40-110	0.65					110				70			5 x 15					100										70		4 680	7 310	2 440	53.0
CRWU 40-125	0.72					125				80			6 x 15					115										85	4 680	7 310	2 440	53.0	
CRWU 60- 55	0.68	60	±0.1	28	±0.1	55	10.5	8	9	30	25	17.5	-	27.5	M4	40	10	35	10	-	-	-	-	4.5	7.5	4.5	9.5	2 710	3 660	1 220	51.2		
CRWU 60- 80	1.0					80				45			1 x 25					60										-	-	4 050	6 090	2 030	85.3
CRWU 60-105	1.3					105				60			2 x 25					85										-	-	5 270	8 530	2 840	119
CRWU 60-130	1.6					130				75			3 x 25					110										85	35	5 860	9 750	3 250	137
CRWU 60-155	1.9					155				90			4 x 25					135										110		6 970	12 200	4 060	171
CRWU 60-180	2.2					180				105			5 x 25					160										110		8 040	14 600	4 880	205
CRWU 60-205	2.5					205				130			6 x 25					185										135	8 550	15 800	5 280	222	

CRW(G)(...H)
CRWU(G)

IKO Crossed Roller Way Unit

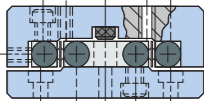
Shape						
Size	30	40	60	80	100	145

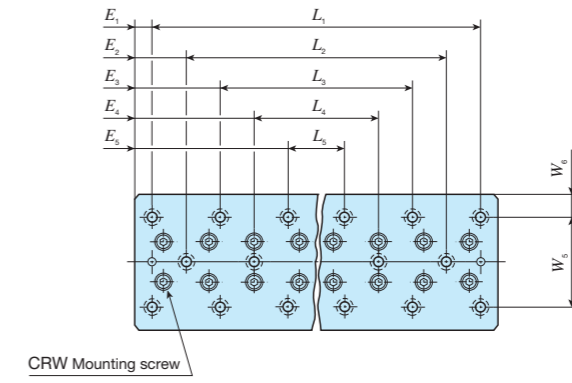
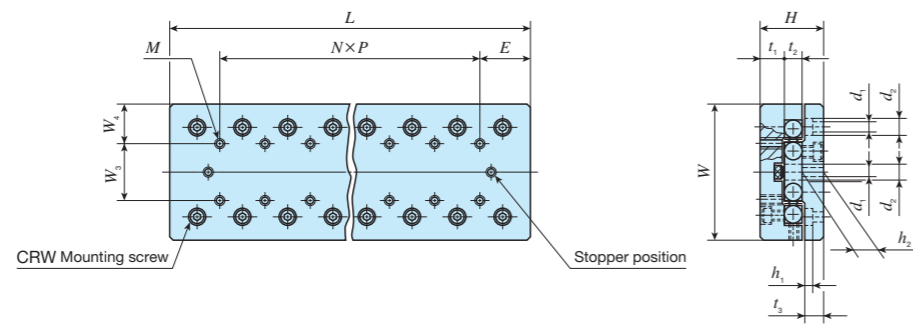

Identification number	Mass (Ref.) kg	Nominal dimensions and tolerances mm								Table mounting dimensions mm						Bed mounting dimensions mm												Basic dynamic load rating C N	Basic static load rating C ₀ N	Allowable load F N	Static moment rating T ₀ N·m					
		W	Dim. W tolerance	H	Dim. H tolerance	L	t ₁	t ₂	t ₃	Maximum stroke length	W ₃	W ₄	N x P	E	M	W ₅	W ₆	L ₁	E ₁	L ₂	E ₂	L ₃	E ₃	L ₄	E ₄	L ₅	E ₅					d ₁	d ₂	h ₁	h ₂	
CRWU 80-85	1.8	80	±0.1	35	±0.1	85	13	11	10.5	50	40	20	3 x 40	42.5	M5	60	10	65	10	22.5	-	-	80	62.5	-	-	-	-	5.5	9.5	6	11	6 640	9 400	3 130	188
CRWU 80-125	2.6					125				75								1 x 40	80														9 130	14 100	4 700	282
CRWU 80-165	3.4					165				105								2 x 40	120														10 300	16 500	5 480	329
CRWU 80-205	4.2					205				135								3 x 40	160														12 500	21 200	7 050	423
CRWU 80-245	5.1					245				155								4 x 40	200														14 700	25 900	8 620	517
CRWU 80-285	5.9					285				185								5 x 40	240														16 700	30 600	10 200	611
CRWU 80-325	6.7					325				215								6 x 40	280														18 700	35 300	11 800	705
CRWU 100-110*	3.6					100				±0.15								45	±0.1														110	16	15	13
CRWU 100-160*	5.2	160	95	1 x 50	140		16 600	23 100	7 690		519																									
CRWU 100-210*	6.9	210	130	2 x 50	190		21 600	32 300	10 800		727																									
CRWU 100-260*	8.5	260	165	3 x 50	240		26 300	41 500	13 800		934																									
CRWU 100-310*	10.2	310	200	4 x 50	290		30 800	50 700	16 900		1 140																									
CRWU 100-360*	11.8	360	235	5 x 50	340		35 100	60 000	20 000		1 350																									
CRWU 100-410*	13.5	410	265	6 x 50	390		37 200	64 600	21 500		1 450																									
CRWU 145-210*	13.2	145	±0.2	60	±0.1		210	21	22		16	130	85	30	3 x 100	105	M8			90	27.5	100	55	-	-	-	-	-	-	-	-	9	14			
CRWU 145-310*	19.6					310	180			1 x 100		200						61 200	92 300			30 800												3 320		
CRWU 145-410*	25.9					410	350			2 x 100		300						67 900	106 000			35 200												3 800		
CRWU 145-510*	32.2					510	450			3 x 100		400						74 400	119 000			39 600												4 270		
CRWU 145-610*	38.6					610	550			4 x 100		500						87 100	145 000			48 400												5 220		
CRWU 145-710*	45.0					710	650			5 x 100		600						99 200	172 000			57 200												6 170		
CRWU 145-810*	51.3					810	750			6 x 100		700						111 000	198 000			66 000												7 120		

Remark: The identification numbers with * are our semi-standard items.

CRW(G)(...H)
CRWU(G)

IKO Crossed Roller Way Unit

Shape	CRWU...R					
Size	30	40	60	80	100	145

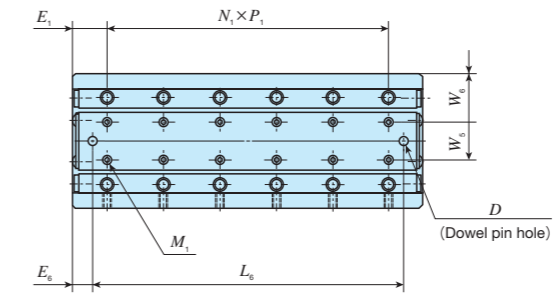
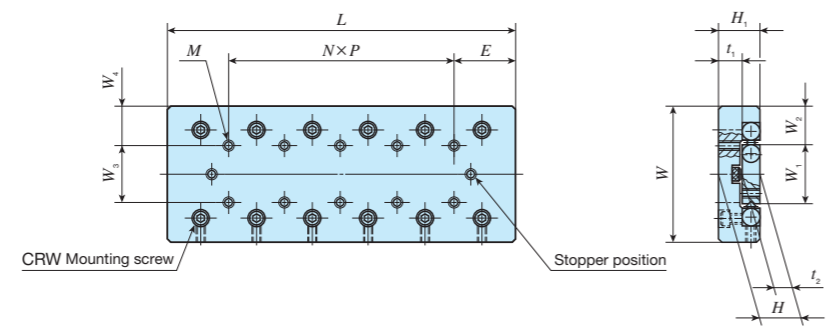

Identification number	Mass (Ref.) kg	Nominal dimensions and tolerances mm						Table mounting dimensions mm							Center way mounting dimensions and tolerances mm											Basic dynamic load rating C N	Basic static load rating C ₀ N	Allowable load F N	Static moment rating T ₀ N·m											
		W	Dim. W tolerance	H	Dim. H tolerance	L	Maximum stroke length	W ₃	W ₄	N×P	E	M	H ₁	t ₁	W ₅	W ₆	N ₁ ×P ₁	E ₁	M ₁	D	Dim. D tolerance	L ₆	E ₆	W ₁	W ₂					t ₂										
CRWU 30- 25R	0.06	30	±0.1	11	±0.1	25	12	10	10	—	12.5	M2	11	7	—	15	1×10	7.5	M2	—	—	—	—	12.8	8.6	4	380	478	159	3.2										
CRWU 30- 35R	0.08					35	18			1×10							2×10										4×10	5×10	6×10	7×10	2	+0.020 0	30	40	50	60	786	1 200	398	8.1
CRWU 30- 45R	0.11					45	25			2×10							3×10										4×10	5×10	6×10	7×10	2	+0.020 0	30	40	50	60	906	1 430	478	9.7
CRWU 30- 55R	0.13					55	32			3×10							4×10										5×10	6×10	7×10	2	+0.020 0	30	40	50	60	1 020	1 670	558	11.3	
CRWU 30- 65R	0.16					65	40			4×10							5×10										6×10	7×10	2	+0.020 0	30	40	50	60	1 140	1 910	638	12.9		
CRWU 30- 75R	0.18					75	45			5×10							6×10										7×10	2	+0.020 0	30	40	50	60	1 140	1 910	638	12.9			
CRWU 30- 85R	0.21					85	50			6×10							7×10										2	+0.020 0	30	40	50	60	1 140	1 910	638	12.9				
CRWU 40- 35R	0.13					40	±0.1			14							±0.1										35	18	15	12.5	—	17.5	M3	15	7	—	20	1×15	10	M3
CRWU 40- 50R	0.21	50	30	1×15	2×15			4×15	5×15	5×15	25	3	+0.020 0	45	17.5	25		32.5	2 710	3 660	1 220	26.5																		
CRWU 40- 65R	0.26	65	40	2×15	3×15			4×15	5×15	5×15	25	3	+0.020 0	45	17.5	25		32.5	2 710	3 660	1 220	26.5																		
CRWU 40- 80R	0.34	80	50	3×15	4×15			5×15	5×15	25	3	+0.020 0	45	17.5	25	32.5		4 050	6 090	2 030	44.2																			
CRWU 40- 95R	0.38	95	60	4×15	5×15			5×15	25	3	+0.020 0	45	17.5	25	32.5	3 400		4 880	1 630	35.3																				
CRWU 40-110R	0.46	110	70	5×15	5×15			25	3	+0.020 0	45	17.5	25	32.5	4 680	7 310		2 440	53.0																					
CRWU 40-125R	0.50	125	80	6×15	5×15			25	3	+0.020 0	45	17.5	25	32.5	4 680	7 310		2 440	53.0																					
CRWU 60- 55R	0.44	60	±0.1	18.5	±0.1			55	30	25	17.5	—	27.5	M4	18.5	10.5		—	17	1×25	15	M4	4	+0.020 0	10	26.6	16.7	8			2 710							3 660		
CRWU 60- 80R	0.66					80	45	1×25	2×25			4×25					5×25			6×25									7×25	4	+0.020 0	10	26.6	16.7	8	4 050	6 090	2 030	85.3	
CRWU 60-105R	0.85					105	60	2×25	3×25			4×25					5×25			6×25									7×25	4	+0.020 0	10	26.6	16.7	8	5 270	8 530	2 840	119	
CRWU 60-130R	1.1					130	75	3×25	4×25			5×25					6×25			7×25									4	+0.020 0	10	26.6	16.7	8	5 860	9 750	3 250	137		
CRWU 60-155R	1.3					155	90	4×25	5×25			6×25					7×25			4									+0.020 0	10	26.6	16.7	8	6 970	12 200	4 060	171			
CRWU 60-180R	1.5					180	105	5×25	6×25			7×25					4			+0.020 0									10	26.6	16.7	8	8 040	14 600	4 880	205				
CRWU 60-205R	1.7					205	130	6×25	7×25			4					+0.020 0			10									26.6	16.7	8	8 550	15 800	5 280	222					

CRW(G)(...H)
CRW(G)

IKO Crossed Roller Way Unit

Shape	CRWU...R					
Size	30	40	60	80	100	145

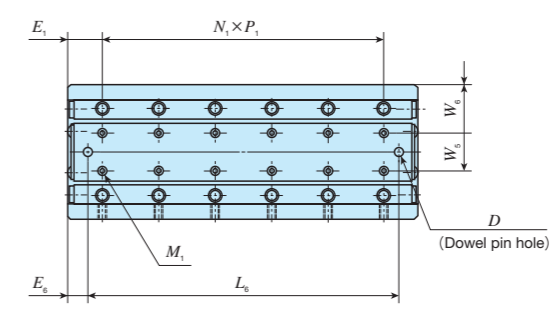
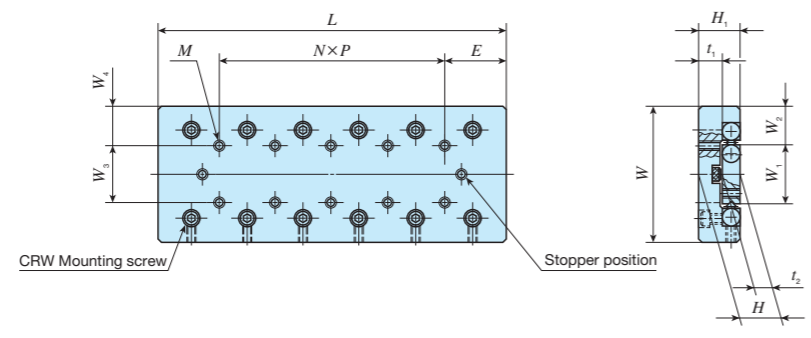

Identification number	Mass (Ref.) kg	Nominal dimensions and tolerances mm					Table mounting dimensions mm							Center way mounting dimensions and tolerances mm											Basic dynamic load rating C N	Basic static load rating C ₀ N	Allowable load F N	Static moment rating T ₀ N·m		
		W	Dim. W tolerance	H	Dim. H tolerance	L	Maximum stroke length	W ₃	W ₄	N×P	E	M	H ₁	t ₁	W ₅	W ₆	N ₁ ×P ₁	E ₁	M ₁	D	Dim. D tolerance	L ₀	E ₀	W ₁					W ₂	t ₂
CRWU 80- 85R	1.2	80	±0.1	24	±0.1	85	50	40	20	—	42.5	M5	24	13	27	26.5	1×40	22.5	M5	5	+0.020 0	55	15	38	21	11	6 640	9 400	3 130	188
CRWU 80-125R	1.8					125	75			1×40							95					9 130					14 100	4 700	282	
CRWU 80-165R	2.3					165	105			2×40							135					10 300					16 500	5 480	329	
CRWU 80-205R	2.9					205	135			3×40							175					12 500					21 200	7 050	423	
CRWU 80-245R	3.5					245	155			4×40							215					14 700					25 900	8 620	517	
CRWU 80-285R	4.0					285	185			5×40							255					16 700					30 600	10 200	611	
CRWU 80-325R	4.6					325	215			6×40							295					18 700					35 300	11 800	705	
CRWU 100-110R*	2.4					100	±0.15			31							±0.1					110					60	50	25	—
CRWU 100-160R*	3.6	160	95	1×50	120			16 600	23 100		7 690	519																		
CRWU 100-210R*	4.7	210	130	2×50	170			21 600	32 300		10 800	727																		
CRWU 100-260R*	5.9	260	165	3×50	220			26 300	41 500		13 800	934																		
CRWU 100-310R*	7.0	310	200	4×50	270			30 800	50 700		16 900	1 140																		
CRWU 100-360R*	8.1	360	235	5×50	320			35 100	60 000		20 000	1 350																		
CRWU 100-410R*	9.3	410	265	6×50	370			37 200	64 600		21 500	1 450																		
CRWU 145-210R*	9.4	145	±0.2	42.5	±0.1			210	130		85	30	—	105	M8	43		21	46	49.5	1×100	55	M8	5	+0.020 0	150	30			68.4
CRWU 145-310R*	13.9					310	180	1×100	250	61 200			92 300				30 800				3 320									
CRWU 145-410R*	18.4					410	350	2×100	350	67 900			106 000				35 200				3 800									
CRWU 145-510R*	23.0					510	450	3×100	450	74 400			119 000				39 600				4 270									
CRWU 145-610R*	27.5					610	550	4×100	550	87 100			145 000				48 400				5 220									
CRWU 145-710R*	32.0					710	650	5×100	650	99 200			172 000				57 200				6 170									
CRWU 145-810R*	36.6					810	750	6×100	750	111 000			198 000				66 000				7 120									

Remark: The identification numbers with * are our semi-standard items.

CRW(G)(...H)
CRW(G)

IKO Crossed Roller Way Unit

Shape	CRWU...RS		
Size	20	30	40



Identification number	Mass (Ref.) kg	Nominal dimensions and tolerances mm						Table mounting dimensions mm						Center way mounting dimensions mm						Basic dynamic load rating C N	Basic static load rating C_0 N	Allowable load F N	Static moment rating T_0 N · m	
		W	Dim. W tolerance	H	Dim. H tolerance	L	Maximum stroke length	W_3	W_4	$N \times P$	E	M	H_1	t_1	W_1	W_2	$N_1 \times P_1$	E_1	M_1					t_2
CRWU 20- 25RS	0.03	20	± 0.1	8	± 0.1	25	12	14	3	1 × 18	3.5	M2.5	7.5	3.5	7	6.5	2 × 7.5	5	M2.5	4	380	478	159	1.8
CRWU 20- 35RS	0.05					35	18			1 × 28							2 × 10	7.5			525	717	239	2.8
CRWU 20- 45RS	0.06					45	25			1 × 20	3 × 10						659				956	319	3.7	
CRWU 20- 55RS	0.07					55	32			1 × 30	4 × 10						786	1 200			398	4.6		
CRWU 30- 65RS	0.20	30	± 0.1	12	± 0.1	65	40	22	4	1 × 30	17.5	M3	11.5	5.5	12	9	3 × 15	10	M3	6	1 850	2 940	979	19.1
CRWU 30- 80RS	0.24					80	50			1 × 45							4 × 15				2 130	3 530	1 180	22.9
CRWU 30- 95RS	0.29					95	60			2 × 30							5 × 15				2 410	4 110	1 370	26.7
CRWU 40-105RS	0.58	40	± 0.1	16	± 0.1	105	60	30	5	1 × 50	27.5	M4	15.5	7.5	16	12	3 × 25	15	M4	8	4 680	7 310	2 440	63.6
CRWU 40-130RS	0.72					130	75			1 × 75							4 × 25				5 860	9 750	3 250	84.8
CRWU 40-155RS	0.85					155	90			2 × 50							5 × 25				6 970	12 200	4 060	106

CRW(G)(...H)
CRW(G)