

# Metal Disc Couplings

# SERVOFLEX



Max. rated torque [N·m]	8000
Bore ranges [mm]	φ 3 ~ 115
Operating temperature range[*C]	-30 ~ 120(100)
Drive	Servomotor/stepper motor
Applications	Machine tool / semiconductor manufacturing equipment / printing press / packing machine

## High-stiffness and Low-inertia Servomotor Couplings

Metal disc couplings developed for high-speed and high-precision positioning and ultra-precise control of servomotors, etc. While achieving high stiffness, high torque, low inertia, and high response speed, these couplings are also flexible in the torsional direction, in the uneven directions, and in the shaft direction, and are totally free from backlash. Models with various characteristics are available, and each model has a single element type that emphasizes stiffness and a double element type that emphasizes flexibility.



## COUPLINGS

- ETP BUSHINGS
- ELECTROMAGNETIC CLUTCHES & BRAKES
- SPEED CHANGERS & REDUCERS
- INVERTERS
- LINEAR SHAFT DRIVES
- TORQUE LIMITERS
- ROSTA

## SERIES

- Metal Disc Couplings**  
SERVOFLEX
- High-rigidity Couplings  
SERVORIGID
- Metal Slit Couplings  
HELI-CAL
- Metal Coil Spring Couplings  
BAUMANNFLEX
- Pin Bushing Couplings  
PARAFLEX
- Link Couplings  
SCHMIDT
- Dual Rubber Couplings  
STEPFLEX
- Jaw Couplings  
MIKI PULLEY  
STARFLEX
- Jaw Couplings  
SPRFLEX
- Plastic Bellows Couplings  
BELLOWFLEX
- Rubber and Plastic Couplings  
CENTAFLEX

## MODELS

- SFC
- SFS
- SFF
- SFM
- SFH

## Available Models

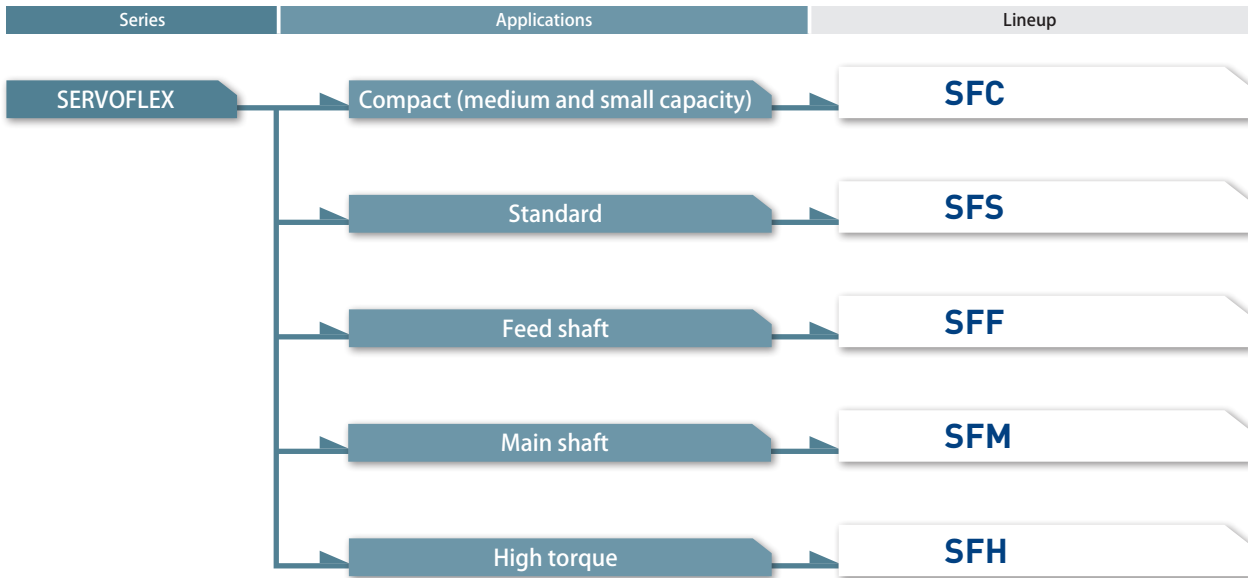

## Model Selection

Model type	Rated torque [N · m]						High stiffness	Low inertia	Mountability	Mounting accuracy	High-speed rotation	Material	Operating temperature [°C]
	0.1	1	10	100	1000	10000							
SFC	0.25 ~ 250						◎	●	●	◎	◎	Aluminum alloy	-30 ~ 100
SFS	20 ~ 800						◎	◎	△	○	○	Steel	-30 ~ 120
SFF	8 ~ 1000						●	●	◎	●	●	Steel	-30 ~ 120
SFM	60 ~ 1000						●	◎	○	●	●	Steel	-30 ~ 120
SFH	1000 ~ 8000						●	◎	△	○	○	Steel	-30 ~ 120

\* Symbols in the table indicate four levels of adaptability in order of ●◎○△ with ● showing the highest level of adaptability and △ showing the lowest level. (Adaptability high ←●◎○△→ low)

**Product Lineup**

**SFC**



Applications: NC lathe, machining center, chip mounter, actuator, SCARA robot, semiconductor manufacturing equipment

Max. rated torque	[N·m]	250
Bore ranges	[mm]	φ 3 ~ 45

**High Stiffness and Ultra-low Inertia**

Small- and medium-capacity model, which is made of a high-strength aluminum alloy and whose outer hub diameter is linked to the shaft diameter to achieve a ultra-low inertia ideal for high-speed rotation. Three different shapes are available depending on the combination of bore diameters you use.



**SFC SA2**

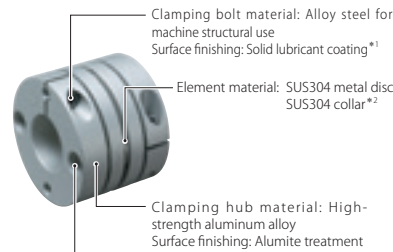

Bolt material: Alloy steel for machine structural use  
Surface finishing: Trivalent chromate treatment\*3

**SFC DA2**

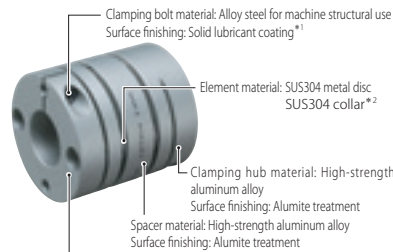

Bolt material: Alloy steel for machine structural use  
Surface finishing: Trivalent chromate treatment\*3

**SFC SA2/DA2 BC**

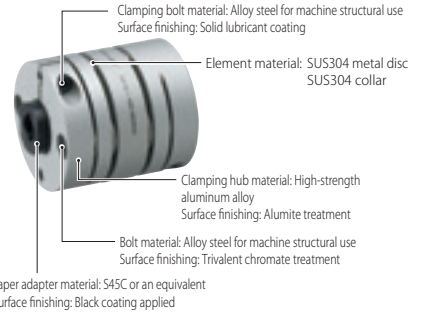

Taper adapter material: S45C or an equivalent  
Surface finishing: Black coating applied

- \* 1 For surface processing of the clamping bolts, black coating is applied only for #002.
- \* 2 The collar material in the marked area is S45C in sizes #080 to #100, and the surface finishing is trivalent chrome treatment.
- \* 3 The bolt surface finishing in the marked area is anti-rust coating in sizes #080 to #100.

**Simple and Reliable Connection**

A single clamping method is used for connection to the shaft. The clamping hub is shock and vibration proof, enabling reliable connection and helping to substantially reduce mounting time. A special jig is used for centering to achieve an extremely high concentricity.

**Wide Variety of Options**

A wide variety of options such as a tapered shaft, length-specified special order, and keyway milling application are available. You can combine options to meet your desired specifications.

**SFS**

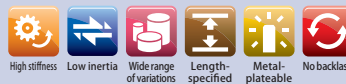

Applications: Machine tool, printing press, packing machine, coater/coating machine

Max. rated torque	[N·m]	800
Bore ranges	[mm]	φ 8 ~ 60

**Wide Variations**

SERVOFLEX standard model. 18 types with different numbers of elements, distances between shafts, shaft connection methods, etc. are available. You can select the electroless nickel plating for the pilot bore and key/set screw.

**Parts Delivery**

You can order the parts of the coupling to be delivered instead of an assembled coupling, so you can use this coupling in a design in which the assembled coupling could not be mounted. You can also order an assembled coupling to be delivered or combine different types of hubs.

**SFS S**

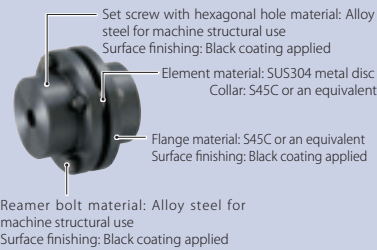

**SFS S-C**

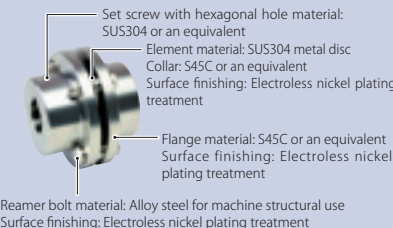

**SFS S-□M-□M**

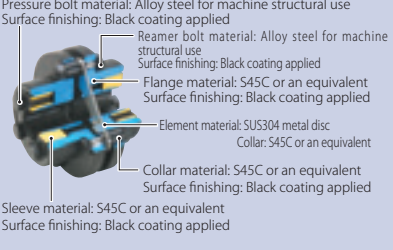

**SFS W**

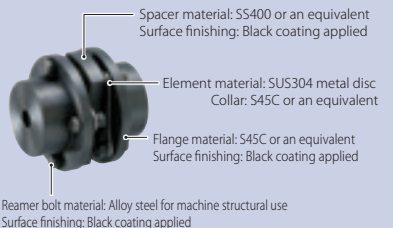

**SFS S-□M-□C**

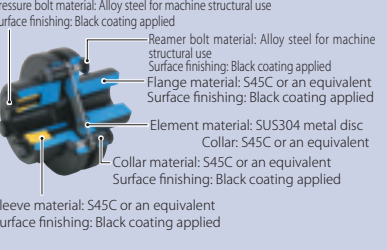

**SFS G**

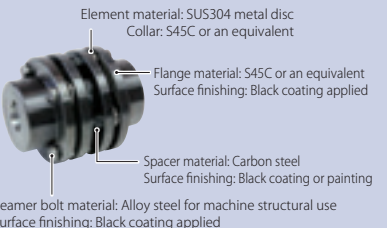

COUPLINGS

ETP BUSHINGS

ELECTROMAGNETIC CLUTCHES & BRAKES

SPEED CHANGERS & REDUCERS

INVERTERS

LINEAR SHAFT DRIVES

TORQUE LIMITERS

ROSTA

SERIES

Metal Disc Couplings	<b>SERVOFLEX</b>
	High-rigidity Couplings <b>SERVORIGID</b>
	Metal Slit Couplings <b>HELI-CAL</b>
	Metal Coil Spring Couplings <b>BAUMANNFLEX</b>
	Pin Bushing Couplings <b>PARAFLEX</b>
Link Couplings	<b>SCHMIDT</b>
	Dual Rubber Couplings <b>STEPFLEX</b>
	Jaw Couplings <b>MIKI PULLEY STARFLEX</b>
	Jaw Couplings <b>SPRFLEX</b>
	Plastic Bellows Couplings <b>BELLOWFLEX</b>
Rubber and Plastic Couplings	Rubber and Plastic Couplings <b>CENTAFLEX</b>

# SFF

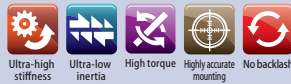

Applications: NC lathe, machining center, chip moulder, electrical discharge machine

Max. rated torque	[N · m]	1000
Bore ranges	[mm]	φ 8 ~ 80

## Ultra-high Stiffness and Ultra-low Inertia

Ultrahigh torsional stiffness, achieving 1.5 times the rated torque of the current model and low inertia.

### SFF SS

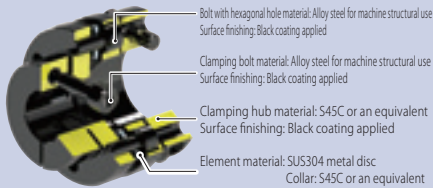

## High-precision Clamping Connection

The number of mounting bolts has been reduced substantially. You can remarkably reduce mounting time.

## Frictional Coupling for Large Diameters

This model supports frictional coupling for larger-diameter shafts than the previous models.

### Tapered shaft hub

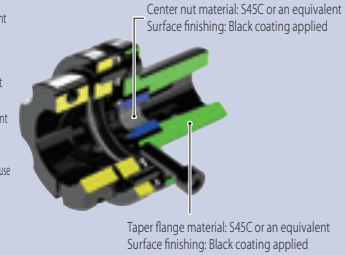
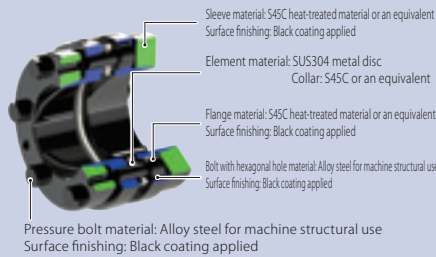

### SFF DS

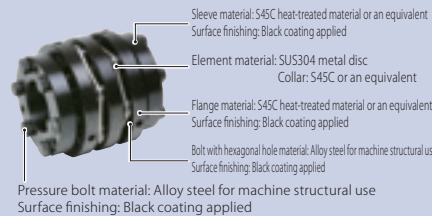

### Clamping hub + wedge coupling hub

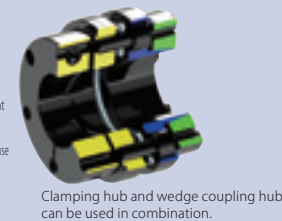

# SFM



Application: Machine tool main shaft

Max. rated torque	[N · m]	1000
Bore ranges	[mm]	φ 12 ~ 80

## As Machine Tool Main Shaft

Hi-spec model for meeting the high-torque, low-inertia, and high-revolution demands of machine tool main shafts.

## Max. Rotation Speed 24000 min<sup>-1</sup>

High-speed design, balance corrected.

### SFM SS

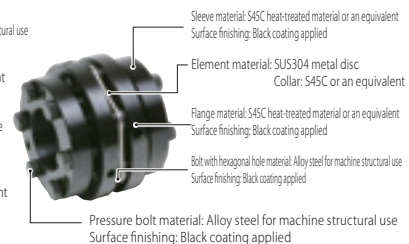

# SFH



Applications: Double column machining center, printing press, testing machinery, wind turbine generator

Max. rated torque	[N · m]	8000
Bore ranges	[mm]	φ 22 ~ 115

## Max. Rated Torque 8000N·m

This model was developed to transmit a large torque, has an extremely high torsional stiffness, and enables precise shaft rotation and ultra-precise control.

## Total Length Can Be Specified

The total length can be specified for a type that connects the middle of the element using a floating shaft.

### SFH S



### SFH G-□K-□K

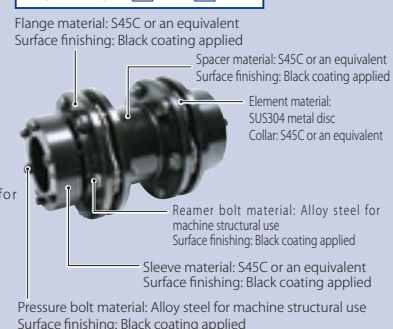

MODELS

SFC

SFS

SFF

SFM

SFH

## Customization Cases

### SFC Model stainless steel

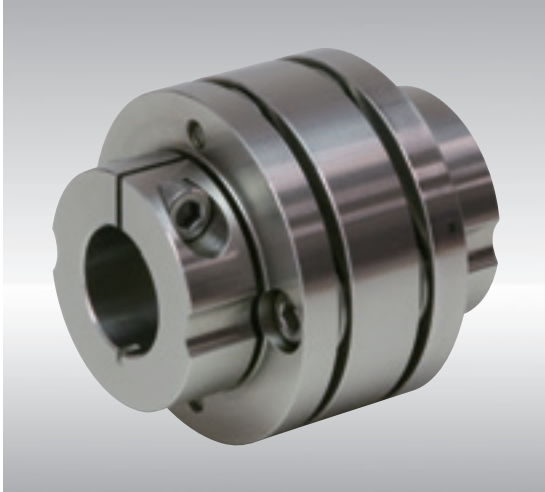

The all-stainless-steel construction provides even better rust-proofing.

### SFC Model with slit plate



A slit plate is mounted between the hubs to allow it to be used with position detection sensors such as an encoder and photo sensor.

### SFC Model with long spacer

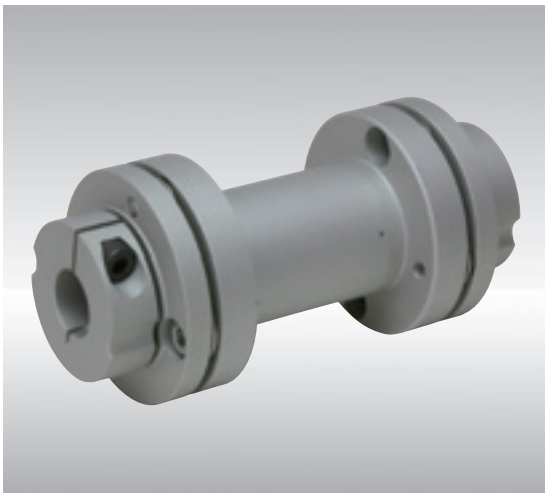

This is a specification for when the mounting distance between shafts is long. It can be used in applications such as synchronization of gantry mechanism.

### SFF Model For non-excitation brake assemblies



The device design can be made more compact by forming the spline to the outer diameter of the SFF model and using it as the rotor hub for a Miki Pulley non-excitation brake.

For details, please visit our website.

FAQ

**Q1 What are the durability and aging deterioration of the SERVOFLEX?**

**A** We conduct a torsional durability test by applying a load larger than the rated torque. SERVOFLEX passed the test by withstanding the metal fatigue limit of 10 million cycles of repeated load. SERVOFLEX is all made of metal materials so the deterioration is extremely slow, and it is able to transmit torque with high precision for a long period of time.

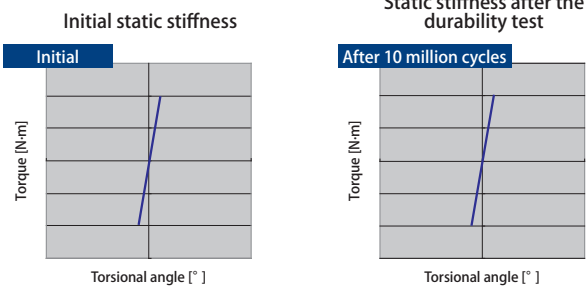

Torsional characteristics of the SERVOFLEX before and after the durability test with 10 million cycles of repeated load

**Q2 When a coupling is mounted, the driven shaft runs out. What is the cause?**

**A** The runout of a driven shaft caused by a coupling is mainly attributed to the counterforce of the shaft caused by insufficient centering. All of the SERVOFLEX series are assembled using high-precision special jigs to ensure high concentricity of the bores on the left and right. The counterforce of the shaft is extremely small so the runout of the driven shaft can be minimized.

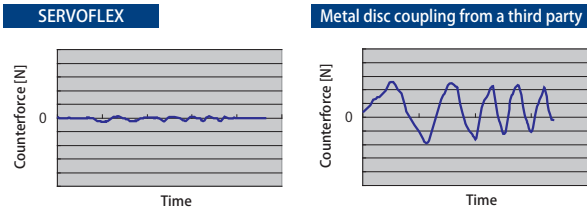

**Q3 Noise and vibrations occurred during use of a metal disc coupling. Please tell me how to prevent them.**

**A** For a servo motor, noise and vibrations can be suppressed by setting the machine resonance suppression filter to its natural frequency in the control system. For a stepper motor, vibrations can be absorbed and suppressed by changing the rotation speed or using a STEPFLEX coupling with high damping ability.

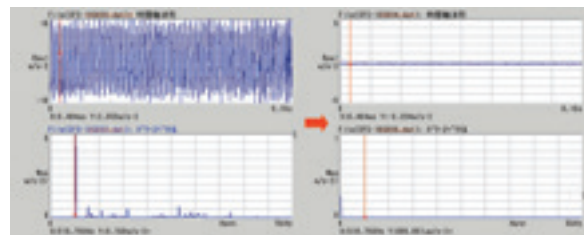

Before adjusting the resonant filter of the servo motor      After adjusting the resonant filter of the servo motor

**Q4 Can enough torque be transmitted using the clamping method for connection to the shaft?**

**A** Our torque transmission test uses a sufficient safety factor, so slip of the connection caused by the connection method will not occur when using the rated torque in the catalog. A keyway can be milled into the clamping hub. If you are interested, please refer to P.043 Keyway Milling Option.

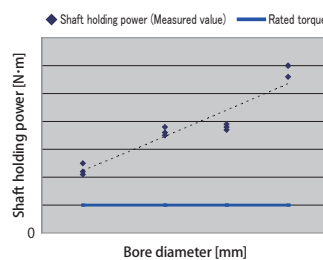

Shaft holding power based on SFC-040DA2 bore diameter

COUPLINGS

ETP BUSHINGS

ELECTROMAGNETIC CLUTCHES & BRAKES  
SPEED CHANGERS & REDUCERS

INVERTERS

LINEAR SHAFT DRIVES

TORQUE LIMITERS

ROSTA

SERIES

Metal Disc Couplings	Metal Disc Couplings <b>SERVOFLEX</b>
	High-rigidity Couplings <b>SERVORIGID</b>
	Metal Slit Couplings <b>HELI-CAL</b>
Metal Couplings	Metal Coil Spring Couplings <b>BAUMANNFLEX</b>
	Pin Bushing Couplings <b>PARAFLEX</b>
	Link Couplings <b>SCHMIDT</b>
Rubber and Plastic Couplings	Dual Rubber Couplings <b>STEPFLEX</b>
	Jaw Couplings <b>MIKI PULLEY STARFLEX</b>
	Jaw Couplings <b>SPRFLEX</b>
	Plastic Bellows Couplings <b>BELLOWFLEX</b>
	Rubber and Plastic Couplings <b>CENTAFLEX</b>

MODELS

SFC

SFS

SFF

SFM

SFH

# SFC SA2 Types Single Element Type

## Specifications

Model	Type	Rated torque [N·m]	Misalignment			Max. rotation speed [min <sup>-1</sup> ]	Torsional stiffness [N·m/rad]	Axial stiffness [N/mm]	Moment of inertia [kg·m <sup>2</sup> ]	Mass [kg]
			Parallel [mm]	Angular [°]	Axial [mm]					
SFC-002SA2	C	0.25	0.01	0.5	±0.04	10000	190	34	0.06 × 10 <sup>-6</sup>	0.003
SFC-005SA2	C	0.6	0.02	0.5	±0.05	10000	500	140	0.26 × 10 <sup>-6</sup>	0.007
SFC-010SA2	C	1	0.02	1	±0.1	10000	1400	140	0.58 × 10 <sup>-6</sup>	0.011
SFC-020SA2	C	2	0.02	1	±0.15	10000	3700	64	2.39 × 10 <sup>-6</sup>	0.025
SFC-025SA2	C	4	0.02	1	±0.19	10000	5600	60	3.67 × 10 <sup>-6</sup>	0.029
SFC-030SA2	A	5	0.02	1	±0.2	10000	8000	64	4.07 × 10 <sup>-6</sup>	0.034
	B	5	0.02	1	±0.2	10000	8000	64	6.09 × 10 <sup>-6</sup>	0.041
	C	5	0.02	1	±0.2	10000	8000	64	8.20 × 10 <sup>-6</sup>	0.049
SFC-035SA2	C	10	0.02	1	±0.25	10000	18000	112	18.44 × 10 <sup>-6</sup>	0.082
SFC-040SA2	A	12	0.02	1	±0.3	10000	20000	80	16.71 × 10 <sup>-6</sup>	0.077
	B	12	0.02	1	±0.3	10000	20000	80	22.55 × 10 <sup>-6</sup>	0.085
	C	12	0.02	1	±0.3	10000	20000	80	29.25 × 10 <sup>-6</sup>	0.100
SFC-050SA2	A	25	0.02	1	±0.4	10000	32000	48	55.71 × 10 <sup>-6</sup>	0.159
	B	25	0.02	1	±0.4	10000	32000	48	76.26 × 10 <sup>-6</sup>	0.177
	C	25	0.02	1	±0.4	10000	32000	48	99.03 × 10 <sup>-6</sup>	0.206
SFC-055SA2	C	40	0.02	1	±0.42	10000	50000	43	188.0 × 10 <sup>-6</sup>	0.314
SFC-060SA2	A	60	0.02	1	±0.45	10000	70000	76.4	145.9 × 10 <sup>-6</sup>	0.283
	B	60	0.02	1	±0.45	10000	70000	76.4	205.0 × 10 <sup>-6</sup>	0.326
SFC-060SA2	C	60	0.02	1	±0.45	10000	70000	76.4	268.6 × 10 <sup>-6</sup>	0.385
	C	60	0.02	1	±0.45	10000	70000	76.4	268.6 × 10 <sup>-6</sup>	0.385
SFC-080SA2	C	100	0.02	1	±0.55	10000	140000	128	710.6 × 10 <sup>-6</sup>	0.708
SFC-090SA2	C	180	0.02	1	±0.65	10000	100000	108	1236 × 10 <sup>-6</sup>	0.946
SFC-100SA2	C	250	0.02	1	±0.74	10000	120000	111	1891 × 10 <sup>-6</sup>	1.202

\* Check the Standard Bore Diameter list as rated torque may be restricted by the holding power of the shaft connection component.

\* Max. rotation speed does not take into account dynamic balance.

\* Torsional stiffness values given are measured values for the element alone.

\* The moment of inertia and mass are measured for the maximum bore diameter.

## Dimensions

■ TYPE A

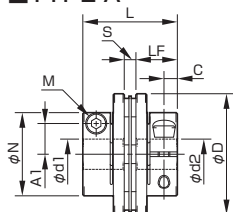

■ TYPE B

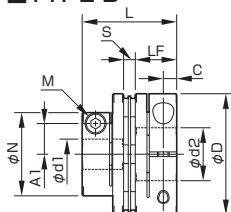

■ TYPE C

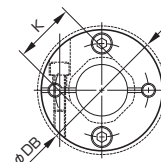
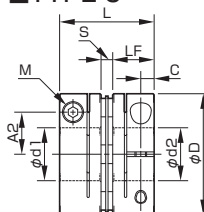

Model	Type	d1 [mm]		d2 [mm]		D [mm]	DB [mm]	N [mm]	L [mm]	LF [mm]	S [mm]	A1 [mm]	A2 [mm]	C [mm]	K [mm]	M Qty - Nominal dia.	Tightening torque [N·m]
		Min.	Max.	Min.	Max.												
SFC-002SA2	C	3	5	3	5	12	12.4	—	12.35	5.9	0.55	—	3.7	1.9	5.6	1-M1.6	0.23 ~ 0.28
SFC-005SA2	C	3	6	3	6	16	—	—	16.7	7.85	1	—	4.8	2.5	6.5	1-M2	0.4 ~ 0.5
SFC-010SA2	C	3	8	3	8	19	—	—	19.35	9.15	1.05	—	5.8(6)	3.15	8.5	1-M2.5(M2)	1.0 ~ 1.1(1.04 ~ 0.5)
SFC-020SA2	C	4	10	4	11	26	—	—	23.15	10.75	1.65	—	9.5	3.3	10.6	1-M2.5	1.0 ~ 1.1
SFC-025SA2	C	5	14	5	14	29	—	—	23.4	10.75	1.9	—	11	3.3	14.5	1-M2.5	1.0 ~ 1.1
SFC-030SA2	A	5	10	5	10	34	—	21.6	27.3	12.4	2.5	8	—	3.75	14.5	1-M3	1.5 ~ 1.9
	B	5	10	Over 10	16	34	—	21.6	27.3	12.4	2.5	8	12.5	3.75	14.5	1-M3	1.5 ~ 1.9
	C	Over 10	14	Over 10	16	34	—	—	27.3	12.4	2.5	—	12.5	3.75	14.5	1-M3	1.5 ~ 1.9
SFC-035SA2	C	6	16	6	19	39	—	—	34	15.5	3	—	14	4.5	17	1-M4	3.4 ~ 4.1
SFC-040SA2	A	8	15	8	15	44	—	29.6	34	15.5	3	11	—	4.5	19.5	1-M4	3.4 ~ 4.1
	B	8	15	Over 15	24	44	—	29.6	34	15.5	3	11	17	4.5	19.5	1-M4	3.4 ~ 4.1
	C	Over 15	19	Over 15	24	44	—	—	34	15.5	3	—	17	4.5	19.5	1-M4	3.4 ~ 4.1
SFC-050SA2	A	8	19	8	19	56	—	38	43.4	20.5	2.4	14.5	—	6	26	1-M5	7.0 ~ 8.5
	B	8	19	Over 19	30	56	—	38	43.4	20.5	2.4	14.5	22	6	26	1-M5	7.0 ~ 8.5
SFC-055SA2	C	Over 19	25	Over 19	30	56	—	—	43.4	20.5	2.4	—	22	6	26	1-M5	7.0 ~ 8.5
	C	10	30	10	30	63	—	—	50.6	24	2.6	—	23	7.75	31	1-M6	14 ~ 15
SFC-060SA2	A	11	24	11	24	68	—	46	53.6	25.2	3.2	17.5	—	7.75	31	1-M6	14 ~ 15
	B	11	24	Over 24	35	68	—	46	53.6	25.2	3.2	17.5	26.5	7.75	31	1-M6	14 ~ 15
SFC-060SA2	C	Over 24	30	Over 24	35	68	—	—	53.6	25.2	3.2	—	26.5	7.75	31	1-M6	14 ~ 15
	C	18	35	18	40	82	—	—	68	30	8	—	28	9	38	1-M8	27 ~ 30
SFC-090SA2	C	25	40	25	45	94	—	—	68.3	30	8.3	—	34	9	42	1-M8	27 ~ 30
SFC-100SA2	C	32	45	32	45	104	—	—	69.8	30	9.8	—	39	9	48	1-M8	27 ~ 30

\* The φDB value is measured assuming that the head of the clamping bolt is larger than the external diameter of the hub.

\* The K dimension is the inner diameter of the element. For d2 dimension exceeding this value, shaft can be inserted only up to LF dimension to the d2 side hub.

\* The nominal diameter for the clamping bolt M is equal to the quantity minus the nominal diameter of the screw threads, where the quantity is for a hub on one side.

\* The figures in parentheses ( ) for the SFC-010 are the values when d1 or d2 is ø8 mm.

## COUPLINGS

ETP BUSHINGS

ELECTROMAGNETIC CLUTCHES & BRAKES

SPEED CHANGERS & REDUCERS

INVERTERS

LINEAR SHAFT DRIVES

TORQUE LIMITERS

ROSTA

## SERIES

Metal Disc Couplings  
**SERVOFLEX**

High-rigidity Couplings  
SERVORIGID

Metal Slit Couplings  
HELI-CAL

Metal Coil Spring Couplings  
BAUMANNFLEX

Pin Bushing Couplings  
PARAFLEX

Link Couplings  
SCHMIDT

Dual Rubber Couplings  
STEPFLEX

Jaw Couplings  
MIKI PULLEY STARFLEX

Jaw Couplings  
SPRFLEX

Plastic Bellows Couplings  
BELLOWFLEX

Rubber and Plastic Couplings  
CENTAFLEX

## MODELS

SFC

SFS

SFF

SFM

SFH

## Standard Bore Diameter

		Standard (option) bore diameter, d1/d2 [mm] and restricted rated torque [N-m]																																	
Nominal bore diameter		3	4	5	6	6.35	7	8	9	9.525	10	11	12	13	14	15	16	17	18	19	20	22	24	25	28	30	32	35	38	40	42	45			
Shaft tolerance	h7 (h6 + g6)	B	●	●	●	●	●	●	●	●	●	●	●	●	●	●	●	●	●	●	●	●	●	●	●	●	●	●	●	●	●	●			
	j6(option)	J																			○	○	○	○	○										
	k6(option)	K							○	○								○			○	○	○					○	○						
Supported bore diameter for each model	SFC-002SA2	d1	●	●	●																														
		d2	●	●	●																														
	SFC-005SA2	d1	●	●	●	●																													
		d2	●	●	●	●																													
	SFC-010SA2	d1	●	●	●	●	●	●																											
		d2	●	●	●	●	●	●																											
	SFC-020SA2	d1	●	●	●	●	●	●	●	●																									
		d2	●	●	●	●	●	●	●	●	●																								
	SFC-025SA2	d1				2.1	●	●	●	●	●	●	●	●	●	●	●	●	●	●	●	●	●	●	●	●	●	●	●	●	●	●	●	●	
		d2				2.1	●	●	●	●	●	●	●	●	●	●	●	●	●	●	●	●	●	●	●	●	●	●	●	●	●	●	●	●	
	SFC-030SA2	d1				2.8	3.4	●	●	●	●	●	●	●	●	●	●	●	●	●	●	●	●	●	●	●	●	●	●	●	●	●	●	●	
		d2				2.8	3.4	●	●	●	●	●	●	●	●	●	●	●	●	●	●	●	●	●	●	●	●	●	●	●	●	●	●	●	
	SFC-035SA2	d1				5	5	6.6	●	●	●	●	●	●	●	●	●	●	●	●	●	●	●	●	●	●	●	●	●	●	●	●	●	●	
		d2				5	5	6.6	●	●	●	●	●	●	●	●	●	●	●	●	●	●	●	●	●	●	●	●	●	●	●	●	●	●	
	SFC-040SA2	d1							9	●	●	●	●	●	●	●	●	●	●	●	●	●	●	●	●	●	●	●	●	●	●	●	●	●	
		d2							9	●	●	●	●	●	●	●	●	●	●	●	●	●	●	●	●	●	●	●	●	●	●	●	●	●	●
	SFC-050SA2	d1									18	20	22	22	●	●	●	●	●	●	●	●	●	●	●	●	●	●	●	●	●	●	●	●	
		d2									18	20	22	22	●	●	●	●	●	●	●	●	●	●	●	●	●	●	●	●	●	●	●	●	
SFC-055SA2	d1												31	34	36	38	●	●	●	●	●	●	●	●	●	●	●	●	●	●	●	●	●		
	d2												31	34	36	38	●	●	●	●	●	●	●	●	●	●	●	●	●	●	●	●	●		
SFC-060SA2	d1													50	51	●	●	●	●	●	●	●	●	●	●	●	●	●	●	●	●	●			
	d2													50	51	●	●	●	●	●	●	●	●	●	●	●	●	●	●	●	●	●			
SFC-080SA2	d1																																		
	d2																																		
SFC-090SA2	d1																																		
	d2																																		
SFC-100SA2	d1																																		
	d2																																		

\* The shaft tolerance for standard bore diameter is h7 (h6 or g6): designation B. However, for a shaft diameter of ø35, the tolerance is  $\pm \frac{0.010}{0.025}$ .

\* Shaft tolerances j6/k6: designations J/K are optional, and are only supported for bore diameters marked with ○.

\* Bore diameters marked with ● or numbers are supported as the standard bore diameters. Consult Miki Pulley regarding special arrangements which may be possible for other bore diameters.

\* Bore diameters whose fields contain numbers are restricted in their rated torque by the holding power of the shaft connection component because the bore diameter is small. The numbers indicate the rated torque [N-m].

### How to Place an Order

### SFC-025SA2-10B-14K

Size ————  
 Type ————  
 SA2: Single element  
 Aluminum alloy hub  
 Bore diameter d1 (Small diameter) ————  
 Bore diameter d2 (Large diameter) ————

Supported shaft tolerance  
 B: h7(h6, g6) shaft  
 J: j6 shaft (option)  
 K: k6 shaft (option)

\* For nominal bore diameter, select d1 (small diameter)-d2 (large diameter) in that order.

\* If d1=d2 (same diameters), select B, J, and K in that order.



# SFC DA2 Types Double Element Type

## Specifications

Model	Type	Rated torque [N·m]	Misalignment			Max. rotation speed [min <sup>-1</sup> ]	Torsional stiffness [N·m/rad]	Axial stiffness [N/mm]	Moment of inertia [kg·m <sup>2</sup> ]	Mass [kg]
			Parallel [mm]	Angular [°]	Axial [mm]					
SFC-002DA2	C	0.25	0.03	0.5(On one side)	± 0.08	10000	95	17	0.07 × 10 <sup>-6</sup>	0.004
SFC-005DA2	C	0.6	0.05	0.5(On one side)	± 0.1	10000	250	70	0.37 × 10 <sup>-6</sup>	0.010
SFC-010DA2	C	1	0.11	1(On one side)	± 0.2	10000	700	70	0.80 × 10 <sup>-6</sup>	0.015
SFC-020DA2	C	2	0.15	1(On one side)	± 0.33	10000	1850	32	3.43 × 10 <sup>-6</sup>	0.035
SFC-025DA2	C	4	0.16	1(On one side)	± 0.38	10000	2800	30	5.26 × 10 <sup>-6</sup>	0.040
SFC-030DA2	A	5	0.18	1(On one side)	± 0.4	10000	4000	32	7.43 × 10 <sup>-6</sup>	0.054
	B	5	0.18	1(On one side)	± 0.4	10000	4000	32	9.45 × 10 <sup>-6</sup>	0.060
	C	5	0.18	1(On one side)	± 0.4	10000	4000	32	11.56 × 10 <sup>-6</sup>	0.068
SFC-035DA2	C	10	0.24	1(On one side)	± 0.5	10000	9000	56	26.93 × 10 <sup>-6</sup>	0.121
SFC-040DA2	A	12	0.24	1(On one side)	± 0.6	10000	10000	40	29.98 × 10 <sup>-6</sup>	0.124
	B	12	0.24	1(On one side)	± 0.6	10000	10000	40	35.82 × 10 <sup>-6</sup>	0.131
	C	12	0.24	1(On one side)	± 0.6	10000	10000	40	42.52 × 10 <sup>-6</sup>	0.146
SFC-050DA2	A	25	0.28	1(On one side)	± 0.8	10000	16000	24	98.34 × 10 <sup>-6</sup>	0.250
	B	25	0.28	1(On one side)	± 0.8	10000	16000	24	118.9 × 10 <sup>-6</sup>	0.268
	C	25	0.28	1(On one side)	± 0.8	10000	16000	24	141.7 × 10 <sup>-6</sup>	0.298
SFC-055DA2	C	40	0.31	1(On one side)	± 0.84	10000	25000	21.5	261.3 × 10 <sup>-6</sup>	0.459
SFC-060DA2	A	60	0.34	1(On one side)	± 0.9	10000	35000	38.2	256.6 × 10 <sup>-6</sup>	0.447
	B	60	0.34	1(On one side)	± 0.9	10000	35000	38.2	315.7 × 10 <sup>-6</sup>	0.489
SFC-080DA2	A	60	0.34	1(On one side)	± 0.9	10000	35000	38.2	379.3 × 10 <sup>-6</sup>	0.549
	C	60	0.34	1(On one side)	± 0.9	10000	35000	38.2	379.3 × 10 <sup>-6</sup>	0.549
SFC-080DA2	C	100	0.52	1(On one side)	± 1.10	10000	70000	64	1039 × 10 <sup>-6</sup>	1.037
SFC-090DA2	C	180	0.52	1(On one side)	± 1.30	10000	50000	54	1798 × 10 <sup>-6</sup>	1.369
SFC-100DA2	C	250	0.55	1(On one side)	± 1.48	10000	60000	55.5	2754 × 10 <sup>-6</sup>	1.739

\* Check the "Standard Bore Diameters" as rated torque may be restricted by the holding power of the shaft connection component.

\* Max. rotation speed does not take into account dynamic balance.

\* Torsional stiffness values given are measured values for the element alone.

\* The moment of inertia and mass are measured for the maximum bore diameter.

## Dimensions

■ TYPE A

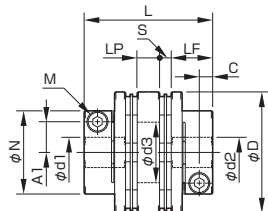

■ TYPE B

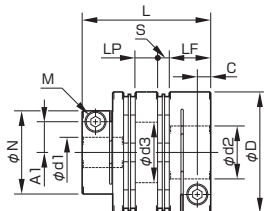

■ TYPE C

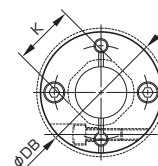
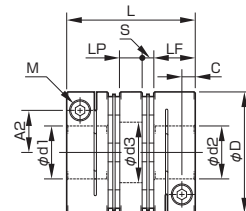

Model	Type	d1 [mm]		d2 [mm]		D [mm]	DB [mm]	N [mm]	L [mm]	LF [mm]	LP [mm]	S [mm]	A1 [mm]	A2 [mm]	C [mm]	d3 [mm]	K [mm]	M Qty - Nominal dia.	Tightening torque [N·m]
		Min.	Max.	Min.	Max.														
SFC-002DA2	C	3	5	3	5	12	12.4	—	15.7	5.9	2.8	0.55	—	3.7	1.9	5.2	5.6	1-M1.6	0.23 ~ 0.28
SFC-005DA2	C	3	6	3	6	16	—	—	23.2	7.85	5.5	1	—	4.8	2.5	6.5	6.5	1-M2	0.4 ~ 0.5
SFC-010DA2	C	3	8	3	8	19	—	—	25.9	9.15	5.5	1.05	—	5.8(6)	3.15	8.5	8.5	1-M2.5(M2)	1.0 ~ 1.1(0.4 ~ 0.5)
SFC-020DA2	C	4	10	4	11	26	—	—	32.3	10.75	7.5	1.65	—	9.5	3.3	10.6	10.6	1-M2.5	1.0 ~ 1.1
SFC-025DA2	C	5	14	5	14	29	—	—	32.8	10.75	7.5	1.9	—	11	3.3	15	14.5	1-M2.5	1.0 ~ 1.1
SFC-030DA2	A	5	10	5	10	34	—	21.6	37.8	12.4	8	2.5	8	—	3.75	15	14.5	1-M3	1.5 ~ 1.9
	B	5	10	Over 10	16	34	—	21.6	37.8	12.4	8	2.5	8	12.5	3.75	15	14.5	1-M3	1.5 ~ 1.9
SFC-030DA2	C	Over 10	14	Over 10	16	34	—	—	37.8	12.4	8	2.5	—	12.5	3.75	15	14.5	1-M3	1.5 ~ 1.9
	C	Over 10	14	Over 10	16	34	—	—	37.8	12.4	8	2.5	—	12.5	3.75	15	14.5	1-M3	1.5 ~ 1.9
SFC-035DA2	C	6	16	6	19	39	—	—	48	15.5	11	3	—	14	4.5	17	17	1-M4	3.4 ~ 4.1
SFC-040DA2	A	8	15	8	15	44	—	29.6	48	15.5	11	3	11	—	4.5	20	19.5	1-M4	3.4 ~ 4.1
	B	8	15	Over 15	24	44	—	29.6	48	15.5	11	3	11	17	4.5	20	19.5	1-M4	3.4 ~ 4.1
SFC-040DA2	C	Over 15	19	Over 15	24	44	—	—	48	15.5	11	3	—	17	4.5	20	19.5	1-M4	3.4 ~ 4.1
	C	Over 15	19	Over 15	24	44	—	—	48	15.5	11	3	—	17	4.5	20	19.5	1-M4	3.4 ~ 4.1
SFC-050DA2	A	8	19	8	19	56	—	38	59.8	20.5	14	2.4	14.5	—	6	26	26	1-M5	7.0 ~ 8.5
	B	8	19	Over 19	30	56	—	38	59.8	20.5	14	2.4	14.5	22	6	26	26	1-M5	7.0 ~ 8.5
SFC-050DA2	C	Over 19	25	Over 19	30	56	—	—	59.8	20.5	14	2.4	—	22	6	26	26	1-M5	7.0 ~ 8.5
	C	Over 19	25	Over 19	30	56	—	—	59.8	20.5	14	2.4	—	22	6	26	26	1-M5	7.0 ~ 8.5
SFC-055DA2	C	10	30	10	30	63	—	—	68.7	24	15.5	2.6	—	23	7.75	31	31	1-M6	14 ~ 15
SFC-060DA2	A	11	24	11	24	68	—	46	73.3	25.2	16.5	3.2	17.5	—	7.75	31	31	1-M6	14 ~ 15
	B	11	24	Over 24	35	68	—	46	73.3	25.2	16.5	3.2	17.5	26.5	7.75	31	31	1-M6	14 ~ 15
SFC-060DA2	C	Over 24	30	Over 24	35	68	—	—	73.3	25.2	16.5	3.2	—	26.5	7.75	31	31	1-M6	14 ~ 15
	C	Over 24	30	Over 24	35	68	—	—	73.3	25.2	16.5	3.2	—	26.5	7.75	31	31	1-M6	14 ~ 15
SFC-080DA2	C	18	35	18	40	82	—	—	98	30	22	8	—	28	9	40	38	1-M8	27 ~ 30
SFC-090DA2	C	25	40	25	45	94	—	—	98.6	30	22	8.3	—	34	9	47	42	1-M8	27 ~ 30
SFC-100DA2	C	32	45	32	45	104	—	—	101.6	30	22	9.8	—	39	9	50	48	1-M8	27 ~ 30

\* The φdB value is measured assuming that the head of the clamping bolt is larger than the external diameter of the hub.

\* The K dimension is the inner diameter of the element. For d2 dimension exceeding this value, shaft can be inserted only up to LF dimension to the d2 side hub.

\* The nominal diameter for the clamping bolt M is equal to the quantity minus the nominal diameter of the screw threads, where the quantity is for a hub on one side.

\* The figures in parentheses ( ) for the SFC-010 are the values when d1 or d2 is ø8 mm.

COUPLINGS

ETP BUSHINGS

ELECTROMAGNETIC CLUTCHES & BRAKES

SPEED CHANGERS & REDUCERS

INVERTERS

LINEAR SHAFT DRIVES

TORQUE LIMITERS

ROSTA

SERIES

Metal Disc Couplings	<b>SERVOFLEX</b>
	High-rigidity Couplings <b>SERVORIGID</b>
	Metal Slit Couplings <b>HELI-CAL</b>
Metal Couplings	Metal Coil Spring Couplings <b>BAUMANNFLEX</b>
	Pin Bushing Couplings <b>PARAFLEX</b>
Link Couplings	<b>SCHMIDT</b>
	Dual Rubber Couplings <b>STEPFLEX</b>
Rubber and Plastic Couplings	Jaw Couplings <b>MIKI PULLEY STARFLEX</b>
	Jaw Couplings <b>SPRFLEX</b>
	Plastic Bellows Couplings <b>BELLOWFLEX</b>
Rubber and Plastic Couplings	Rubber and Plastic Couplings <b>CENTAFLEX</b>

MODELS

- SFC
- SFS
- SFF
- SFM
- SFH

Standard Bore Diameter

		Standard (option) bore diameter, d1/d2 [mm] and restricted rated torque [N-m]																														
Nominal bore diameter		3	4	5	6	6.35	7	8	9	9.525	10	11	12	13	14	15	16	17	18	19	20	22	24	25	28	30	32	35	38	40	42	45
Shaft tolerance	h7 (h6 + g6)	B	●	●	●	●	●	●	●	●	●	●	●	●	●	●	●	●	●	●	●	●	●	●	●	●	●	●	●	●	●	●
	j6(option)	J																			○	○	○	○	○							
	k6(option)	K							○	○								○			○	○	○				○	○				
Supported bore diameter for each model	SFC-002DA2	d1	●	●	●																											
		d2	●	●	●																											
	SFC-005DA2	d1	●	●	●	●																										
		d2	●	●	●	●																										
	SFC-010DA2	d1	●	●	●	●	●	●																								
		d2	●	●	●	●	●	●																								
	SFC-020DA2	d1	●	●	●	●	●	●	●	●																						
		d2	●	●	●	●	●	●	●	●	●																					
	SFC-025DA2	d1				2.1	●	●	●	●	●	●	●	●	●	●	●	●	●	●	●	●	●	●	●	●	●	●	●	●	●	●
		d2				2.1	●	●	●	●	●	●	●	●	●	●	●	●	●	●	●	●	●	●	●	●	●	●	●	●	●	●
	SFC-030DA2	d1				2.8	3.4	●	●	●	●	●	●	●	●	●	●	●	●	●	●	●	●	●	●	●	●	●	●	●	●	●
		d2				2.8	3.4	●	●	●	●	●	●	●	●	●	●	●	●	●	●	●	●	●	●	●	●	●	●	●	●	●
	SFC-035DA2	d1				5	5	6.6	●	●	●	●	●	●	●	●	●	●	●	●	●	●	●	●	●	●	●	●	●	●	●	●
		d2				5	5	6.6	●	●	●	●	●	●	●	●	●	●	●	●	●	●	●	●	●	●	●	●	●	●	●	●
	SFC-040DA2	d1						9	●	●	●	●	●	●	●	●	●	●	●	●	●	●	●	●	●	●	●	●	●	●	●	●
		d2						9	●	●	●	●	●	●	●	●	●	●	●	●	●	●	●	●	●	●	●	●	●	●	●	●
SFC-050DA2	d1							18	20	22	22	●	●	●	●	●	●	●	●	●	●	●	●	●	●	●	●	●	●	●	●	
	d2							18	20	22	22	●	●	●	●	●	●	●	●	●	●	●	●	●	●	●	●	●	●	●	●	
SFC-055DA2	d1										31	34	36	38	●	●	●	●	●	●	●	●	●	●	●	●	●	●	●	●		
	d2										31	34	36	38	●	●	●	●	●	●	●	●	●	●	●	●	●	●	●	●		
SFC-060DA2	d1											50	51	●	●	●	●	●	●	●	●	●	●	●	●	●	●	●	●	●		
	d2											50	51	●	●	●	●	●	●	●	●	●	●	●	●	●	●	●	●	●		
SFC-080DA2	d1																															
	d2																															
SFC-090DA2	d1																															
	d2																															
SFC-100DA2	d1																															
	d2																															

\* The shaft tolerance for standard bore diameter is h7 (h6 or g6): designation B. However, for a shaft diameter of ø35, the tolerance is  $\pm \frac{0.010}{0.025}$ .  
 \* Shaft tolerances j6/k6: designations J/K are optional, and are only supported for bore diameters marked with ○.  
 \* Bore diameters marked with ● or numbers are supported as the standard bore diameters. Consult Miki Pulley regarding special arrangements which may be possible for other bore diameters.  
 \* Bore diameters whose fields contain numbers are restricted in their rated torque by the holding power of the shaft connection component because the bore diameter is small. The numbers indicate the rated torque [N-m].

How to Place an Order

SFC-025DA2-10B-14K

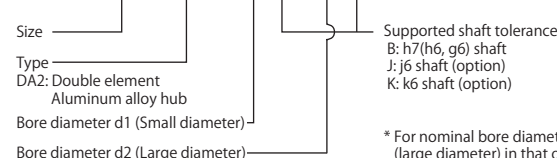

\* For nominal bore diameter, select d1 (small diameter)-d2 (large diameter) in that order.  
 \* If d1=d2 (same diameters), select B, J, and K in that order.

# SFC SA2 Types Single Element Type

## Option Tapered shaft supported

Allows coupling via a clamping hub when a taper adapter is mounted on the tapered shaft of a servo motor.

### Specifications

Model	Type	Rated torque [N·m]	Misalignment			Max. rotation speed [min <sup>-1</sup> ]	Torsional stiffness [N·m/rad]	Axial stiffness [N/mm]	Moment of inertia [kg·m <sup>2</sup> ]	Mass [kg]
			Parallel [mm]	Angular [°]	Axial [mm]					
SFC-040SA2-□ B-11BC	B	12	0.02	1	±0.3	10000	20000	80	26.58 × 10 <sup>-6</sup>	0.131
	C	12	0.02	1	±0.3	10000	20000	80	33.28 × 10 <sup>-6</sup>	0.146
SFC-050SA2-□ B-11BC	B	25	0.02	1	±0.4	10000	32000	48	82.91 × 10 <sup>-6</sup>	0.240
	C	25	0.02	1	±0.4	10000	32000	48	103.5 × 10 <sup>-6</sup>	0.258
SFC-050SA2-□ B-14BC	B	25	0.02	1	±0.4	10000	32000	48	88.72 × 10 <sup>-6</sup>	0.271
	C	25	0.02	1	±0.4	10000	32000	48	111.5 × 10 <sup>-6</sup>	0.301
SFC-050SA2-□ B-16BC	B	25	0.02	1	±0.4	10000	32000	48	95.44 × 10 <sup>-6</sup>	0.309
	C	25	0.02	1	±0.4	10000	32000	48	118.2 × 10 <sup>-6</sup>	0.338
SFC-055SA2-□ B-14BC	C	40	0.02	1	±0.42	10000	50000	43	201.1 × 10 <sup>-6</sup>	0.409
SFC-055SA2-□ B-16BC	C	40	0.02	1	±0.42	10000	50000	43	207.8 × 10 <sup>-6</sup>	0.446
SFC-060SA2-□ B-16BC	B	60	0.02	1	±0.45	10000	70000	76.4	228.7 × 10 <sup>-6</sup>	0.475
	C	60	0.02	1	±0.45	10000	70000	76.4	287.8 × 10 <sup>-6</sup>	0.517

- \* Check the "Standard Bore Diameters" as rated torque may be restricted by the holding power of the shaft connection component.
- \* Max. rotation speed does not take into account dynamic balance.
- \* Torsional stiffness values given are measured values for the element alone.
- \* The moment of inertia and mass are measured for the maximum bore diameter.

### Dimensions

#### TYPE B

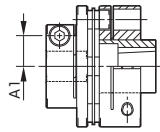

#### TYPE C

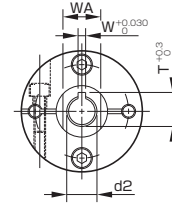
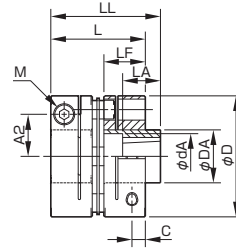

Model	d2 [mm]	W [mm]	T [mm]	WA [mm]	LA [mm]	dA [mm]	DA [mm]	LL [mm]	D [mm]	L [mm]	LF [mm]	C [mm]	A1 [mm]	A2 [mm]	M Qty - Nominal dia.
SFC-040SA2-□ B-11BC	11	4	12.2	18	16	17	22	44	44	34	15.5	4.5	11	17	1-M4
SFC-050SA2-□ B-11BC	11	4	12.2	18	16	17	22	48.4	56	43.4	20.5	6	14.5	22	1-M5
SFC-050SA2-□ B-14BC	14	4	15.1	24	19	22	28	53.4	56	43.4	20.5	6	14.5	22	1-M5
SFC-050SA2-□ B-16BC	16	5	17.3	24	29	26	30	63.4	56	43.4	20.5	6	14.5	22	1-M5
SFC-055SA2-□ B-14BC	14	4	15.1	24	19	22	28	56.6	63	50.6	24	7.75	—	23	1-M6
SFC-055SA2-□ B-16BC	16	5	17.3	24	29	26	30	66.6	63	50.6	24	7.75	—	23	1-M6
SFC-060SA2-□ B-16BC	16	5	17.3	24	29	26	30	69.6	68	53.6	25.2	7.75	17.5	26.5	1-M6

\* For other dimensions, see dimensions for single element type SFC SA2.

### Standard Bore Diameter

		Standard (option) bore diameter, d1 [mm] and restricted rated torque [N·m]																		
Nominal bore diameter		8	9	9.525	10	11	12	13	14	15	16	17	18	19	20	22	24	25	28	30
Shaft tolerance	h7 (h6 · g6)	B	●	●	●	●	●	●	●	●	●	●	●	●	●	●	●	●	●	●
	j6 (Option)	J												○		○	○		○	
	k6 (Option)	K	○							○		○		○		○	○			
Supported diameter	SFC-040SA2	9	●	●	●	●	●	●	●	●	●	●	●	●	●	●	●	●	●	●
	SFC-050SA2	18	20	22	22	●	●	●	●	●	●	●	●	●	●	●	●	●	●	●
	SFC-055SA2				31	34	36	38	●	●	●	●	●	●	●	●	●	●	●	●
	SFC-060SA2					50	51	●	●	●	●	●	●	●	●	●	●	●	●	●

- \* The shaft tolerance for standard bore diameter is h7 (h6 or g6); designation B.
- \* Shaft tolerances j6/k6: designations J/K are optional, and are only supported for bore diameters marked with ○.
- \* Bore diameters marked with ● or numbers are supported as the standard bore diameters. Consult Miki Pulley regarding special arrangements which may be possible for other bore diameters.
- \* Bore diameters whose fields contain numbers are restricted in their rated torque by the holding power of the shaft connection component because the bore diameter is small. The numbers indicate the rated torque [N·m].

### How to Place an Order

#### SFC-050SA2-12B-14BC

Size ———— Bore diameter d1 ———— [d2] BC  
 Type ———— SA2: Single element ———— Supported shaft tolerance  
 Aluminum alloy hub ———— B: h7 (h6, g6), (Option K: k6, J: j6)

# SFC DA2 Types Double Element Type

## Option Tapered shaft supported

Allows coupling via a clamping hub when a taper adapter is mounted on the tapered shaft of a servo motor.

COUPLINGS

ETP BUSHINGS

ELECTROMAGNETIC CLUTCHES & BRAKES

SPEED CHANGERS & REDUCERS

INVERTERS

LINEAR SHAFT DRIVES

TORQUE LIMITERS

ROSTA

SERIES

- Metal Disc Couplings**  
SERVOFLEX
- High-rigidity Couplings  
SERVORIGID
- Metal Slit Couplings  
HELI-CAL
- Metal Coil Spring Couplings  
BAUMANNFLEX
- Pin Bushing Couplings  
PARAFLEX
- Link Couplings  
SCHMIDT
- Rubber and Plastic Couplings**
- Dual Rubber Couplings  
STEPFLEX
- Jaw Couplings  
MIKI PULLEY STARFLEX
- Jaw Couplings  
SPRFLEX
- Plastic Bellows Couplings  
BELLOWFLEX
- Rubber and Plastic Couplings  
CENTAFLEX

MODELS

SFC

SFS

SFF

SFM

SFH

### Specifications

Model	Type	Rated torque [N·m]	Misalignment			Max. rotation speed [min <sup>-1</sup> ]	Torsional stiffness [N·m/rad]	Axial stiffness [N/mm]	Moment of inertia [kg·m <sup>2</sup> ]	Mass [kg]
			Parallel [mm]	Angular [°]	Axial [mm]					
SFC-040DA2-□B-11BC	B	12	0.24	1(On one side)	±0.6	10000	10000	40	39.42 × 10 <sup>-6</sup>	0.180
	C	12	0.24	1(On one side)	±0.6	10000	10000	40	46.12 × 10 <sup>-6</sup>	0.195
SFC-050DA2-□B-11BC	B	25	0.28	1(On one side)	±0.8	10000	16000	24	125.5 × 10 <sup>-6</sup>	0.331
	C	25	0.28	1(On one side)	±0.8	10000	16000	24	146.1 × 10 <sup>-6</sup>	0.349
SFC-050DA2-□B-14BC	B	25	0.28	1(On one side)	±0.8	10000	16000	24	131.1 × 10 <sup>-6</sup>	0.362
	C	25	0.28	1(On one side)	±0.8	10000	16000	24	154.1 × 10 <sup>-6</sup>	0.392
SFC-050DA2-□B-16BC	B	25	0.28	1(On one side)	±0.8	10000	16000	24	138.1 × 10 <sup>-6</sup>	0.400
	C	25	0.28	1(On one side)	±0.8	10000	16000	24	160.8 × 10 <sup>-6</sup>	0.430
SFC-055DA2-□B-14BC	C	40	0.31	1(On one side)	±0.84	10000	25000	21.5	274.0 × 10 <sup>-6</sup>	0.530
SFC-055DA2-□B-16BC	C	40	0.31	1(On one side)	±0.84	10000	25000	21.5	280.5 × 10 <sup>-6</sup>	0.567
SFC-060DA2-□B-16BC	B	60	0.34	1(On one side)	±0.9	10000	35000	38.2	339.4 × 10 <sup>-6</sup>	0.638
	C	60	0.34	1(On one side)	±0.9	10000	35000	38.2	398.5 × 10 <sup>-6</sup>	0.681

\* Check the "Standard Bore Diameters" as rated torque may be restricted by the holding power of the shaft connection component.

\* Max. rotation speed does not take into account dynamic balance.

\* Torsional stiffness values given are measured values for the element alone.

\* The moment of inertia and mass are measured for the maximum bore diameter.

### Dimensions

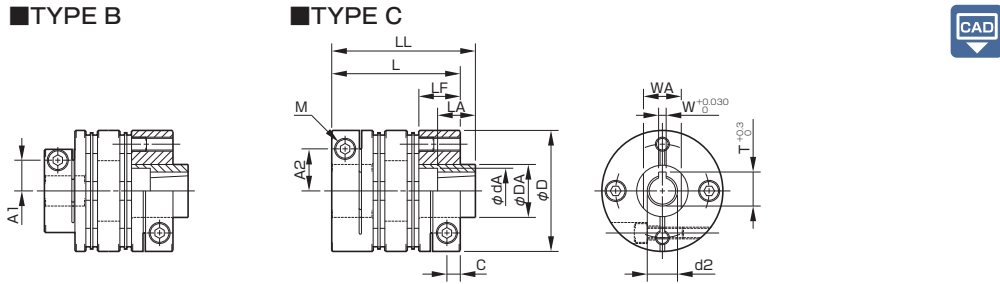

Model	d2 [mm]	W [mm]	T [mm]	WA [mm]	LA [mm]	dA [mm]	DA [mm]	LL [mm]	D [mm]	L [mm]	LF [mm]	C [mm]	A1 [mm]	A2 [mm]	M Qty - Nominal dia.
SFC-040DA2-□B-11BC	11	4	12.2	18	16	17	22	58	44	48	15.5	4.5	11	17	1-M4
SFC-050DA2-□B-11BC	11	4	12.2	18	16	17	22	64.8	56	59.8	20.5	6	14.5	22	1-M5
SFC-050DA2-□B-14BC	14	4	15.1	24	19	22	28	69.8	56	59.8	20.5	6	14.5	22	1-M5
SFC-050DA2-□B-16BC	16	5	17.3	24	29	26	30	79.8	56	59.8	20.5	6	14.5	22	1-M5
SFC-055DA2-□B-14BC	14	4	15.1	24	19	22	28	74.4	63	68.7	24	7.75	—	23	1-M6
SFC-055DA2-□B-16BC	16	5	17.3	24	29	26	30	84.7	63	68.7	24	7.75	—	23	1-M6
SFC-060DA2-□B-16BC	16	5	17.3	24	29	26	30	89.3	68	73.3	25.2	7.75	17.5	26.5	1-M6

\* For other "Specifications" and "Dimensions", see "Specifications" and "Dimensions" for double element type SFC DA2.

### Standard Bore Diameter

		Standard (option) bore diameter, d1 [mm] and restricted rated torque [N·m]																		
Nominal bore diameter		8	9	9.525	10	11	12	13	14	15	16	17	18	19	20	22	24	25	28	30
Shaft tolerance	h7 (h6 · g6)	B	●	●	●	●	●	●	●	●	●	●	●	●	●	●	●	●	●	●
	j6 (Option)	J												○			○			○
	k6 (Option)	K	○	○											○			○		
Supported bore diameter	SFC-040DA2	9	●	●	●	●	●	●	●	●	●	●	●	●	●	●	●	●	●	●
	SFC-050DA2	18	20	22	22	●	●	●	●	●	●	●	●	●	●	●	●	●	●	●
	SFC-055DA2				31	34	36	38	●	●	●	●	●	●	●	●	●	●	●	●
	SFC-060DA2					50	51	●	●	●	●	●	●	●	●	●	●	●	●	●

\* The shaft tolerance for standard bore diameter is h7 (h6 or g6): designation B.

\* Shaft tolerances j6/k6: designations J/K are optional, and are only supported for bore diameters marked with ○.

\* Bore diameters marked with ● or numbers are supported as the standard bore diameters. Consult Miki Pulley regarding special arrangements which may be possible for other bore diameters.

\* Bore diameters whose fields contain numbers are restricted in their rated torque by the holding power of the shaft connection component because the bore diameter is small. The numbers indicate the rated torque [N·m].

### How to Place an Order

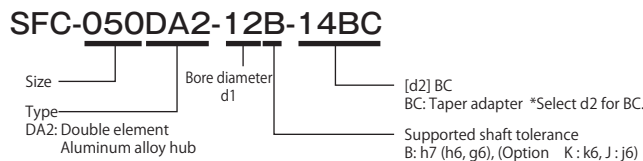

# SFC Models

## Option For length-specified special order parts

SFC DA2 type spacer length can be changed to attain the necessary distance between shafts. Specify the length in 1 mm units.

### Specifications

Model	Type	Rated torque [N·m]	Misalignment				Max. rotation speed [min <sup>-1</sup> ]	Moment of inertia [kg·m <sup>2</sup> ]		Mass [kg]	
			Parallel[mm]		Angular [°]	Axial [mm]		Min. L	Max. L	Min. L	Max. L
			Min. L	Max. L							
SFC-005DA2	C	0.6	0.03	0.20	0.5(On one side)	± 0.1	10000	0.33 × 10 <sup>-6</sup>	0.62 × 10 <sup>-6</sup>	0.009	0.017
SFC-010DA2	C	1	0.08	0.44	1(On one side)	± 0.2	10000	0.72 × 10 <sup>-6</sup>	1.38 × 10 <sup>-6</sup>	0.014	0.026
SFC-020DA2	C	2	0.10	0.46	1(On one side)	± 0.33	10000	3.02 × 10 <sup>-6</sup>	5.30 × 10 <sup>-6</sup>	0.031	0.054
SFC-025DA2	C	4	0.09	0.46	1(On one side)	± 0.38	10000	4.55 × 10 <sup>-6</sup>	7.95 × 10 <sup>-6</sup>	0.036	0.061
SFC-030DA2	A	5	0.11	0.48	1(On one side)	± 0.4	10000	6.09 × 10 <sup>-6</sup>	12.80 × 10 <sup>-6</sup>	0.046	0.085
	B	5	0.11	0.48	1(On one side)	± 0.4	10000	8.11 × 10 <sup>-6</sup>	14.82 × 10 <sup>-6</sup>	0.053	0.091
	C	5	0.11	0.48	1(On one side)	± 0.4	10000	10.22 × 10 <sup>-6</sup>	16.93 × 10 <sup>-6</sup>	0.061	0.099
SFC-035DA2	C	10	0.15	0.54	1(On one side)	± 0.5	10000	23.85 × 10 <sup>-6</sup>	35.97 × 10 <sup>-6</sup>	0.108	0.161
	A	12	0.15	0.54	1(On one side)	± 0.6	10000	25.06 × 10 <sup>-6</sup>	44.76 × 10 <sup>-6</sup>	0.107	0.174
	B	12	0.15	0.54	1(On one side)	± 0.6	10000	30.89 × 10 <sup>-6</sup>	50.62 × 10 <sup>-6</sup>	0.116	0.182
SFC-040DA2	C	12	0.15	0.54	1(On one side)	± 0.6	10000	37.58 × 10 <sup>-6</sup>	57.31 × 10 <sup>-6</sup>	0.130	0.197
	A	25	0.16	0.63	1(On one side)	± 0.8	10000	77.42 × 10 <sup>-6</sup>	144.3 × 10 <sup>-6</sup>	0.205	0.347
	B	25	0.16	0.63	1(On one side)	± 0.8	10000	97.97 × 10 <sup>-6</sup>	164.8 × 10 <sup>-6</sup>	0.225	0.365
SFC-050DA2	C	25	0.16	0.63	1(On one side)	± 0.8	10000	120.8 × 10 <sup>-6</sup>	187.6 × 10 <sup>-6</sup>	0.252	0.394
	A	40	0.16	0.60	1(On one side)	± 0.84	10000	226.8 × 10 <sup>-6</sup>	325.0 × 10 <sup>-6</sup>	0.378	0.538
	B	60	0.19	0.63	1(On one side)	± 0.9	10000	210.8 × 10 <sup>-6</sup>	340.1 × 10 <sup>-6</sup>	0.382	0.567
SFC-060DA2	B	60	0.19	0.63	1(On one side)	± 0.9	10000	269.9 × 10 <sup>-6</sup>	399.2 × 10 <sup>-6</sup>	0.424	0.609
	C	60	0.19	0.63	1(On one side)	± 0.9	10000	333.5 × 10 <sup>-6</sup>	462.8 × 10 <sup>-6</sup>	0.484	0.669

\* Check the "Standard Bore Diameters" for SFC DA2 as there may be limitations on the rated torque caused by the holding power of the coupling shaft section.  
 \* Max. rotation speed does not take into account dynamic balance.  
 \* The moment of inertia and mass are measured for the maximum bore diameter.  
 \* See "Specifications" for SFC DA2 for stiffness values.

### Dimensions

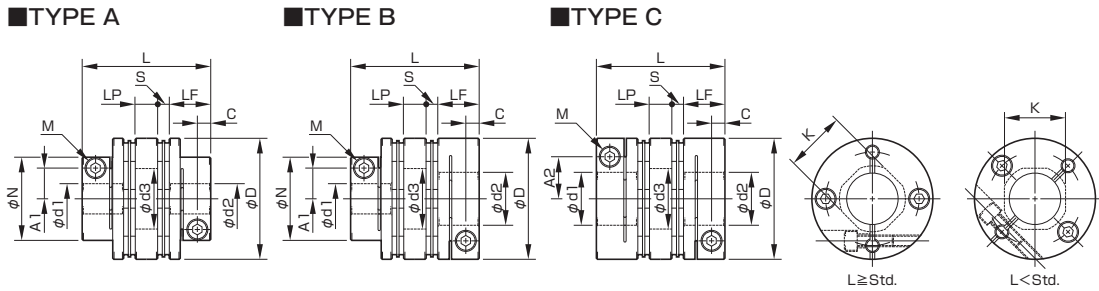

Model	Type	d1 [mm]		d2 [mm]		D [mm]	N [mm]	L [mm]			LF [mm]	S [mm]	A1 [mm]	A2 [mm]	C [mm]	d3 [mm]	K [mm]	M Qty - Nominal dia.	Tightening torque [N·m]
		Min.	Max.	Min.	Max.			Std.	Min.	Max.									
SFC-005DA2	C	3	6	3	6	16	—	23.2	21	40	7.85	1	—	4.8	2.5	6.5	6.5	1-M2	0.4 ~ 0.5
SFC-010DA2	C	3	8	3	8	19	—	25.9	24	45	9.15	1.05	—	5.8(6)	3.15	8.5	8.5	1-M2.5(M2)	1.0~1.1(0.4~0.5)
SFC-020DA2	C	4	10	4	11	26	—	32.3	29	50	10.75	1.65	—	9.5	3.3	10.6	10.6	1-M2.5	1.0 ~ 1.1
SFC-025DA2	C	5	14	5	14	29	—	32.8	29	50	10.75	1.9	—	11	3.3	15	14.5	1-M2.5	1.0 ~ 1.1
SFC-030DA2	A	5	10	5	10	34	21.6	37.8	34	55	12.4	2.5	8	—	3.75	15	14.5	1-M3	1.5 ~ 1.9
	B	5	10	Over 10	16	34	21.6	37.8	34	55	12.4	2.5	8	12.5	3.75	15	14.5	1-M3	1.5 ~ 1.9
	C	Over 10	14	Over 10	16	34	—	37.8	34	55	12.4	2.5	—	12.5	3.75	15	14.5	1-M3	1.5 ~ 1.9
SFC-035DA2	C	6	16	6	19	39	—	48	43	65	15.5	3	—	14	4.5	17	17	1-M4	3.4 ~ 4.1
SFC-040DA2	A	8	15	8	15	44	29.6	48	43	65	15.5	3	11	—	4.5	20	19.5	1-M4	3.4 ~ 4.1
	B	8	15	Over 15	24	44	29.6	48	43	65	15.5	3	11	17	4.5	20	19.5	1-M4	3.4 ~ 4.1
	C	Over 15	19	Over 15	24	44	—	48	43	65	15.5	3	—	17	4.5	20	19.5	1-M4	3.4 ~ 4.1
SFC-050DA2	A	8	19	8	19	56	38	59.8	53	80	20.5	2.4	14.5	—	6	26	26	1-M5	7.0 ~ 8.5
	B	8	19	Over 19	30	56	38	59.8	53	80	20.5	2.4	14.5	22	6	26	26	1-M5	7.0 ~ 8.5
	C	Over 19	25	Over 19	30	56	—	59.8	53	80	20.5	2.4	—	22	6	26	26	1-M5	7.0 ~ 8.5
SFC-055DA2	C	10	30	10	30	63	—	68.7	60	85	24	2.6	—	23	7.75	31	31	1-M6	14 ~ 15
SFC-060DA2	A	11	24	11	24	68	46	73.3	65	90	25.2	3.2	17.5	—	7.75	31	31	1-M6	14 ~ 15
	B	11	24	Over 24	35	68	46	73.3	65	90	25.2	3.2	17.5	26.5	7.75	31	31	1-M6	14 ~ 15
	C	Over 24	30	Over 24	35	68	—	73.3	65	90	25.2	3.2	—	26.5	7.75	31	31	1-M6	14 ~ 15

\* The nominal diameter for the clamping bolt M is equal to the quantity minus the nominal diameter of the screw threads, where the quantity is for a hub on one side.  
 \* The figures in parentheses ( ) for the SFC-010 are the values when d1 or d2 is ø8 mm.  
 \* Compatible lengths L range from the minimum L dimension to the maximum L dimension shown in the above table. Specify in 1 mm units.  
 \* When the L dimension is shorter than the standard, the left/right clamping bolt phases will be off by 45°.  
 \* Check "Standard Bore Diameters" for SFC DA2 for the standard bore diameters.

### How to Place an Order

#### SFC-040DA2-14B-15B-L60

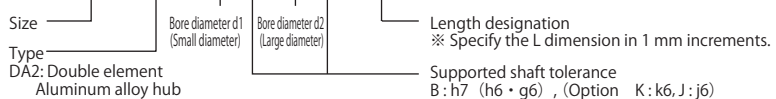

# Option For keyway milling applications

If you are using a keyed shaft, we can mill a keyway in the clamping hub to your specifications.

## Keyway milling standard

### SFC SA2

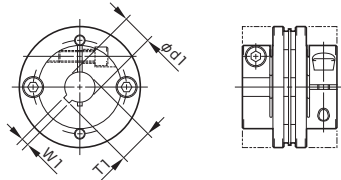

### SFC DA2

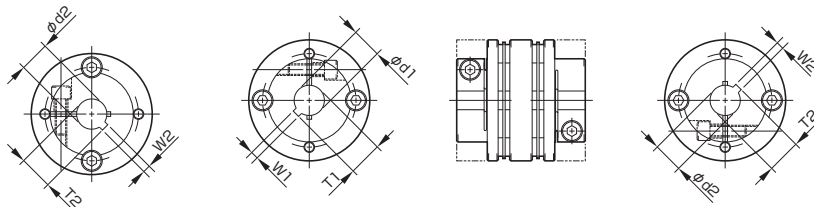

H9 keyway width standards										Js9 keyway width standards																	
Nominal bore dia. Shaft diameter	Shaft tolerance			Bore dia. d1 · d2 [mm]	Keyway width W1 · W2 [mm]	Keyway height T1 · T2 [mm]	Nominal bore dia. Shaft diameter	Shaft tolerance			Bore dia. d1 · d2 [mm]	Keyway width W1 · W2 [mm]	Keyway height T1 · T2 [mm]	Nominal bore dia. Shaft diameter	Shaft tolerance			Bore dia. d1 · d2 [mm]	Keyway width W1 · W2 [mm]	Keyway height T1 · T2 [mm]							
	h7	j6	k6					h7	j6	k6					h7	j6	k6				h7	j6	k6				
8	BH	—	KH	8	3 <sup>+0.025</sup> <sub>0</sub>	9.4 <sup>+0.3</sup> <sub>0</sub>	20	BH	—	—	20	6 <sup>+0.030</sup> <sub>0</sub>	22.8 <sup>+0.3</sup> <sub>0</sub>	8	BJ	—	KJ	8	3 ± 0.0125	9.4 <sup>+0.3</sup> <sub>0</sub>	20	BJ	—	—	20	6 ± 0.0150	22.8 <sup>+0.3</sup> <sub>0</sub>
9	BH	—	KH	9	3 <sup>+0.025</sup> <sub>0</sub>	10.4 <sup>+0.3</sup> <sub>0</sub>	22	BH	JH	KH	22	6 <sup>+0.030</sup> <sub>0</sub>	24.8 <sup>+0.3</sup> <sub>0</sub>	9	BJ	—	KJ	9	3 ± 0.0125	10.4 <sup>+0.3</sup> <sub>0</sub>	22	BJ	JJ	KJ	22	6 ± 0.0150	24.8 <sup>+0.3</sup> <sub>0</sub>
10	BH	—	—	10	3 <sup>+0.025</sup> <sub>0</sub>	11.4 <sup>+0.3</sup> <sub>0</sub>	24	BH	JH	KH	24	8 <sup>+0.036</sup> <sub>0</sub>	27.3 <sup>+0.3</sup> <sub>0</sub>	10	BJ	—	—	10	3 ± 0.0125	11.4 <sup>+0.3</sup> <sub>0</sub>	24	BJ	JJ	KJ	24	8 ± 0.0180	27.3 <sup>+0.3</sup> <sub>0</sub>
11	BH	—	—	11	4 <sup>+0.030</sup> <sub>0</sub>	12.8 <sup>+0.3</sup> <sub>0</sub>	25	BH	—	—	25	8 <sup>+0.036</sup> <sub>0</sub>	28.3 <sup>+0.3</sup> <sub>0</sub>	11	BJ	—	—	11	4 ± 0.0150	12.8 <sup>+0.3</sup> <sub>0</sub>	25	BJ	—	—	25	8 ± 0.0180	28.3 <sup>+0.3</sup> <sub>0</sub>
12	BH	—	—	12	4 <sup>+0.030</sup> <sub>0</sub>	13.8 <sup>+0.3</sup> <sub>0</sub>	28	BH	JH	—	28	8 <sup>+0.036</sup> <sub>0</sub>	31.3 <sup>+0.3</sup> <sub>0</sub>	12	BJ	—	—	12	4 ± 0.0150	13.8 <sup>+0.3</sup> <sub>0</sub>	28	BJ	JJ	—	28	8 ± 0.0180	31.3 <sup>+0.3</sup> <sub>0</sub>
13	BH	—	—	13	5 <sup>+0.030</sup> <sub>0</sub>	15.3 <sup>+0.3</sup> <sub>0</sub>	30	BH	—	—	30	8 <sup>+0.036</sup> <sub>0</sub>	33.3 <sup>+0.3</sup> <sub>0</sub>	13	BJ	—	—	13	5 ± 0.0150	15.3 <sup>+0.3</sup> <sub>0</sub>	30	BJ	—	—	30	8 ± 0.0180	33.3 <sup>+0.3</sup> <sub>0</sub>
14	BH	—	KH	14	5 <sup>+0.030</sup> <sub>0</sub>	16.3 <sup>+0.3</sup> <sub>0</sub>	32	BH	—	KH	32	10 <sup>+0.036</sup> <sub>0</sub>	35.3 <sup>+0.3</sup> <sub>0</sub>	14	BJ	—	KJ	14	5 ± 0.0150	16.3 <sup>+0.3</sup> <sub>0</sub>	32	BJ	—	KJ	32	10 ± 0.0180	35.3 <sup>+0.3</sup> <sub>0</sub>
15	BH	—	—	15	5 <sup>+0.030</sup> <sub>0</sub>	17.3 <sup>+0.3</sup> <sub>0</sub>	35	BH	—	—	35	10 <sup>+0.036</sup> <sub>0</sub>	38.3 <sup>+0.3</sup> <sub>0</sub>	15	BJ	—	—	15	5 ± 0.0150	17.3 <sup>+0.3</sup> <sub>0</sub>	35	BJ	—	—	35	10 ± 0.0180	38.3 <sup>+0.3</sup> <sub>0</sub>
16	BH	—	KH	16	5 <sup>+0.030</sup> <sub>0</sub>	18.3 <sup>+0.3</sup> <sub>0</sub>	38	BH	—	KH	38	10 <sup>+0.036</sup> <sub>0</sub>	41.3 <sup>+0.3</sup> <sub>0</sub>	16	BJ	—	KJ	16	5 ± 0.0150	18.3 <sup>+0.3</sup> <sub>0</sub>	38	BJ	—	KJ	38	10 ± 0.0180	41.3 <sup>+0.3</sup> <sub>0</sub>
17	BH	—	—	17	5 <sup>+0.030</sup> <sub>0</sub>	19.3 <sup>+0.3</sup> <sub>0</sub>	40	BH	—	—	40	12 <sup>+0.043</sup> <sub>0</sub>	43.3 <sup>+0.3</sup> <sub>0</sub>	17	BJ	—	—	17	5 ± 0.0150	19.3 <sup>+0.3</sup> <sub>0</sub>	40	BJ	—	—	40	12 ± 0.0215	43.3 <sup>+0.3</sup> <sub>0</sub>
18	BH	—	—	18	6 <sup>+0.030</sup> <sub>0</sub>	20.8 <sup>+0.3</sup> <sub>0</sub>	42	BH	—	—	42	12 <sup>+0.043</sup> <sub>0</sub>	45.3 <sup>+0.3</sup> <sub>0</sub>	18	BJ	—	—	18	6 ± 0.0150	20.8 <sup>+0.3</sup> <sub>0</sub>	42	BJ	—	—	42	12 ± 0.0215	45.3 <sup>+0.3</sup> <sub>0</sub>
19	BH	JH	KH	19	6 <sup>+0.030</sup> <sub>0</sub>	21.8 <sup>+0.3</sup> <sub>0</sub>	45	BH	—	—	45	14 <sup>+0.043</sup> <sub>0</sub>	48.8 <sup>+0.3</sup> <sub>0</sub>	19	BJ	JJ	KJ	19	6 ± 0.0150	21.8 <sup>+0.3</sup> <sub>0</sub>	45	BJ	—	—	45	14 ± 0.0215	48.8 <sup>+0.3</sup> <sub>0</sub>

\* We can also handle standards not listed above. Consult Miki Pulley.

## Standard Bore Diameter

		Standard (option) bore diameter, d1/d2 [mm] and restricted rated torque [N·m]																									
Nominal bore diameter Shaft diameter			8	9	10	11	12	13	14	15	16	17	18	19	20	22	24	25	28	30	32	35	38	40	42	45	
	h7 (h6 · g6)	B	●	●	●	●	●	●	●	●	●	●	●	●	●	●	●	●	●	●	●	●	●	●	●	●	
j6 (Option)	J																										
	K	○	○																								
k6 (Option)	K																										
SFC-025SA2/DA2	d1	●	●	●	●	●	●	●	●																		
	d2	●	●	●	●	●	●	●	●																		
SFC-030SA2/DA2	d1	●	●	●	●	●	●	●	●	●	●																
	d2	●	●	●	●	●	●	●	●	●	●	●															
SFC-035SA2/DA2	d1	●	●	●	●	●	●	●	●	●	●	●	●														
	d2	●	●	●	●	●	●	●	●	●	●	●	●	●													
SFC-040SA2/DA2	d1	9	●	●	●	●	●	●	●	●	●	●	●	●													
	d2	9	●	●	●	●	●	●	●	●	●	●	●	●	●												
SFC-050SA2/DA2	d1	18	20	22	●	●	●	●	●	●	●	●	●	●	●												
	d2	18	20	22	●	●	●	●	●	●	●	●	●	●	●	●											
SFC-055SA2/DA2	d1			31	34	36	38	●	●	●	●	●	●	●	●	●											
	d2			31	34	36	38	●	●	●	●	●	●	●	●	●	●										
SFC-060SA2/DA2	d1				50	51	●	●	●	●	●	●	●	●	●	●	●										
	d2				50	51	●	●	●	●	●	●	●	●	●	●	●	●									
SFC-080SA2/DA2	d1																										
	d2																										
SFC-090SA2/DA2	d1																										
	d2																										
SFC-100SA2/DA2	d1																										
	d2																										

\* The shaft tolerance for standard bore diameter is h7 (h6 or g6): designation B. However, for a shaft diameter of ø35, the tolerance is ±0.010 / 0.025.

\* Shaft tolerances j6/k6: designations J/K are optional, and are only supported for bore diameters marked with ○.

\* Bore diameters marked with ● or numbers are supported as the standard bore diameters. Consult Miki Pulley regarding special arrangements which may be possible for other bore diameters.

\* Bore diameters whose fields contain numbers are restricted in their rated torque by the holding power of the shaft connection component because the bore diameter is small. The numbers indicate the rated torque [N·m].

## How to Place an Order

### SFC-060SA2-12BH-14KJ

Size: Bore diameter d1 (Small diameter) Bore diameter d2 (Large diameter)  
 Type: SA2: Single element DA2: Double element  
 Affixing method: KJ: k6 shaft + Js9 keyway BH: h7 (h6, g6) shaft + H9 keyway

\* For nominal bore diameter, select d1 (small diameter) -d2 (large diameter) in that order.  
 \* If d1=d2 (same diameters), select B, J, and K in that order.  
 B · J · K · BH · BJ · JH · JJ · KH · KJ

# SFC Models

## Items Checked for Design Purposes

### Spring Characteristics SFC SA2

■ Axial load and amount of displacement

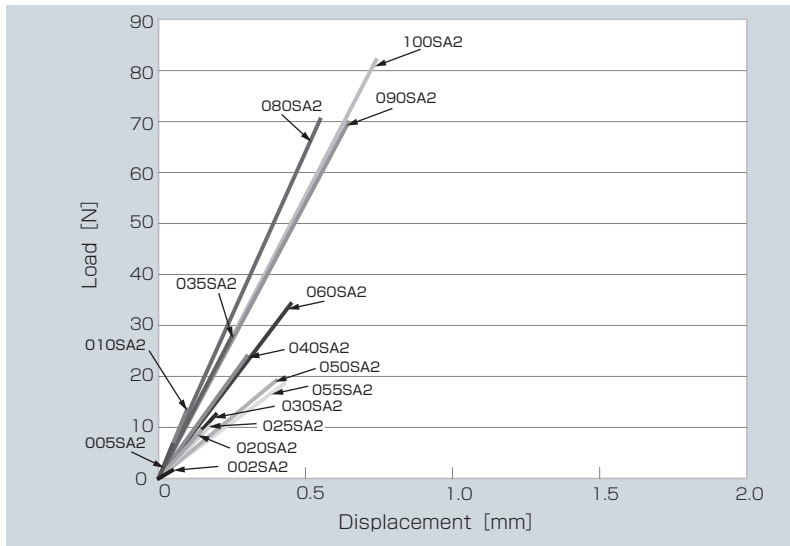
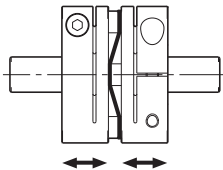

### Spring Characteristics SFC DA2

■ Axial load and amount of displacement

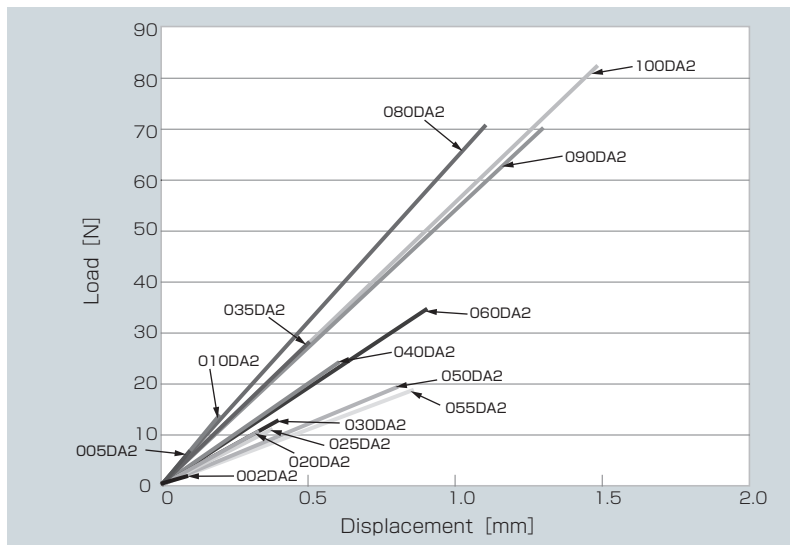
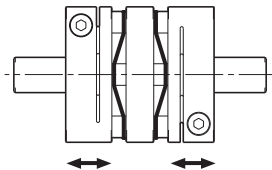

■ Parallel misalignment direction load and amount of displacement

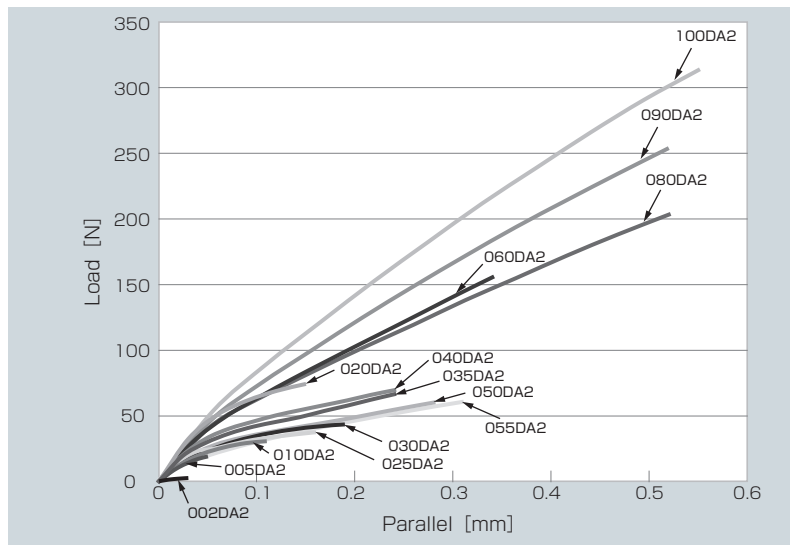
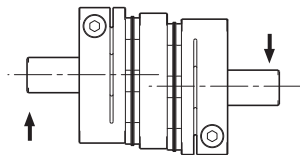

## Special Items to Take Note of

You should note the following to prevent any problems.

- (1) Always be careful of parallel, angular, and axial misalignment.
- (2) Always tighten bolts with the specified torque.

## Precautions for Handling

Couplings are assembled at high accuracy using a special mounting jig to ensure accurate concentricity of left and right internal diameters. Take extra precautions when handling couplings, should strong shocks be given on couplings, it may affect mounting accuracy and cause the parts to break during use.

- (1) Couplings are designed for use within an operating temperature range of -30° C to 100° C. Although the couplings are designed to be waterproof and oilproof, do not subject them to excessive amounts of water and oil as it may cause part deterioration.
- (2) Handle the element with care as it is made of a thin stainless steel metal disc, also making sure to be careful so as not to injure yourself.
- (3) Do not tighten up clamping bolts until after inserting the mounting shaft.

## Mounting

- (1) Check that coupling clamping bolts have been loosened and remove any rust, dust, oil residue, etc. from inner diameter surfaces of the shaft and couplings. In particular, never allow oil or grease containing antifriction or other agent (molybdenum-, silicon-, or fluorine-based), which would dramatically affect the friction coefficient, to contact the surface.
- (2) Be careful when inserting the couplings into the shaft so as not to apply excessive force of compression or tensile force to the element. Be particularly careful not to apply excessive compressing force needlessly when inserting couplings into the paired shaft after attaching the couplings to the motor.
- (3) With two of the clamping bolts loosened, make sure that couplings move gently along the axial and rotational directions. Readjust the centering of the two shafts if the couplings fail to move smoothly enough. This method is recommended as a way to easily check the concentricity of the left and right sides. If unable to use the same method, check the mounting accuracy using machine parts quality control procedures or an alternative method.

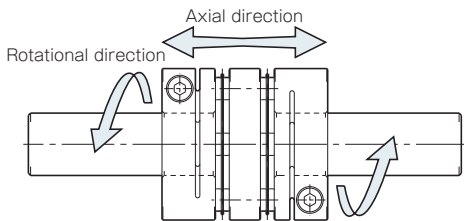

- (4) As a general rule, round shafts are to be used for the paired mounting shaft. If needing to use a shaft with a different shape, be careful not to insert it into any of the locations indicated in the diagrams below. (Do not attempt to face keyways, D-shaped cuts, or other insertions to the grayed areas (□).) Placing the shaft in an undesirable location may cause the couplings to break or lead to a loss in shaft holding power. It is recommended that you use only round shafts to ensure full utilization of the entire range of coupling performance.

## Proper Mounting Examples

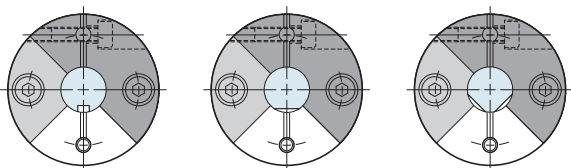

## Poor Mounting Examples

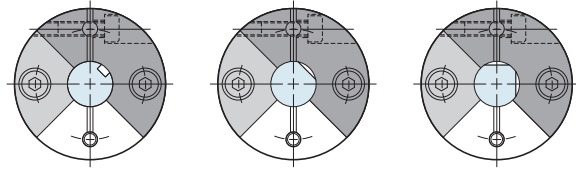

※ □ : Size 002/005, ■ : Size 010 or above

- (5) Insert and mount each shaft far enough in that the paired mounting shaft touches the shaft along the entire length of the clamping hub of the coupling (LF dimension), as shown in the diagram below, and does not interfere with the elements, spacers or the other shaft. In addition, restrict the dimensions between clamping hub faces (S dimensions in the diagram) within the allowable misalignment of the axial direction displacement with respect to a reference value. Note that the tolerance values were calculated based on the assumption that both the level of parallel misalignment and angular deflection are zero. Adjust to keep this value as low as possible.

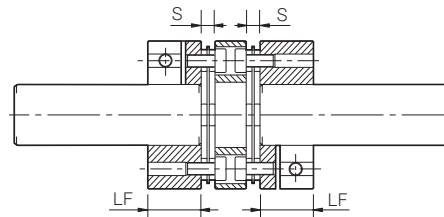

Model	LF [mm]	S [mm]
SFC-002SA2/DA2	5.9	0.55
SFC-005SA2/DA2	7.85	1
SFC-010SA2/DA2	9.15	1.05
SFC-020SA2/DA2	10.75	1.65
SFC-025SA2/DA2	10.75	1.9
SFC-030SA2/DA2	12.4	2.5
SFC-035SA2/DA2	15.5	3
SFC-040SA2/DA2	15.5	3
SFC-050SA2/DA2	20.5	2.4
SFC-055SA2/DA2	24	2.6
SFC-060SA2/DA2	25.2	3.2
SFC-080SA2/DA2	30	8
SFC-090SA2/DA2	30	8.3
SFC-100SA2/DA2	30	9.8

- (6) Check to make sure that no compression or tensile force is being applied along the axial direction before tightening up the two clamping bolts. Use a calibrated torque wrench to tighten the clamping bolts to within the tightening torque range listed below.

Model	Clamping bolts	Tightening torque [N·m]
SFC-002SA2/DA2	M1.6	0.23 ~ 0.28
SFC-005SA2/DA2	M2	0.4 ~ 0.5
SFC-010SA2/DA2	M2	0.4 ~ 0.5
SFC-010SA2/DA2	M2.5	1.0 ~ 1.1
SFC-020SA2/DA2	M2.5	1.0 ~ 1.1
SFC-025SA2/DA2	M2.5	1.0 ~ 1.1
SFC-030SA2/DA2	M3	1.5 ~ 1.9
SFC-035SA2/DA2	M4	3.4 ~ 4.1
SFC-040SA2/DA2	M4	3.4 ~ 4.1
SFC-050SA2/DA2	M5	7.0 ~ 8.5
SFC-055SA2/DA2	M6	14 ~ 15
SFC-060SA2/DA2	M6	14 ~ 15
SFC-080SA2/DA2	M8	27 ~ 30
SFC-090SA2/DA2	M8	27 ~ 30
SFC-100SA2/DA2	M8	27 ~ 30

\* Use M2 bolts on SFC-010SA2/DA2 models with holes with a diameter of ø8 mm.  
 \* The start and end numbers for the tightening torque ranges are between the minimum and maximum values. Tighten bolts to a tightening torque within the specified range for the model used.

### COUPLINGS

ETP BUSHINGS

ELECTROMAGNETIC CLUTCHES & BRAKES

SPEED CHANGERS & REDUCERS

INVERTERS

LINEAR SHAFT DRIVES

TORQUE LIMITERS

ROSTA

### SERIES

Metal Disc Couplings	SERVOFLEX
	High-rigidity Couplings
	SERVORIGID
	Metal Slit Couplings
Metal Couplings	HELI-CAL
	Metal Coil Spring Couplings
	BAUMANNFLEX
Pin Bushing Couplings	PARAFLEX
	Link Couplings
Rubber and Plastic Couplings	SCHMIDT
	Dual Rubber Couplings
	STEPFLEX
	Jaw Couplings
	MIKI PULLEY
	STARFLEX
	Jaw Couplings
	SPRFLEX
	Plastic Bellows Couplings
	BELLOWFLEX
Rubber and Plastic Couplings	
CENTAFLEX	

### MODELS

SFC

SFS

SFF

SFM

SFH



# SFC Models

## Items Checked for Design Purposes

### Suitable Torque Screwdriver/Torque Wrench

Nominal bolt diameter	Tightening torque [N·m]	Torque screwdriver/wrench	Hexagon bit/head	Coupling size
M1.6	0.23 ~ 0.28	CN30LTDK	CB 1.5mm	002
M2	0.4 ~ 0.5	CN60LTDK	SB 1.5mm	005 · 010
M2.5	1.0 ~ 1.1	CN120LTDK	SB 2mm	010 · 020 · 025
M3	1.5 ~ 1.9	CN200LTDK	SB 2.5mm	030
M4	3.4 ~ 4.1	CN500LTDK	SB 3mm	035 · 040
M5	7.0 ~ 8.5	N10LTDK	SB 4mm	050
M6	14 ~ 15	N25LCK	25HCK 5mm	055 · 060
M8	27 ~ 30	N50LCK	50HCK 6mm	080 · 090 · 100

\* Torque screwdriver (wrench)/bit (head) models are those of Nakamura Mfg. Co., Ltd.

### Length-specified Special Order Parts Option

Specify any length for the length-specified special order option for the SERVOFLEX SFC DA2. Use the following formula to calculate the amount of allowable parallel misalignment, adjust it to be no greater than that value, and then mount the coupling.

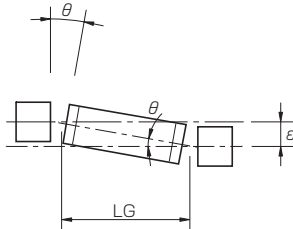

$$\epsilon = \tan \theta \times LG$$

$\epsilon$  : Allowable parallel misalignment [mm]

$\theta$  : Allowable angular deflection [°]

$$LG = LP + S$$

LP : Total length of spacer [mm]

S : Gap size between clamping hub and spacer [mm]

### Options for Keyway Milling

Options for keyway milling are available on request. However, because they are designed such that torque is transferred to the friction coupling by the clamp mechanism, care should be taken not to exceed the coupling's permitted torque during use. Note also the following issues:

- (1) Only ever use keys that are no wider than the keyway. Using keys that are a tight fit could result in damage during mounting or operation.
- (2) The positional accuracy of keyway milling is visual. If positional accuracy relative to keyway hubs is required, contact Miki Pulley.
- (3) Using Js9 class tolerances provides a tight fit, so couplings may be compressed when mounted on shafts. Take care not to further compress the couplings.
- (4) Setting the fit of the key and keyway too loosely may result in play that generates dust. Also take care that the key does not come loose.
- (5) Adding a set screw over the keyway is not recommended as it may lower clamp performance, and the set screw may also become loose within the torque range you use or during forward/reverse operation. It may also impair the structural strength of the clamping hub or damage the coupling.

### Clamping Bolts

Use Miki Pulley-specified clamping bolts because they are processed with solid lubrication films (except for SFC-002 M1.6). Applying adhesives to prevent loosening, oil, or the like to a clamping bolt will alter torque coefficients due to those lubricating components, creating excessive axial forces and potentially damaging the clamping bolt or coupling. Consult Miki Pulley before using such products.

### Surface Processing of Coupling Bore Diameter

The bore diameters of SERVOFLEX SFC models may or may not have surface processing in some components due to the circumstances of processing. This does not affect coupling performance. Consult Miki Pulley if your usage conditions require that bore diameters be surface processed or not.

### Selection Order of Nominal Bore Diameters when Ordering

When specifying bore diameters, you should basically specify d1 (small diameter)-d2 (large diameter), and always specify d2 for taper adapters mounted on tapered shafts. However, where d1=d2 (same diameters), note the selection order below for each nominal bore diameter when ordering.

Nominal bore diameter symbol	Nominal bore diameter symbol description	Type	Selection diameter	Selection order
B	Shaft tolerance h7 (h6, g6)	Standard	d1 · d2	1
J	Shaft tolerance j6	Option	d1 · d2	2
K	Shaft tolerance k6	Option	d1 · d2	3
BH	Shaft tolerance h7 (h6, g6) + keyway H9	Option	d1 · d2	4
BJ	Shaft tolerance h7 (h6, g6) + keyway Js9	Option	d1 · d2	5
JH	Shaft tolerance j6 + keyway H9	Option	d1 · d2	6
JJ	Shaft tolerance j6 + keyway Js9	Option	d1 · d2	7
KH	Shaft tolerance k6 + keyway H9	Option	d1 · d2	8
KJ	Shaft tolerance k6 + keyway Js9	Option	d1 · d2	9
BC	Taper adapter mounted on tapered shaft	Option	d2	10

### Points to Consider Regarding the Feed Screw System

#### Servo motor oscillation

Gain adjustment on the servo motor may cause the servo motor to oscillate.

Oscillation in the servo motor during operation can cause problems particularly with the overall natural frequency and electrical control systems of the feed screw system.

In order for these issues to be resolved, the torsional stiffness for the coupling and feed screw section and the moment of inertia and other characteristics for the system overall will need to be adjusted and the torsional natural frequency for the mechanical system raised or the tuning function (filter function) for the electrical control system in the servo motor adjusted during the design stage.

#### Stepper motor resonance

Stepper motors resonate at certain rotation speeds due to the pulsation frequency of the stepper motor and the torsional natural frequency of the system as a whole. To avoid resonance, either the resonant rotation speed must be simply skipped or the torsional natural frequency considered at the design stage.

Please contact Miki Pulley with any questions regarding stepper motor resonance or servo motor oscillation.

### How to Find the Natural Frequency of a Feed Screw System

- (1) Select a coupling based on the nominal and maximum torque of the servo motor or stepper motor.
- (2) Find the overall natural frequency, Nf, from the torsional stiffness of the coupling and feed screw,  $\kappa$ , the moment of inertia of driving side, J1, and the moment of inertia of driven side, J2, for the feed screw system shown below.

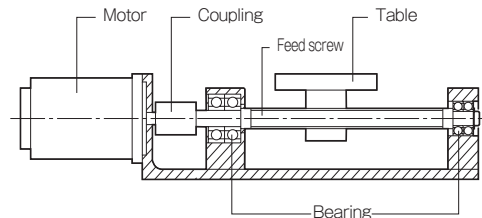

$$Nf = \frac{1}{2\pi} \sqrt{\kappa \left( \frac{1}{J1} + \frac{1}{J2} \right)}$$

Nf: Overall natural frequency of a feed screw system [Hz]

$\kappa$  : Torsional stiffness of the coupling and feed screw [N·m/rad]

J1: Moment of inertia of driving side [kg·m<sup>2</sup>]

J2: Moment of inertia of driven side [kg·m<sup>2</sup>]

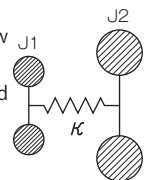

## Selection Procedures

(1) Find the torque,  $T_a$ , applied to the coupling using the output capacity,  $P$ , of the driver and the usage rotation speed,  $n$ .

$$T_a \text{ [N}\cdot\text{m]} = 9550 \times \frac{P \text{ [kW]}}{n \text{ [min}^{-1}\text{]}}$$

(2) Determine the factor  $K$  from the load properties, and find the corrected torque,  $T_d$ , applied to the coupling.

$$T_d \text{ [N}\cdot\text{m]} = T_a \text{ [N}\cdot\text{m]} \times K \text{ (Refer to the table below for values)}$$

Load properties	Constant	Vibrations: Small	Vibrations: Medium	Vibrations: Large
K	1.0	1.25	1.75	2.25

For servo motor drive, multiply the maximum torque,  $T_s$ , by the usage factor  $K = 1.2$  to  $1.5$ .

$$T_d \text{ [N}\cdot\text{m]} = T_s \text{ [N}\cdot\text{m]} \times (1.2 \sim 1.5)$$

(3) Set the size so that the rated coupling torque,  $T_n$ , is higher than the corrected torque,  $T_d$ .

$$T_n \text{ [N}\cdot\text{m]} \geq T_d \text{ [N}\cdot\text{m]}$$

(4) The rated torque of the coupling may be limited by the bore diameter of the coupling. See the Specifications and Standard Bore Diameters tables.

(5) Check that the mount shaft is no larger than the maximum bore diameter of the coupling.

\*Contact Miki Pulley for assistance with any device experiencing extreme periodic vibrations.

## Easy Selection Chart

Select a coupling size based on the rated output and the rated/maximum torque of the ordinary servo motor. The torque characteristics of servo motors vary between manufacturers, so check the specifications in the manufacturer catalog before finalizing a coupling size selection.

Servo motor specifications					Corresponding SERVOFLEX type specifications				
Rated output [W] [kW]	Rated rotation speed [min <sup>-1</sup> ]	Rated torque [N·m]	Max. torque [N·m]	Shaft diameter [mm]	Single element type	Double element type	Rated torque [N·m]	Max. bore diameter [mm]	Outer diameter [mm]
3W	3000 ~ 6000	0.0096	0.029	4	SFC-002SA2	SFC-002DA2	0.25	5	12
5W	3000 ~ 6000	0.016	0.048	5	SFC-002SA2	SFC-002DA2	0.25	5	12
10W	3000 ~ 6000	0.032	0.096	6	SFC-005SA2	SFC-005DA2	0.6	6	16
15W	3000 ~ 6000	0.047	0.143	4	SFC-002SA2	SFC-002DA2	0.25	5	12
20W	3000 ~ 6000	0.0638	0.191	6	SFC-005SA2	SFC-005DA2	0.6	6	16
30W	3000 ~ 6000	0.098	0.322	8	SFC-010SA2	SFC-010DA2	1	8	19
50W	3000 ~ 6000	0.16	0.64	8	SFC-010SA2	SFC-010DA2	1	8	19
100W	3000 ~ 6000	0.32	1.28	8	SFC-020SA2	SFC-020DA2	2	11	26
150W	3000 ~ 6000	0.477	1.67	8	SFC-025SA2	SFC-025DA2	4	14	29
200W	3000 ~ 6000	0.64	2.23	14	SFC-025SA2	SFC-025DA2	4	14	29
300W	3000 ~ 6000	0.95	3.72	14	SFC-030SA2	SFC-030DA2	5	16	34
400W	3000 ~ 6000	1.3	5	14	SFC-035SA2	SFC-035DA2	10	19	39
450W	1500	2.86	8.92	19	SFC-040SA2	SFC-040DA2	12	24	44
500W	2000	2.4	7.2	24	SFC-040SA2	SFC-040DA2	12	24	44
600W	3000 ~ 6000	1.91	5.73	19	SFC-035SA2	SFC-035DA2	10	19	39
750W	3000 ~ 6000	2.387	9	19	SFC-040SA2	SFC-040DA2	12	24	44
750W	2000	3.6	10.7	22	SFC-050SA2	SFC-050DA2	25	30	56
850W	1500	5.39	13.8	19	SFC-050SA2	SFC-050DA2	25	30	56
1kW	3000 ~ 6000	3.18	12.5	24	SFC-050SA2	SFC-050DA2	25	30	56
1kW	2000	5	16.6	24	SFC-050SA2	SFC-050DA2	25	30	56
1.5kW	2000	7.5	21.6	35	SFC-060SA2	SFC-060DA2	60	35	68
2kW	3000 ~ 6000	6.8	21	24	SFC-055SA2	SFC-055DA2	40	30	63
2kW	2000	9.54	31	35	SFC-060SA2	SFC-060DA2	60	35	68
2.2kW	2000	10.5	36.7	28	SFC-060SA2	SFC-060DA2	60	35	68
2.5kW	3000 ~ 6000	12	46	24	SFC-060SA2	SFC-060DA2	60	35	68
3kW	3000 ~ 6000	12	35	28	SFC-060SA2	SFC-060DA2	60	35	68
3kW	2000	14.3	42.9	35	SFC-060SA2	SFC-060DA2	60	35	68
3.5kW	3000 ~ 6000	11.1	33.4	28	SFC-060SA2	SFC-060DA2	60	35	68
3.5kW	2000	17	55	35	SFC-080SA2	SFC-080DA2	100	40	82
4kW	3000 ~ 6000	22	39.2	28	SFC-060SA2	SFC-060DA2	60	35	68
4kW	2000	19.1	66.9	35	SFC-080SA2	SFC-080DA2	100	40	82
4.5kW	1500	28.5	105	35	SFC-090SA2	SFC-090DA2	180	45	94
5kW	3000 ~ 6000	15.9	47.6	28	SFC-080SA2	SFC-080DA2	100	40	82
5kW	2000	23.9	71.6	35	SFC-080SA2	SFC-080DA2	100	40	82
6kW	2000	38	130	35	SFC-090SA2	SFC-090DA2	180	45	94
7kW	1500	44.6	134	42	SFC-090SA2	SFC-090DA2	180	45	94
7.5kW	1500	48	139	42	SFC-100SA2	SFC-100DA2	250	45	104
9kW	3000 ~ 6000	28.6	85	35	SFC-090SA2	SFC-090DA2	180	45	94
11kW	2000	52.5	158	42	SFC-100SA2	SFC-100DA2	250	45	104

### COUPLINGS

ETP BUSHINGS

ELECTROMAGNETIC CLUTCHES & BRAKES

SPEED CHANGERS & REDUCERS

INVERTERS

LINEAR SHAFT DRIVES

TORQUE LIMITERS

ROSTA

### SERIES

Metal Couplings	Metal Disc Couplings SERVOFLEX
	High-rigidity Couplings SERVORIGID
	Metal Slit Couplings HELI-CAL
	Metal Coil Spring Couplings BAUMANNFLEX
Rubber and Plastic Couplings	Pin Bushing Couplings PARAFLEX
	Link Couplings SCHMIDT
	Dual Rubber Couplings STEPFLEX
Rubber and Plastic Couplings	Jaw Couplings MIKI PULLEY STARFLEX
	Jaw Couplings SPRFLEX
	Plastic Bellows Couplings BELLOWFLEX
Rubber and Plastic Couplings	Rubber and Plastic Couplings CENTAFLEX

### MODELS

SFC

SFS

SFF

SFM

SFH

# SFS S Types Single Element Type

## Specifications

Model	Rated torque [N·m]	Misalignment		Max. rotation speed [min <sup>-1</sup> ]	Torsional stiffness [N·m/rad]	Axial stiffness [N/mm]	Moment of inertia [kg·m <sup>2</sup> ]	Mass [kg]
		Angular [°]	Axial [mm]					
SFS-05S	20	1	± 0.6	25000	16000	43	0.11 × 10 <sup>-3</sup>	0.30
SFS-06S	40	1	± 0.8	20000	29000	45	0.30 × 10 <sup>-3</sup>	0.50
SFS-08S	80	1	± 1.0	17000	83000	60	0.87 × 10 <sup>-3</sup>	1.00
SFS-09S	180	1	± 1.2	15000	170000	122	1.60 × 10 <sup>-3</sup>	1.40
SFS-10S	250	1	± 1.4	13000	250000	160	2.60 × 10 <sup>-3</sup>	2.10
SFS-12S	450	1	± 1.6	11000	430000	197	6.50 × 10 <sup>-3</sup>	3.40
SFS-14S	800	1	± 1.8	9500	780000	313	9.90 × 10 <sup>-3</sup>	4.90
SFS-05S-C	15	1	± 0.6	25000	16000	43	0.11 × 10 <sup>-3</sup>	0.30
SFS-06S-C	30	1	± 0.8	20000	29000	45	0.30 × 10 <sup>-3</sup>	0.50
SFS-08S-C	60	1	± 1.0	17000	83000	60	0.87 × 10 <sup>-3</sup>	1.00
SFS-09S-C	135	1	± 1.2	15000	170000	122	1.60 × 10 <sup>-3</sup>	1.40
SFS-10S-C	190	1	± 1.4	13000	250000	160	2.60 × 10 <sup>-3</sup>	2.10
SFS-12S-C	340	1	± 1.6	11000	430000	197	6.50 × 10 <sup>-3</sup>	3.40
SFS-14S-C	600	1	± 1.8	9500	780000	313	9.90 × 10 <sup>-3</sup>	4.90
SFS-06S-□ M-□ M	40	1	± 0.8	5000	29000	45	0.30 × 10 <sup>-3</sup>	0.70
SFS-08S-□ M-□ M	80	1	± 1.0	5000	83000	60	0.93 × 10 <sup>-3</sup>	1.30
SFS-09S-□ M-□ M	180	1	± 1.2	5000	170000	122	1.80 × 10 <sup>-3</sup>	1.80
SFS-10S-□ M-□ M	250	1	± 1.4	5000	250000	160	2.70 × 10 <sup>-3</sup>	2.30
SFS-12S-□ M-□ M	450	1	± 1.6	5000	430000	197	6.80 × 10 <sup>-3</sup>	4.10
SFS-14S-35M-35M	580	1	± 1.8	5000	780000	313	14.01 × 10 <sup>-3</sup>	6.40
SFS-06S-□ M-11C	40	1	± 0.8	5000	29000	45	0.29 × 10 <sup>-3</sup>	0.60
SFS-06S-15M-16C	40	1	± 0.8	5000	29000	45	0.34 × 10 <sup>-3</sup>	0.70
SFS-08S-□ M-16C	80	1	± 1.0	5000	83000	60	0.84 × 10 <sup>-3</sup>	1.20
SFS-09S-□ M-16C	180	1	± 1.2	5000	170000	122	1.50 × 10 <sup>-3</sup>	1.60

\*Max. rotation speed does not take into account dynamic balance.

\*The moment of inertia and mass are measured for the maximum bore diameter.

## Dimension (SFS-□ S) Pilot Bore/Key or Set Screw

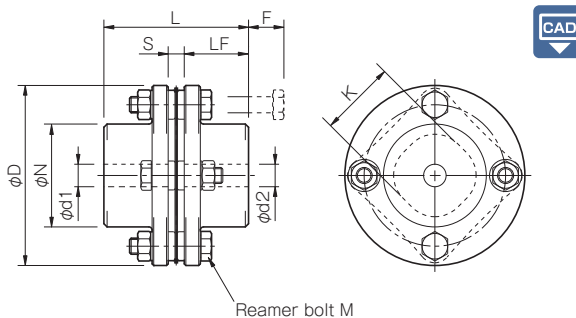

Unit [mm]

Model	d1 · d2			D	N	L	LF	S	F	K	M
	Pilot bore	Min.	Max.								
SFS-05S	7	8	20	56	32	45	20	5	11	24	4-M5 × 22
SFS-06S	7	8	25	68	40	56	25	6	10	30	4-M6 × 25
SFS-08S	10	11	35	82	54	66	30	6	11	38	4-M6 × 29
SFS-09S	10	11	38	94	58	68	30	8	21	42	4-M8 × 36
SFS-10S	15	16	42	104	68	80	35	10	16	48	4-M8 × 36
SFS-12S	18	19	50	126	78	91	40	11	23	54	4-M10 × 45
SFS-14S	20	22	60	144	88	102	45	12	31	61	4-M12 × 54

\* Pilot bores are to be drilled into the part. See the standard hole-drilling standards of P.54 for information on bore drilling.

\* The nominal diameter of the reamer bolt M is equal to the quantity minus the nominal diameter of the screw threads times the nominal length.

### How to Place an Order

### SFS-10S-C-25H-30H

- Size: 10
- Type: S
- Surface finishing options: Blank, -C: Electroless nickel plating
- Bore diameter: d1 (Small diameter) - d2 (Large diameter)
- Blank: Pilot bore
- Bore specifications: Blank: Compliant with the old JIS standards (class 2) E9
- H: Compliant with the new JIS standards H9
- J: Compliant with the new JIS standards Js9
- P: Compliant with the new JIS standards P9
- N: Compliant with the new motor standards

COUPLINGS

ETP BUSHINGS

ELECTROMAGNETIC CLUTCHES & BRAKES

SPEED CHANGERS & REDUCERS

INVERTERS

LINEAR SHAFT DRIVES

TORQUE LIMITERS

ROSTA

SERIES

Metal Disc Couplings	SERVOFLEX
	High-rigidity Couplings
	SERVORIGID
	Metal Slit Couplings
Metal Couplings	HELI-CAL
	Metal Coil Spring Couplings
	BAUMANNFLEX
Pin Bushing Couplings	PARAFLEX
	Link Couplings
Rubber and Plastic Couplings	SCHMIDT
	Dual Rubber Couplings
	STEPFLEX
	Jaw Couplings
	MIKI PULLEY
	STARFLEX
	Jaw Couplings
	SPRFLEX
	Plastic Bellows Couplings
	BELLOWFLEX
Rubber and Plastic Couplings	
CENTAFLEX	

MODELS

SFC

SFS

SFF

SFM

SFH

Dimensions (SFS- □ S- □ M- □ M) Frictional Coupling

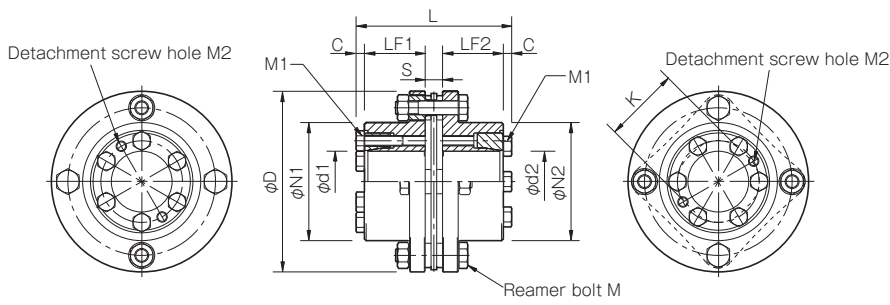

Model	Bore diameter	d1	d2	D	N1	N2	L	LF1	LF2	S	C	K	M	M1	M2
SFS-06S	□ M-□ M	12·14·15	12·14·15	68	40	40	65.6	25	25	6	4.8	30	4-M6 × 25	4-M5	2-M5
SFS-08S	□ M-□ M	15·16·20·22	15·16·20·22	82	54	54	75.6	30	30	6	4.8	38	4-M6 × 29	4-M6	2-M6
SFS-09S	□ M-□ M	25·28	25·28	94	58	58	77.6	30	30	8	4.8	42	4-M8 × 36	6-M6	2-M6
	□ M-35M	25·28	35	68	68	85.6	38	38							
SFS-10S	□ M-□ M	25·28·30·35	25·28·30·35	104	68	68	89.6	35	35	10	4.8	48	4-M8 × 36	6-M6	2-M6
SFS-12S	□ M-□ M*1	30·35	30·35	126	78	78	101.6	40	40	11	5.3	54	4-M10 × 45	4-M8	2-M8
SFS-14S	35M-35M	35	35	144	88	88	112.6	45	45	12	5.3	61	4-M12 × 54	6-M8	2-M8

\* For a standard bore diameter, consult Miki Pulley as restrictions may apply to the permitted torque.  
 \* The nominal diameters of each bolt and tap are equal to the quantity minus the nominal diameter of the screw threads times the nominal length. The quantities for the pressure bolt M1 and detachment screw hole M2 are quantities for the hub on one side.  
 \* The rated torque of SFS-12S-30M-□ M in note \*1 is limited by the ø30 shaft coupling mechanism and is 380 N·m.  
 \* The machining tolerance for paired mounting shafts is h7 (h6 or g6) class. However, for a shaft diameter of 35 mm, the tolerance is  $^{+0.010}_{-0.025}$ .

How to Place an Order

SFS-10S-25M-30M

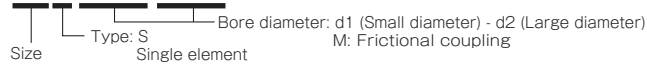

Dimension (SFS- □ S- □ M- □ C) Frictional Coupling/Tapered Shaft Supported

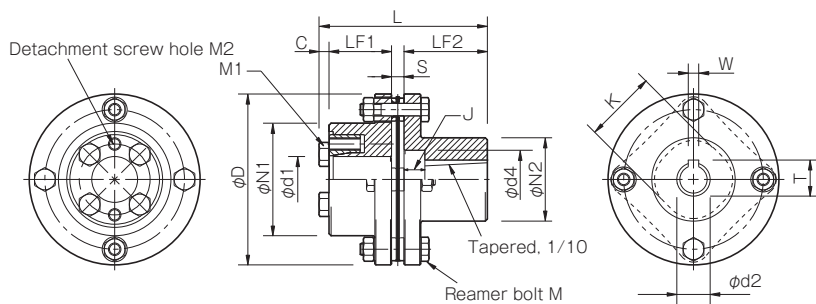

Model	Bore diameter	d1	d2	W $^{+0.030}_0$	T $^{+0.3}_0$	d4	J	D	N1	N2	L	LF1	LF2	S	C	K	M	M1	M2
SFS-06S	□ M-11C	12·14·15	11	4	12.2	18	9	68	40	40	60.8	25	25	6	4.8	30	4-M6 × 25	4-M5	2-M5
	15M-16C	15	16	5	17.3	28	10	82	54	40	80.8	30	40	6	4.8	38	4-M6 × 29	4-M6	2-M6
SFS-08S	□ M-16C	15·16·20·22	16	5	17.3	28	10	94	58	40	82.8	30	40	8	4.8	42	4-M8 × 36	6-M6	2-M6

\* For a standard bore diameter, consult Miki Pulley as restrictions may apply to the permitted torque.  
 \* The nominal diameters of each bolt and tap are equal to the quantity minus the nominal diameter of the screw threads times the nominal length.  
 \* The machining tolerance for paired mounting shafts of the hub on the friction-coupled side is h7 (h6 or g6) class.

How to Place an Order

SFS-08S-20M-16C

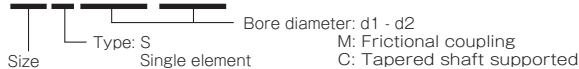

# SFS W Types Double Element Type

## Specifications

Model	Rated torque [N·m]	Misalignment			Max. rotation speed [min <sup>-1</sup> ]	Torsional stiffness [N·m/rad]	Axial stiffness [N/mm]	Moment of inertia [kg·m <sup>2</sup> ]	Mass [kg]
		Parallel [mm]	Angular [°]	Axial [mm]					
SFS-05W	20	0.2	1 (On one side)	± 1.2	10000	8000	21	0.14 × 10 <sup>-3</sup>	0.40
SFS-06W	40	0.3	1 (On one side)	± 1.6	8000	14000	22	0.41 × 10 <sup>-3</sup>	0.70
SFS-08W	80	0.3	1 (On one side)	± 2.0	6800	41000	30	1.10 × 10 <sup>-3</sup>	1.30
SFS-09W	180	0.5	1 (On one side)	± 2.4	6000	85000	61	2.20 × 10 <sup>-3</sup>	2.10
SFS-10W	250	0.5	1 (On one side)	± 2.8	5200	125000	80	3.60 × 10 <sup>-3</sup>	2.80
SFS-12W	450	0.6	1 (On one side)	± 3.2	4400	215000	98	9.20 × 10 <sup>-3</sup>	4.90
SFS-14W	800	0.7	1 (On one side)	± 3.6	3800	390000	156	15.00 × 10 <sup>-3</sup>	7.10
SFS-05W-C	15	0.2	1 (On one side)	± 1.2	10000	8000	21	0.14 × 10 <sup>-3</sup>	0.40
SFS-06W-C	30	0.3	1 (On one side)	± 1.6	8000	14000	22	0.41 × 10 <sup>-3</sup>	0.70
SFS-08W-C	60	0.3	1 (On one side)	± 2.0	6800	41000	30	1.10 × 10 <sup>-3</sup>	1.30
SFS-09W-C	135	0.5	1 (On one side)	± 2.4	6000	85000	61	2.20 × 10 <sup>-3</sup>	2.10
SFS-10W-C	190	0.5	1 (On one side)	± 2.8	5200	125000	80	3.60 × 10 <sup>-3</sup>	2.80
SFS-12W-C	340	0.6	1 (On one side)	± 3.2	4400	215000	98	9.20 × 10 <sup>-3</sup>	4.90
SFS-14W-C	600	0.7	1 (On one side)	± 3.6	3800	390000	156	15.00 × 10 <sup>-3</sup>	7.10
SFS-06W-□ M-□ M	40	0.3	1 (On one side)	± 1.6	5000	14000	22	0.41 × 10 <sup>-3</sup>	0.90
SFS-08W-□ M-□ M	80	0.3	1 (On one side)	± 2.0	5000	41000	30	1.16 × 10 <sup>-3</sup>	1.60
SFS-09W-□ M-□ M	180	0.5	1 (On one side)	± 2.4	5000	85000	61	2.40 × 10 <sup>-3</sup>	2.50
SFS-10W-□ M-□ M	250	0.5	1 (On one side)	± 2.8	5000	125000	80	3.70 × 10 <sup>-3</sup>	3.00
SFS-12W-□ M-□ M	450	0.6	1 (On one side)	± 3.2	4400	215000	98	9.50 × 10 <sup>-3</sup>	5.60
SFS-14W-35M-35M	580	0.7	1 (On one side)	± 3.6	3800	390000	156	19.11 × 10 <sup>-3</sup>	8.60
SFS-06W-□ M-11C	40	0.3	1 (On one side)	± 1.6	5000	14000	22	0.40 × 10 <sup>-3</sup>	0.80
SFS-06W-15M-16C	40	0.3	1 (On one side)	± 1.6	5000	14000	22	0.45 × 10 <sup>-3</sup>	0.90
SFS-08W-□ M-16C	80	0.3	1 (On one side)	± 2.0	5000	41000	30	1.07 × 10 <sup>-3</sup>	1.50
SFS-09W-□ M-16C	180	0.5	1 (On one side)	± 2.4	5000	85000	61	2.10 × 10 <sup>-3</sup>	2.30

\* Max. rotation speed does not take into account dynamic balance.  
 \* The moment of inertia and mass are measured for the maximum bore diameter.

## Dimension (SFS- □ W) Pilot Bore/Key or Set Screw

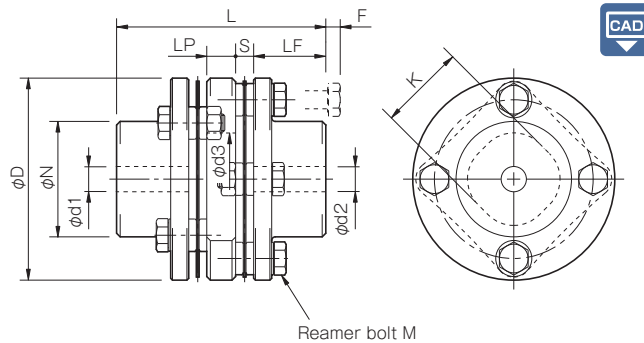

Model	d1 · d2			D	N	L	LF	LP	S	F	d3	K	M
	Pilot bore	Min.	Max.										
SFS-05W	7	8	20	56	32	58	20	8	5	4	20	24	8-M5 × 15
SFS-06W	7	8	25	68	40	74	25	12	6	3	24	30	8-M6 × 18
SFS-08W	10	11	35	82	54	84	30	12	6	2	28	38	8-M6 × 20
SFS-09W	10	11	38	94	58	98	30	22	8	12	32	42	8-M8 × 27
SFS-10W	15	16	42	104	68	110	35	20	10	7	34	48	8-M8 × 27
SFS-12W	18	19	50	126	78	127	40	25	11	10	40	54	8-M10 × 32
SFS-14W	20	22	60	144	88	144	45	30	12	15	46	61	8-M12 × 38

\*Pilot bores are to be drilled into the part. See the standard hole-drilling standards of JIS for information on bore drilling.  
 \*The nominal diameter of the reamer bolt is equal to the quantity minus the nominal diameter of the screw threads times the nominal length.

### How to Place an Order

### SFS-10W-C-25H-30H

Size: 10W  
 Surface finishing options: C (Electroless nickel plating)  
 Type: W (Double element)  
 Bore diameter: d1 (Small diameter) - d2 (Large diameter)  
 Bore specifications: H (Compliant with the new JIS standards H9), J (Compliant with the new JIS standards Js9), P (Compliant with the new JIS standards P9), N (Compliant with the new motor standards)

## COUPLINGS

ETP BUSHINGS

ELECTROMAGNETIC CLUTCHES & BRAKES  
SPEED CHANGERS & REDUCERS

INVERTERS

LINEAR SHAFT DRIVES

TORQUE LIMITERS

ROSTA

## SERIES

Metal Disc Couplings  
**SERVOFLEX**

High-rigidity Couplings  
**SERVORIGID**

Metal Slit Couplings  
**HELI-CAL**

Metal Coil Spring Couplings  
**BAUMANNFLEX**

Pin Bushing Couplings  
**PARAFLEX**

Link Couplings  
**SCHMIDT**

Dual Rubber Couplings  
**STEPFLEX**

Jaw Couplings  
**MIKI PULLEY STARFLEX**

Jaw Couplings  
**SPRFLEX**

Plastic Bellows Couplings  
**BELLOWFLEX**

Rubber and Plastic Couplings  
**CENTAFLEX**

## MODELS

SFC

SFS

SFF

SFM

SFH

## Dimensions (SFS- □ W- □ M- □ M) Frictional Coupling

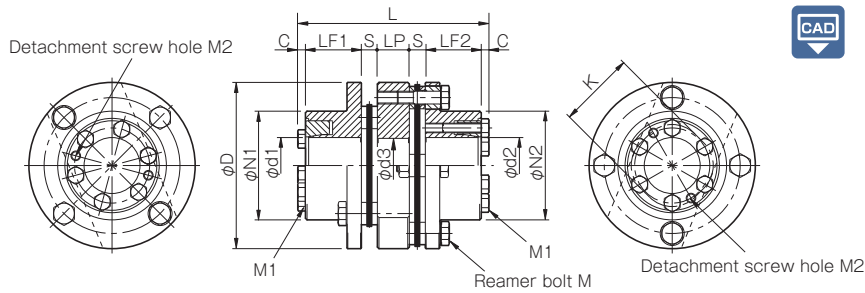

Model	Bore diameter	d1	d2	D	N1	N2	L	LF1	LF2	LP	S	C	d3	K	M	M1	M2
SFS-06W	□ M-□ M	12·14·15	12·14·15	68	40	40	83.6	25	25	12	6	4.8	24	30	8-M6 × 18	4-M5	2-M5
SFS-08W	□ M-□ M	15·16·20·22	15·16·20·22	82	54	54	93.6	30	30	12	6	4.8	28	38	8-M6 × 20	4-M6	2-M6
SFS-09W	□ M-□ M	25·28	25·28	94	58	58	107.6	30	30	22	8	4.8	32	42	8-M8 × 27	6-M6	2-M6
	□ M-35M	25·28	35				115.6										
SFS-10W	□ M-□ M	25·28·30·35	25·28·30·35	104	68	68	119.6	35	35	20	10	4.8	34	48	8-M8 × 27	6-M6	2-M6
SFS-12W	□ M-□ M*1	30·35	30·35	126	78	78	137.6	40	40	25	11	5.3	40	54	8-M10 × 32	4-M8	2-M8
SFS-14W	35M-35M	35	35	144	88	88	154.6	45	45	30	12	5.3	46	61	8-M12 × 38	6-M8	2-M8

\* For a standard bore diameter, consult Miki Pulley as restrictions may apply to the permitted torque.  
 \* The nominal diameters of each bolt and tap are equal to the quantity minus the nominal diameter of the screw threads times the nominal length. The quantities for the pressure bolt M1 and detachment screw hole M2 are quantities for the hub on one side.  
 \* The rated torque of SFS-12W-30M-□ M in note \*1 is limited by the φ35 shaft coupling mechanism and is 380 N·m.  
 \* The machining tolerance for paired mounting shafts is h7 (h6 or g6) class.

### How to Place an Order

### SFS-10W-25M-30M

Size: 10    Type: W    Bore diameter: d1 (Small diameter) - d2 (Large diameter)    M: Frictional coupling  
 Double element

## Dimension (SFS- □ W- □ M- □ C) Frictional Coupling/Tapered Shaft Supported

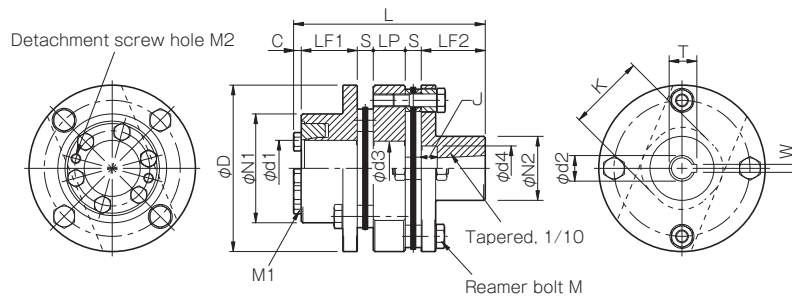

Model	Bore diameter	d1	d2	W <sub>+0.030</sub>	T <sub>+0.3</sub>	d4	J	D	N1	N2	L	LF1	LF2	LP	S	C	d3	K	M	M1	M2
SFS-06W	□ M-11C	12·14·15	11	4	12.2	18	9	68	40	40	78.8	25	25	12	6	4.8	24	30	8-M6 × 18	4-M5	2-M5
	15M-16C	15	16	5	17.3	28	10				93.8			40							
SFS-08W	□ M-16C	15·16·20·22	16	5	17.3	28	10	82	54	40	98.8	30	30	12	6	4.8	28	38	8-M6 × 20	4-M6	2-M6
SFS-09W	□ M-16C	25·28	16	5	17.3	28	10	94	58	40	112.8	30	30	22	8	4.8	32	42	8-M8 × 27	6-M6	2-M6

\* For a standard bore diameter, consult Miki Pulley as restrictions may apply to the permitted torque.  
 \* The nominal diameters of each bolt and tap are equal to the quantity minus the nominal diameter of the screw threads times the nominal length.  
 \* The machining tolerance for paired mounting shafts of the hub on the friction-coupled side is h7 (h6 or g6) class.

### How to Place an Order

### SFS-08W-20M-16C

Size: 8    Type: W    Bore diameter: d1 - d2    M: Frictional coupling    C: Tapered shaft supported  
 Double element

# SFS G Types Double Element/Floating Shaft Type

## Specifications

Model	Rated torque [N·m]	Misalignment			Max. rotation speed [min <sup>-1</sup> ]	Torsional stiffness [N·m/rad]	Axial stiffness [N/mm]	Moment of inertia [kg·m <sup>2</sup> ]	Mass [kg]
		Parallel [mm]	Angular [°]	Axial [mm]					
SFS-05G	20	0.5	1 (On one side)	± 1.2	20000	8000	21	0.20 × 10 <sup>-3</sup>	0.50
SFS-06G	40	0.5	1 (On one side)	± 1.6	16000	14000	22	0.55 × 10 <sup>-3</sup>	0.90
SFS-08G	80	0.5	1 (On one side)	± 2.0	13000	41000	30	1.50 × 10 <sup>-3</sup>	1.70
SFS-09G	180	0.6	1 (On one side)	± 2.4	12000	85000	61	2.90 × 10 <sup>-3</sup>	2.40
SFS-10G	250	0.6	1 (On one side)	± 2.8	10000	125000	80	4.60 × 10 <sup>-3</sup>	3.30
SFS-12G	450	0.8	1 (On one side)	± 3.2	8000	215000	98	11.80 × 10 <sup>-3</sup>	5.80
SFS-14G	800	0.9	1 (On one side)	± 3.6	7000	390000	156	21.20 × 10 <sup>-3</sup>	8.60
SFS-05G-C	15	0.5	1 (On one side)	± 1.2	20000	8000	21	0.20 × 10 <sup>-3</sup>	0.50
SFS-06G-C	30	0.5	1 (On one side)	± 1.6	16000	14000	22	0.55 × 10 <sup>-3</sup>	0.90
SFS-08G-C	60	0.5	1 (On one side)	± 2.0	13000	41000	30	1.50 × 10 <sup>-3</sup>	1.70
SFS-09G-C	135	0.6	1 (On one side)	± 2.4	12000	85000	61	2.90 × 10 <sup>-3</sup>	2.40
SFS-10G-C	190	0.6	1 (On one side)	± 2.8	10000	125000	80	4.60 × 10 <sup>-3</sup>	3.30
SFS-12G-C	340	0.8	1 (On one side)	± 3.2	8000	215000	98	11.80 × 10 <sup>-3</sup>	5.80
SFS-14G-C	600	0.9	1 (On one side)	± 3.6	7000	390000	156	21.20 × 10 <sup>-3</sup>	8.60
SFS-06G-□ M-□ M	40	0.5	1 (On one side)	± 1.6	5000	14000	22	0.55 × 10 <sup>-3</sup>	1.10
SFS-08G-□ M-□ M	80	0.5	1 (On one side)	± 2.0	5000	41000	30	1.56 × 10 <sup>-3</sup>	2.00
SFS-09G-□ M-□ M	180	0.6	1 (On one side)	± 2.4	5000	85000	61	3.10 × 10 <sup>-3</sup>	2.80
SFS-10G-□ M-□ M	250	0.6	1 (On one side)	± 2.8	5000	125000	80	4.70 × 10 <sup>-3</sup>	3.50
SFS-12G-□ M-□ M	450	0.8	1 (On one side)	± 3.2	5000	215000	98	12.10 × 10 <sup>-3</sup>	6.50
SFS-14G-35M-35M	580	0.9	1 (On one side)	± 3.6	5000	390000	156	25.31 × 10 <sup>-3</sup>	10.10
SFS-06G-□ M-11C	40	0.5	1 (On one side)	± 1.6	5000	14000	22	0.54 × 10 <sup>-3</sup>	1.00
SFS-06G-15M-16C	40	0.5	1 (On one side)	± 1.6	5000	14000	22	0.59 × 10 <sup>-3</sup>	1.10
SFS-08G-□ M-16C	80	0.5	1 (On one side)	± 2.0	5000	41000	30	1.47 × 10 <sup>-3</sup>	1.90
SFS-09G-□ M-16C	180	0.6	1 (On one side)	± 2.4	5000	85000	61	2.80 × 10 <sup>-3</sup>	2.60

\* Max. rotation speed does not take into account dynamic balance.  
 \* The moment of inertia and mass are measured for the maximum bore diameter.

## Dimension (SFS- □ G) Pilot Bore/Key or Set Screw

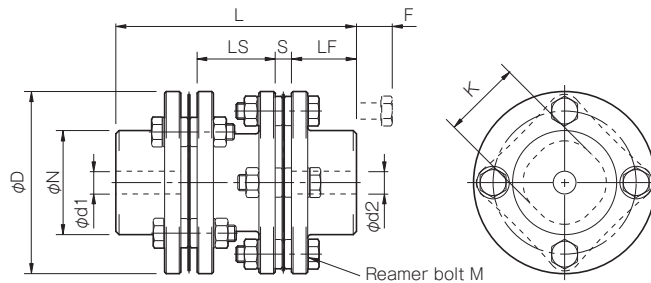

Unit [mm]

Model	d1 · d2			D	N	L	LF	LS	S	F	K	M
	Pilot bore	Min.	Max.									
SFS-05G	7	8	20	56	32	74	20	24	5	11	24	8-M5 × 22
SFS-06G	7	8	25	68	40	86	25	24	6	10	30	8-M6 × 25
SFS-08G	10	11	35	82	54	98	30	26	6	11	38	8-M6 × 29
SFS-09G	10	11	38	94	58	106	30	30	8	21	42	8-M8 × 36
SFS-10G	15	16	42	104	68	120	35	30	10	16	48	8-M8 × 36
SFS-12G	18	19	50	126	78	140	40	38	11	23	54	8-M10 × 45
SFS-14G	20	22	60	144	88	160	45	46	12	31	61	8-M12 × 54

\* Pilot bores are to be drilled into the part. See the standard hole-drilling standards of P.54 for information on bore drilling.  
 \* If you require a product with an LS dimension other than that above, contact Miki Pulley with your required dimension. Please contact Miki Pulley for assistance if LS ≥ 1000.  
 \* Please note that when the LS dimension exceeds 100 mm with the electroless nickel plating option (SFS-□ G-C), the insertion length of the shaft cannot exceed the LS dimension.  
 \* The nominal diameter of the reamer bolt M is equal to the quantity minus the nominal diameter of the screw threads times the nominal length.

How to Place an Order

**SFS-10G-C-25H-30H LS=500**

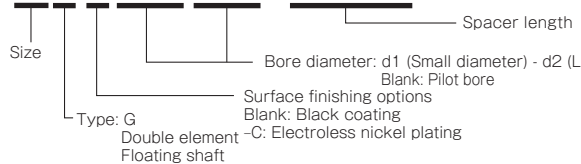

\* Use mm units for LS dimensions.  
 \* Leave blank for standard spacers.  
 Blank: Compliant with the old JIS standards (class 2) E9  
 H: Compliant with the new JIS standards H9  
 J: Compliant with the new JIS standards Js9  
 P: Compliant with the new JIS standards P9  
 N: Compliant with the new motor standards

COUPLINGS

ETP BUSHINGS

ELECTROMAGNETIC CLUTCHES & BRAKES

SPEED CHANGERS & REDUCERS

INVERTERS

LINEAR SHAFT DRIVES

TORQUE LIMITERS

ROSTA

SERIES

Metal Couplings	Metal Disc Couplings <b>SERVOFLEX</b>
	High-rigidity Couplings <b>SERVORIGID</b>
	Metal Slit Couplings <b>HELI-CAL</b>
	Metal Coil Spring Couplings <b>BAUMANNFLEX</b>
Pin Bushing Couplings	<b>PARAFLEX</b>
	Link Couplings <b>SCHMIDT</b>
Rubber and Plastic Couplings	Dual Rubber Couplings <b>STEPFLEX</b>
	Jaw Couplings <b>MIKI PULLEY STARFLEX</b>
	Jaw Couplings <b>SPRFLEX</b>
	Plastic Bellows Couplings <b>BELLOWFLEX</b>
	Rubber and Plastic Couplings <b>CENTAFLEX</b>

MODELS

SFC

SFS

SFF

SFM

SFH

Dimensions (SFS- □ G- □ M- □ M) Frictional Coupling

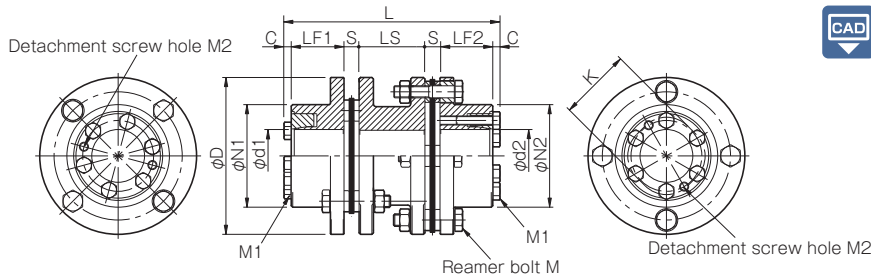

Unit [mm]

Model	Bore diameter	d1	d2	D	N1	N2	L	LF1	LF2	LS	S	C	K	M	M1	M2
SFS-06G	□ M-□ M	12·14·15	12·14·15	68	40	40	95.6	25	25	24	6	4.8	30	8-M6 × 18	4-M5	2-M5
SFS-08G	□ M-□ M	15·16·20·22	15·16·20·22	82	54	54	107.6	30	30	26	6	4.8	38	8-M6 × 20	4-M6	2-M6
SFS-09G	□ M-□ M	25·28	25·28	94	58	58	115.6	30	30	30	8	4.8	42	8-M8 × 27	6-M6	2-M6
	□ M-35M	25·28	35	68	68	123.6	38									
SFS-10G	□ M-□ M	25·28·30·35	25·28·30·35	104	68	68	129.6	35	35	30	10	4.8	48	8-M8 × 27	6-M6	2-M6
SFS-12G	□ M-□ M*1	30·35	30·35	126	78	78	150.6	40	40	38	11	5.3	54	8-M10 × 32	4-M8	2-M8
SFS-14G	35M-35M	35	35	144	88	88	170.6	45	45	46	12	5.3	61	8-M12 × 38	6-M8	2-M8

\* For a standard bore diameter, consult Miki Pulley as restrictions may apply to the permitted torque.  
 \* If you require a product with an LS dimension other than that above, contact Miki Pulley with your required dimension. Please contact Miki Pulley for assistance if LS ≥ 1000.  
 \* The nominal diameters of each bolt and tap are equal to the quantity minus the nominal diameter of the screw threads times the nominal length. The quantities for the pressure bolt M1 and detachment screw hole M2 are quantities for the hub on one side.  
 \* The rated torque of SFS-12G-30M-□ M in note \*1 is limited by the ø30 shaft coupling mechanism and is 380 N·m.  
 \* The machining tolerance for paired mounting shafts is h7 (h6 or g6) class. However, for a shaft diameter of 35 mm, the tolerance is  $^{+0.010}_{-0.025}$ .

How to Place an Order

SFS-10G-25M-30M LS=500

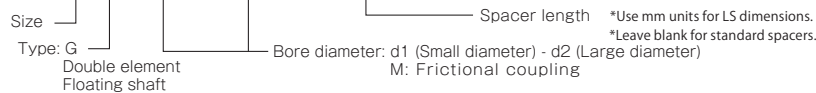

Dimension (SFS- □ G- □ M- □ C) Frictional Coupling/Tapered Shaft Supported

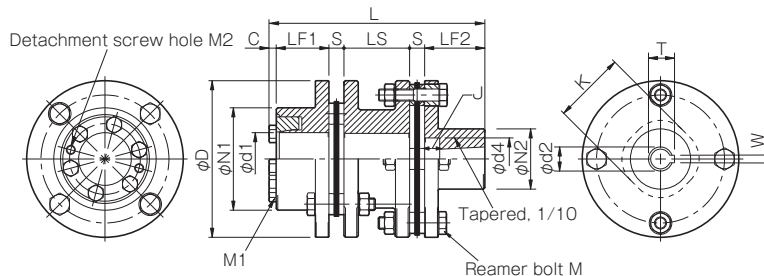

Unit [mm]

Model	Bore diameter	d1	d2	W $^{+0.030}$	T $^{+0.3}$	d4	J	D	N1	N2	L	LF1	LF2	LS	S	C	K	M	M1	M2
SFS-06G	□ M-11C	12·14·15	11	4	12.2	18	9	68	40	40	90.8	25	25	24	6	4.8	30	8-M6 × 18	4-M5	2-M5
	15M-16C	15	16	5	17.3	28	10	82	54	54	105.8	30	30	26	6	4.8	38	8-M6 × 20	4-M6	2-M6
SFS-08G	□ M-16C	15·16·20·22	16	5	17.3	28	10	82	54	54	112.8	30	30	26	6	4.8	38	8-M6 × 20	4-M6	2-M6
SFS-09G	□ M-16C	25·28	16	5	17.3	28	10	94	58	58	120.8	30	30	30	8	4.8	42	8-M8 × 27	6-M6	2-M6

\* For a standard bore diameter, consult Miki Pulley as restrictions may apply to the permitted torque.  
 \* If you require a product with an LS dimension other than that above, contact Miki Pulley with your required dimension. Please contact Miki Pulley for assistance if LS ≥ 1000.  
 \* The nominal diameters of each bolt and tap are equal to the quantity minus the nominal diameter of the screw threads times the nominal length.  
 \* The machining tolerance for paired mounting shafts of the hub on the friction-coupled side is h7 (h6 or g6) class.

How to Place an Order

SFS-08G-20M-16C LS=500

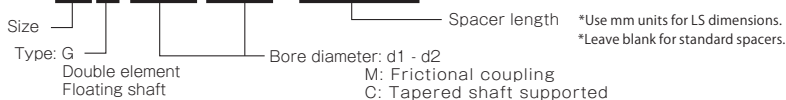



# SFS Models

## Standard Hole-Drilling Standards

- Positioning precision for keyway milling is determined by sight, so contact Miki Pulley when the keyway requires a positioning precision for a particular flange hub.
- Set screw positions are not on the same plane.
- The set screws are included with the product.
- Consult the technical documentation at the end of this volume for standard dimensions for bore drilling other than those given here.

### SFS W

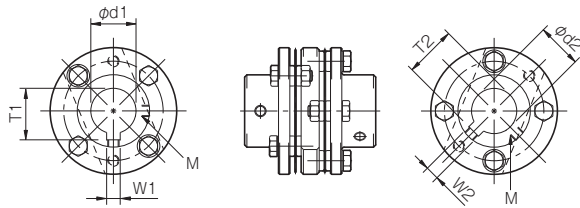

### SFH S

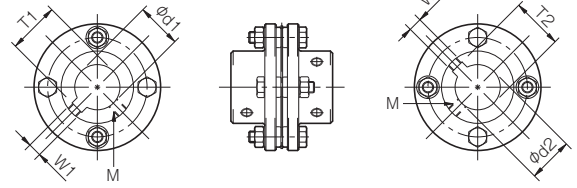

### SFH G

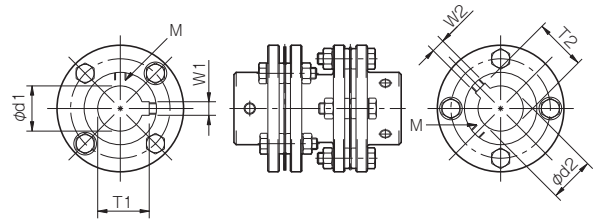

Unit [mm]

Models compliant with the old JIS standards (class 2)					Models compliant with the new JIS standards (H9)					Models compliant with the new JIS standards (Js9)					Models compliant with the new JIS standards (P9)				
Nominal bore diameter	Bore diameter [d1 · d2]	Keyway width [W1 · W2]	Keyway height [T1 · T2]	Set screw hole [M]	Nominal bore diameter	Bore diameter [d1 · d2]	Keyway width [W1 · W2]	Keyway height [T1 · T2]	Set screw hole [M]	Nominal bore diameter	Bore diameter [d1 · d2]	Keyway width [W1 · W2]	Keyway height [T1 · T2]	Set screw hole [M]	Nominal bore diameter	Bore diameter [d1 · d2]	Keyway width [W1 · W2]	Keyway height [T1 · T2]	Set screw hole [M]
Tolerance	H7, H8	E9	+0.3 0	—	Tolerance	H7, H8	H9	+0.3 0	—	Tolerance	H7, H8	Js9	+0.3 0	—	Tolerance	H7, H8	P9	+0.3 0	—
8	8 <sup>+0.022</sup> <sub>0</sub>	—	—	2-M4	8H	8 <sup>+0.022</sup> <sub>0</sub>	3 <sup>+0.025</sup> <sub>0</sub>	9.4	2-M4	8J	8 <sup>+0.022</sup> <sub>0</sub>	3 ± 0.0125	9.4	2-M4	8P	8 <sup>+0.022</sup> <sub>0</sub>	3 <sup>+0.006</sup> <sub>-0.031</sub>	9.4	2-M4
9	9 <sup>+0.022</sup> <sub>0</sub>	—	—	2-M4	9H	9 <sup>+0.022</sup> <sub>0</sub>	3 <sup>+0.025</sup> <sub>0</sub>	10.4	2-M4	9J	9 <sup>+0.022</sup> <sub>0</sub>	3 ± 0.0125	10.4	2-M4	9P	9 <sup>+0.022</sup> <sub>0</sub>	3 <sup>+0.006</sup> <sub>-0.031</sub>	10.4	2-M4
10	10 <sup>+0.022</sup> <sub>0</sub>	—	—	2-M4	10H	10 <sup>+0.022</sup> <sub>0</sub>	3 <sup>+0.025</sup> <sub>0</sub>	11.4	2-M4	10J	10 <sup>+0.022</sup> <sub>0</sub>	3 ± 0.0125	11.4	2-M4	10P	10 <sup>+0.022</sup> <sub>0</sub>	3 <sup>+0.006</sup> <sub>-0.031</sub>	11.4	2-M4
11	11 <sup>+0.018</sup> <sub>0</sub>	—	—	2-M4	11H	11 <sup>+0.018</sup> <sub>0</sub>	4 <sup>+0.030</sup> <sub>0</sub>	12.8	2-M4	11J	11 <sup>+0.018</sup> <sub>0</sub>	4 ± 0.0150	12.8	2-M4	11P	11 <sup>+0.018</sup> <sub>0</sub>	4 <sup>+0.012</sup> <sub>-0.042</sub>	12.8	2-M4
12	12 <sup>+0.018</sup> <sub>0</sub>	4 <sup>+0.050</sup> <sub>+0.020</sub>	13.5	2-M4	12H	12 <sup>+0.018</sup> <sub>0</sub>	4 <sup>+0.030</sup> <sub>0</sub>	13.8	2-M4	12J	12 <sup>+0.018</sup> <sub>0</sub>	4 ± 0.0150	13.8	2-M4	12P	12 <sup>+0.018</sup> <sub>0</sub>	4 <sup>+0.012</sup> <sub>-0.042</sub>	13.8	2-M4
14	14 <sup>+0.018</sup> <sub>0</sub>	5 <sup>+0.050</sup> <sub>+0.020</sub>	16.0	2-M4	14H	14 <sup>+0.018</sup> <sub>0</sub>	5 <sup>+0.030</sup> <sub>0</sub>	16.3	2-M4	14J	14 <sup>+0.018</sup> <sub>0</sub>	5 ± 0.0150	16.3	2-M4	14P	14 <sup>+0.018</sup> <sub>0</sub>	5 <sup>+0.012</sup> <sub>-0.042</sub>	16.3	2-M4
15	15 <sup>+0.018</sup> <sub>0</sub>	5 <sup>+0.050</sup> <sub>+0.020</sub>	17.0	2-M4	15H	15 <sup>+0.018</sup> <sub>0</sub>	5 <sup>+0.030</sup> <sub>0</sub>	17.3	2-M4	15J	15 <sup>+0.018</sup> <sub>0</sub>	5 ± 0.0150	17.3	2-M4	15P	15 <sup>+0.018</sup> <sub>0</sub>	5 <sup>+0.012</sup> <sub>-0.042</sub>	17.3	2-M4
16	16 <sup>+0.018</sup> <sub>0</sub>	5 <sup>+0.050</sup> <sub>+0.020</sub>	18.0	2-M4	16H	16 <sup>+0.018</sup> <sub>0</sub>	5 <sup>+0.030</sup> <sub>0</sub>	18.3	2-M4	16J	16 <sup>+0.018</sup> <sub>0</sub>	5 ± 0.0150	18.3	2-M4	16P	16 <sup>+0.018</sup> <sub>0</sub>	5 <sup>+0.012</sup> <sub>-0.042</sub>	18.3	2-M4
17	17 <sup>+0.018</sup> <sub>0</sub>	5 <sup>+0.050</sup> <sub>+0.020</sub>	19.0	2-M4	17H	17 <sup>+0.018</sup> <sub>0</sub>	5 <sup>+0.030</sup> <sub>0</sub>	19.3	2-M4	17J	17 <sup>+0.018</sup> <sub>0</sub>	5 ± 0.0150	19.3	2-M4	17P	17 <sup>+0.018</sup> <sub>0</sub>	5 <sup>+0.012</sup> <sub>-0.042</sub>	19.3	2-M4
18	18 <sup>+0.018</sup> <sub>0</sub>	5 <sup>+0.050</sup> <sub>+0.020</sub>	20.0	2-M4	18H	18 <sup>+0.018</sup> <sub>0</sub>	6 <sup>+0.030</sup> <sub>0</sub>	20.8	2-M5	18J	18 <sup>+0.018</sup> <sub>0</sub>	6 ± 0.0150	20.8	2-M5	18P	18 <sup>+0.018</sup> <sub>0</sub>	6 <sup>+0.012</sup> <sub>-0.042</sub>	20.8	2-M5
19	19 <sup>+0.021</sup> <sub>0</sub>	5 <sup>+0.050</sup> <sub>+0.020</sub>	21.0	2-M4	19H	19 <sup>+0.021</sup> <sub>0</sub>	6 <sup>+0.030</sup> <sub>0</sub>	21.8	2-M5	19J	19 <sup>+0.021</sup> <sub>0</sub>	6 ± 0.0150	21.8	2-M5	19P	19 <sup>+0.021</sup> <sub>0</sub>	6 <sup>+0.012</sup> <sub>-0.042</sub>	21.8	2-M5
20	20 <sup>+0.021</sup> <sub>0</sub>	5 <sup>+0.050</sup> <sub>+0.020</sub>	22.0	2-M4	20H	20 <sup>+0.021</sup> <sub>0</sub>	6 <sup>+0.030</sup> <sub>0</sub>	22.8	2-M5	20J	20 <sup>+0.021</sup> <sub>0</sub>	6 ± 0.0150	22.8	2-M5	20P	20 <sup>+0.021</sup> <sub>0</sub>	6 <sup>+0.012</sup> <sub>-0.042</sub>	22.8	2-M5
22	22 <sup>+0.021</sup> <sub>0</sub>	7 <sup>+0.061</sup> <sub>+0.025</sub>	25.0	2-M6	22H	22 <sup>+0.021</sup> <sub>0</sub>	6 <sup>+0.030</sup> <sub>0</sub>	24.8	2-M5	22J	22 <sup>+0.021</sup> <sub>0</sub>	6 ± 0.0150	24.8	2-M5	22P	22 <sup>+0.021</sup> <sub>0</sub>	6 <sup>+0.012</sup> <sub>-0.042</sub>	24.8	2-M5
24	24 <sup>+0.021</sup> <sub>0</sub>	7 <sup>+0.061</sup> <sub>+0.025</sub>	27.0	2-M6	24H	24 <sup>+0.021</sup> <sub>0</sub>	8 <sup>+0.036</sup> <sub>0</sub>	27.3	2-M6	24J	24 <sup>+0.021</sup> <sub>0</sub>	8 ± 0.0180	27.3	2-M6	24P	24 <sup>+0.021</sup> <sub>0</sub>	8 <sup>+0.015</sup> <sub>-0.051</sub>	27.3	2-M6
25	25 <sup>+0.021</sup> <sub>0</sub>	7 <sup>+0.061</sup> <sub>+0.025</sub>	28.0	2-M6	25H	25 <sup>+0.021</sup> <sub>0</sub>	8 <sup>+0.036</sup> <sub>0</sub>	28.3	2-M6	25J	25 <sup>+0.021</sup> <sub>0</sub>	8 ± 0.0180	28.3	2-M6	25P	25 <sup>+0.021</sup> <sub>0</sub>	8 <sup>+0.015</sup> <sub>-0.051</sub>	28.3	2-M6
28	28 <sup>+0.021</sup> <sub>0</sub>	7 <sup>+0.061</sup> <sub>+0.025</sub>	31.0	2-M6	28H	28 <sup>+0.021</sup> <sub>0</sub>	8 <sup>+0.036</sup> <sub>0</sub>	31.3	2-M6	28J	28 <sup>+0.021</sup> <sub>0</sub>	8 ± 0.0180	31.3	2-M6	28P	28 <sup>+0.021</sup> <sub>0</sub>	8 <sup>+0.015</sup> <sub>-0.051</sub>	31.3	2-M6
30	30 <sup>+0.021</sup> <sub>0</sub>	7 <sup>+0.061</sup> <sub>+0.025</sub>	33.0	2-M6	30H	30 <sup>+0.021</sup> <sub>0</sub>	8 <sup>+0.036</sup> <sub>0</sub>	33.3	2-M6	30J	30 <sup>+0.021</sup> <sub>0</sub>	8 ± 0.0180	33.3	2-M6	30P	30 <sup>+0.021</sup> <sub>0</sub>	8 <sup>+0.015</sup> <sub>-0.051</sub>	33.3	2-M6
32	32 <sup>+0.025</sup> <sub>0</sub>	10 <sup>+0.061</sup> <sub>+0.025</sub>	35.5	2-M8	32H	32 <sup>+0.025</sup> <sub>0</sub>	10 <sup>+0.036</sup> <sub>0</sub>	35.3	2-M8	32J	32 <sup>+0.025</sup> <sub>0</sub>	10 ± 0.0180	35.3	2-M8	32P	32 <sup>+0.025</sup> <sub>0</sub>	10 <sup>+0.015</sup> <sub>-0.051</sub>	35.3	2-M8
35	35 <sup>+0.025</sup> <sub>0</sub>	10 <sup>+0.061</sup> <sub>+0.025</sub>	38.5	2-M8	35H	35 <sup>+0.025</sup> <sub>0</sub>	10 <sup>+0.036</sup> <sub>0</sub>	38.3	2-M8	35J	35 <sup>+0.025</sup> <sub>0</sub>	10 ± 0.0180	38.3	2-M8	35P	35 <sup>+0.025</sup> <sub>0</sub>	10 <sup>+0.015</sup> <sub>-0.051</sub>	38.3	2-M8
38	38 <sup>+0.025</sup> <sub>0</sub>	10 <sup>+0.061</sup> <sub>+0.025</sub>	41.5	2-M8	38H	38 <sup>+0.025</sup> <sub>0</sub>	10 <sup>+0.036</sup> <sub>0</sub>	41.3	2-M8	38J	38 <sup>+0.025</sup> <sub>0</sub>	10 ± 0.0180	41.3	2-M8	38P	38 <sup>+0.025</sup> <sub>0</sub>	10 <sup>+0.015</sup> <sub>-0.051</sub>	41.3	2-M8
40	40 <sup>+0.025</sup> <sub>0</sub>	10 <sup>+0.061</sup> <sub>+0.025</sub>	43.5	2-M8	40H	40 <sup>+0.025</sup> <sub>0</sub>	12 <sup>+0.043</sup> <sub>0</sub>	43.3	2-M8	40J	40 <sup>+0.025</sup> <sub>0</sub>	12 ± 0.0215	43.3	2-M8	40P	40 <sup>+0.025</sup> <sub>0</sub>	12 <sup>+0.018</sup> <sub>-0.061</sub>	43.3	2-M8
42	42 <sup>+0.025</sup> <sub>0</sub>	12 <sup>+0.075</sup> <sub>+0.032</sub>	45.5	2-M8	42H	42 <sup>+0.025</sup> <sub>0</sub>	12 <sup>+0.043</sup> <sub>0</sub>	45.3	2-M8	42J	42 <sup>+0.025</sup> <sub>0</sub>	12 ± 0.0215	45.3	2-M8	42P	42 <sup>+0.025</sup> <sub>0</sub>	12 <sup>+0.018</sup> <sub>-0.061</sub>	45.3	2-M8
45	45 <sup>+0.025</sup> <sub>0</sub>	12 <sup>+0.075</sup> <sub>+0.032</sub>	48.5	2-M8	45H	45 <sup>+0.025</sup> <sub>0</sub>	14 <sup>+0.043</sup> <sub>0</sub>	48.8	2-M10	45J	45 <sup>+0.025</sup> <sub>0</sub>	14 ± 0.0215	48.8	2-M10	45P	45 <sup>+0.025</sup> <sub>0</sub>	14 <sup>+0.018</sup> <sub>-0.061</sub>	48.8	2-M10
48	48 <sup>+0.025</sup> <sub>0</sub>	12 <sup>+0.075</sup> <sub>+0.032</sub>	51.5	2-M8	48H	48 <sup>+0.025</sup> <sub>0</sub>	14 <sup>+0.043</sup> <sub>0</sub>	51.8	2-M10	48J	48 <sup>+0.025</sup> <sub>0</sub>	14 ± 0.0215	51.8	2-M10	48P	48 <sup>+0.025</sup> <sub>0</sub>	14 <sup>+0.018</sup> <sub>-0.061</sub>	51.8	2-M10
50	50 <sup>+0.025</sup> <sub>0</sub>	12 <sup>+0.075</sup> <sub>+0.032</sub>	53.5	2-M8	50H	50 <sup>+0.025</sup> <sub>0</sub>	14 <sup>+0.043</sup> <sub>0</sub>	53.8	2-M10	50J	50 <sup>+0.025</sup> <sub>0</sub>	14 ± 0.0215	53.8	2-M10	50P	50 <sup>+0.025</sup> <sub>0</sub>	14 <sup>+0.018</sup> <sub>-0.061</sub>	53.8	2-M10
55	55 <sup>+0.030</sup> <sub>0</sub>	15 <sup>+0.075</sup> <sub>+0.032</sub>	60.0	2-M10	55H	55 <sup>+0.030</sup> <sub>0</sub>	16 <sup>+0.043</sup> <sub>0</sub>	59.3	2-M10	55J	55 <sup>+0.030</sup> <sub>0</sub>	16 ± 0.0215	59.3	2-M10	55P	55 <sup>+0.030</sup> <sub>0</sub>	16 <sup>+0.018</sup> <sub>-0.061</sub>	59.3	2-M10
56	56 <sup>+0.030</sup> <sub>0</sub>	15 <sup>+0.075</sup> <sub>+0.032</sub>	61.0	2-M10	56H	56 <sup>+0.030</sup> <sub>0</sub>	16 <sup>+0.043</sup> <sub>0</sub>	60.3	2-M10	56J	56 <sup>+0.030</sup> <sub>0</sub>	16 ± 0.0215	60.3	2-M10	56P	56 <sup>+0.030</sup> <sub>0</sub>	16 <sup>+0.018</sup> <sub>-0.061</sub>	60.3	2-M10
60	60 <sup>+0.030</sup> <sub>0</sub>	15 <sup>+0.075</sup> <sub>+0.032</sub>	65.0	2-M10	60H	60 <sup>+0.030</sup> <sub>0</sub>	18 <sup>+0.043</sup> <sub>0</sub>	64.4	2-M10	60J	60 <sup>+0.030</sup> <sub>0</sub>	18 ± 0.0215	64.4	2-M10	60P	60 <sup>+0.030</sup> <sub>0</sub>	18 <sup>+0.018</sup> <sub>-0.061</sub>	64.4	2-M10

Models compliant with the new motor standards				
Nominal bore diameter	Bore diameter [d1 · d2]	Keyway width [W1 · W2]	Keyway height [T1 · T2]	Set screw hole [M]
Tolerance	G7, F7	H9	+0.3 0	—
14N	14 <sup>+0.024</sup> <sub>+0.006</sub>	5 <sup>+0.030</sup> <sub>0</sub>	16.3	2-M4
19N	19 <sup>+0.028</sup> <sub>+0.007</sub>	6 <sup>+0.030</sup> <sub>0</sub>	21.8	2-M5
24N	24 <sup>+0.028</sup> <sub>+0.007</sub>	8 <sup>+0.036</sup> <sub>0</sub>	27.3	2-M6
28N	28 <sup>+0.028</sup> <sub>+0.007</sub>	8 <sup>+0.036</sup> <sub>0</sub>	31.3	2-M6
38N	38 <sup>+0.050</sup> <sub>+0.025</sub>	10 <sup>+0.036</sup> <sub>0</sub>	41.3	2-M8
42N	42 <sup>+0.050</sup> <sub>+0.025</sub>	12 <sup>+0.043</sup> <sub>0</sub>	45.3	2-M8
48N	48 <sup>+0.050</sup> <sub>+0.025</sub>	14 <sup>+0.043</sup> <sub>0</sub>	51.8	2-M10
55N	55 <sup>+0.060</sup> <sub>+0.030</sub>	16 <sup>+0.043</sup> <sub>0</sub>	59.3	2-M10
60N	60 <sup>+0.060</sup> <sub>+0.030</sub>	18 <sup>+0.043</sup> <sub>0</sub>	64.4	2-M10

### Distance from Set Screw Edge

Model	Distance from set screw edge [mm]
SFS-05	7
SFS-06	9
SFS-08	10
SFS-09	10
SFS-10	12
SFS-12	12
SFS-14	15

## Centering and Finishing When Drilling Bores in Flange Hubs

Keep the following in mind when processing bore diameters in pilot-bore products.

### Centering

After adjusting the chuck so that runout of each flange hub is no more than the precision of the figure below, finish the inner diameter, guided by Figure A.

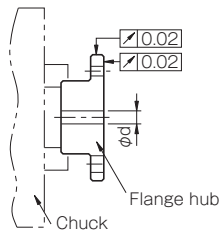

### Locking collar specifications

Finish as shown in Figure B if you are processing for a connection by means of locking collar.

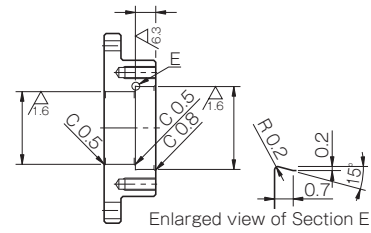

## Standard Bore Diameter Combinations

The standard bore diameter combinations for the types that use frictional coupling to mount on the shaft (SFS- □ S/W/G- □ M- □ M) are as follows.

SFS-06		Standard bore diameter d2 [mm]									
		12M	14M	15M	16M	20M	22M	25M	28M	30M	35M
Standard bore diameter d1 [mm]	12M	●	●	●							
	14M		●	●							
	15M			●							

SFS-08		Standard bore diameter d2 [mm]									
		12M	14M	15M	16M	20M	22M	25M	28M	30M	35M
Standard bore diameter d1 [mm]	15M			●	●	●	●				
	16M				●	●	●				
	20M					●	●				
	22M						●				

SFS-09		Standard bore diameter d2 [mm]									
		12M	14M	15M	16M	20M	22M	25M	28M	30M	35M
Standard bore diameter d1 [mm]	25M							●	●		●
	28M								●		●

SFS-10		Standard bore diameter d2 [mm]									
		12M	14M	15M	16M	20M	22M	25M	28M	30M	35M
Standard bore diameter d1 [mm]	25M							●	●	●	●
	28M								●	●	●
	30M									●	●
	35M										●

SFS-12		Standard bore diameter d2 [mm]									
		12M	14M	15M	16M	20M	22M	25M	28M	30M	35M
Standard bore diameter d1 [mm]	30M									380	380
	35M										●

SFS-14		Standard bore diameter d2 [mm]									
		12M	14M	15M	16M	20M	22M	25M	28M	30M	35M
Standard bore diameter d1 [mm]	35M										●

\* Bore diameters marked with ● and numbers are supported as standard bore diameter.

\* Bore diameters whose fields contain numbers are restricted in their rated torque by the holding power of the shaft connection component because the bore diameter is small. The numbers indicate the rated torque value [N·m].

\* Consult Miki Pulley regarding special arrangements for other bore diameters. For small bore diameters, consult Miki Pulley as restrictions may apply to the permitted torque.

## COUPLINGS

ETP BUSHINGS

ELECTROMAGNETIC CLUTCHES & BRAKES

SPEED CHANGERS & REDUCERS

INVERTERS

LINEAR SHAFT DRIVES

TORQUE LIMITERS

ROSTA

## SERIES

Metal Couplings	Metal Disc Couplings SERVOFLEX
	High-rigidity Couplings SERVORIGID
	Metal Slit Couplings HELI-CAL
Metal Couplings	Metal Coil Spring Couplings BAUMANNFLEX
	Pin Bushing Couplings PARAFLEX
Link Couplings	Link Couplings SCHMIDT
	Dual Rubber Couplings STEPFLEX
Rubber and Plastic Couplings	Jaw Couplings MIKI PULLEY STARFLEX
	Jaw Couplings SPRFLEX
	Plastic Bellows Couplings BELLOWFLEX
Rubber and Plastic Couplings	Rubber and Plastic Couplings CENTAFLEX

## MODELS

SFC

SFS

SFF

SFM

SFH

# SFS Models

## Items Checked for Design Purposes

### Special Items to Take Note of

You should note the following to prevent any problems.

- (1) Always be careful of parallel, angular, and axial misalignment.
- (2) Always tighten bolts with the specified torque.

### Precautions for Handling

SFS S/W/G types are delivered as components. Select whether to assemble by mounting flange hubs on each shaft and coupling shafts in both directions by mounting the element last, while centering, or to assemble by completing couplings first and then inserting them onto the shafts.

When using the assembly method that completes couplings first, take extra precautions when handling couplings. Subjecting assembled couplings to strong shocks may affect mounting accuracy and cause the parts to break during use.

- (1) Couplings are designed for use within an operating temperature range of -30° C to 120° C. Although the couplings are designed to be waterproof and oilproof, do not subject them to excessive amounts of water and oil as it may cause part deterioration.
- (2) Handle the element with care as it is made of a thin stainless steel metal disc, also making sure to be careful so as not to injure yourself.
- (3) For frictional coupling types, do not tighten up pressure bolts until after inserting the mounting shaft.

### Centering

#### Parallel misalignment ( $\epsilon$ )

Lock the dial gauge in place on one shaft and then measure the runout of the paired flange hub's outer periphery while rotating that shaft. Since couplings on which the elements (discs) are a set (SFS S types) do not allow parallel misalignment, get as close to zero as possible. For couplings that allow the entire length to be freely set (SFS G types), use the following formula to calculate allowable parallel misalignment.

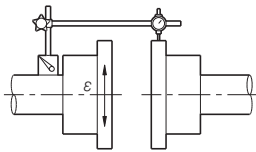

$$\epsilon = \tan \theta \times LG$$

$\epsilon$  : Allowable parallel misalignment  
 $\theta$  : 1°

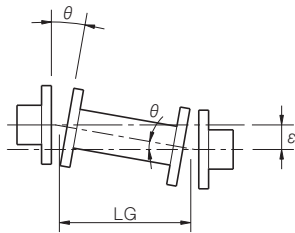

$$LG = LS + S$$

LS: Total length of spacer  
 S: Dimension of gap between flange hub and spacer

#### Angular deflection( $\theta$ )

Lock the dial gauge in place on one shaft and then measure the runout of the end surface near the paired flange hub's outer periphery while rotating that shaft.

Adjust runout B so that  $\theta \leq 1^\circ$  in the following formula.

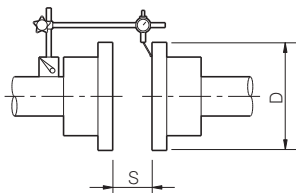

$$B = D \times \tan \theta$$

B: Runout  
 D: Flange hub outer diameter  
 $\theta$  : 1°

#### Axial displacement (S)

In addition, restrict the dimension between flange hub faces (S in the diagram) within the allowable error range for axial displacement with respect to a reference value. Note that the tolerance values were calculated based on the assumption that both the level of parallel misalignment and angular deflection are zero. Adjust to keep this value as low as possible.

\*On the SFS S, this is the dimension of the gap between two flange hubs. On the SFS W/G, dimension S is the gap between the flange hub and the spacer.

### Mounting (SFS S/W/G Types)

This assembly method mounts a flange hub on each shaft of the SFS S/W/G and couples shafts in both directions by mounting the element last, while centering.

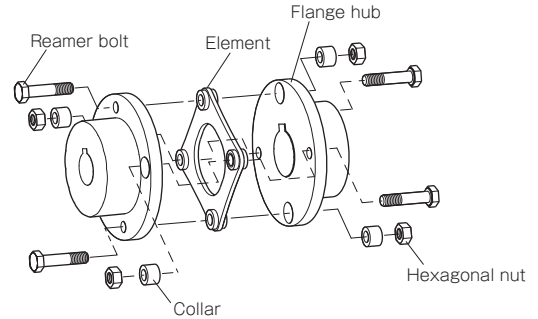

- (1) Remove any rust, dust, oil residue, etc. from inner diameter surfaces of the shaft and flange hubs. In particular, never allow oil or grease containing antifriction or other agent (molybdenum-, silicon-, or fluorine-based), which would dramatically affect the friction coefficient, to contact the surface.
- (2) Insert each shaft far enough into the flange hub that the paired mounting shaft touches the shaft along the entire length of the flange hub (LF dimension), as shown in the diagram below, and does not interfere with the elements, spacers or the other shaft.

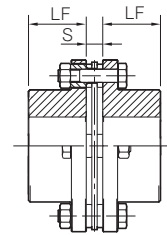

- (3) Mount the other flange hub on the paired mounting shaft as described in steps (1) and (2).
- (4) Keep the width of the dimension between flange hub faces (S dimension in the diagram) within the allowable error range for axial misalignment with respect to the reference value. Note that the tolerance values were calculated based on the assumption that both the level of parallel misalignment and angular deflection are zero. Adjust to keep this value as low as possible.

Coupling size	05	06	08	09	10	12	14
S [mm]	5	6	6	8	10	11	12

- (5) Insert the element into the gap between the two flange hubs, and then mount it with the reamer bolt for locking the element in place. Check that the element is not deformed. If it is, it may be under an axial force or there may be insufficient lubrication between the collar, bolt, and disc, so adjust to bring it to normal. The situation may be improved by applying a small amount of machine oil to the bearing surface of the reamer bolt. However, never use any oil or grease containing antifriction or other agent (molybdenum-, silicon-, or fluorine-based) which would dramatically affect the friction coefficient.

- (6) Use a calibrated torque wrench to tighten all the reamer bolts to the tightening torques of the table below.

Coupling size	05	06	08	09	10	12	14
Reamer bolt size	M5	M6	M6	M8	M8	M10	M12
Tightening torque [N·m] Black oxide finish (standard) specification	8	14	14	34	34	68	118
Tightening torque [N·m] Electroless nickel plating [° C] specification	6	11	11	26	26	51	90

## Mounting (SFS S/W/G-□ M-□ M Types)

This assembly method mounts a flange hub on each shaft of the SFS S/W/G-□ M-□ M type and couples both shafts by mounting the element last while centering.

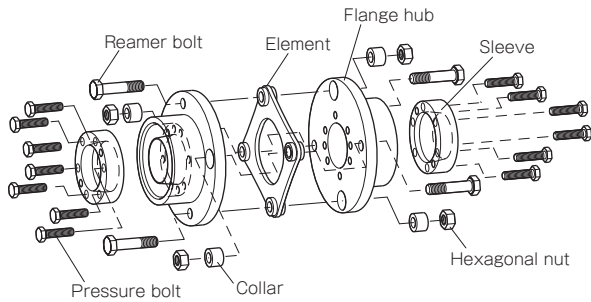

- (1) Loosen the pressure bolts of the flange hubs, check that the sleeve can move freely, and then remove any rust, dust, oil residue, etc. from the inner diameter surfaces of the shaft and flange hubs. In particular, never allow oil or grease containing antifriction or other agent (molybdenum-, silicon-, or fluorine-based), which would dramatically affect the friction coefficient, to contact the surface.
- (2) Insert each shaft far enough into the flange hub that the paired mounting shaft touches the shaft along the entire length of the flange hub (LF dimension), as shown in the diagram below, and does not interfere with the elements, spacers or the other shaft. Then, holding them in place, tighten the pressure bolts evenly, a little at a time on the diagonal, following the tightening sequence shown in the figure below.

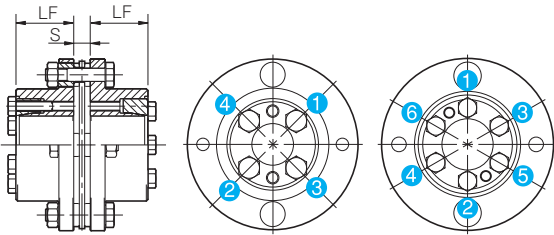

- (3) Mount the other flange hub on the paired mounting shaft as described in steps (1) and (2).
- (4) Keep the width of the dimension between flange hub faces (S dimension in the diagram) within the allowable error range for axial misalignment with respect to the reference value. Note that the tolerance values were calculated based on the assumption that both the level of parallel misalignment and angular deflection are zero. Adjust to keep this value as low as possible.

Coupling size	06	08	09	10	12	14
S [mm]	6	6	8	10	11	12

- (5) Insert the element into the gap between the two flange hubs, and then mount it with the reamer bolt for locking the element in place. Check that the element is not deformed. If it is, it may be under an axial force or there may be insufficient lubrication between the collar, bolt, and disc, so adjust to bring it to normal. The situation may be improved by applying a small amount of machine oil to the bearing surface of the reamer bolt. However, never use any oil or grease containing antifriction or other agent (molybdenum-, silicon-, or fluorine-based) which would dramatically affect the friction coefficient.

- (6) Use a calibrated torque wrench to tighten all the reamer and pressure bolts to the tightening torques of the table below.

Coupling size	06	08	09	10	12	14
Reamer bolt size	M6	M6	M8	M8	M10	M12
Tightening torque [N·m]	14	14	34	34	68	118
Pressure bolt size	M5	M6	M6	M6	M8	M8
Tightening torque [N·m]	8	14	14	14	34	34

## Mounting (When Mounted After Coupling Is Completed)

This SFS S/W/G type assembly method first completes the coupling and then inserts it onto the shaft.

- (1) Remove any rust, dust, oil or the like from the inner diameter surfaces of the shaft and flange hubs. In particular, never allow oil or grease containing antifriction or other agent (molybdenum-, silicon-, or fluorine-based), which would dramatically affect the friction coefficient, to contact the surface.  
For types that use frictional coupling, loosen the flange hub's pressure bolt and check that the sleeve can move freely.

- (2) Be careful when inserting the couplings into the shaft so as not to apply excessive force of compression or tensile force to the element.  
Be particularly careful not to mistakenly apply excessive compression force when inserting couplings into the paired shaft after mounting on one shaft.

- (3) For frictional coupling types, with the pressure bolts loosened, make sure that couplings move gently in the axial and rotational directions.  
Readjust the centering of the two shafts if the couplings fail to move smoothly enough.

- (4) Insert each shaft far enough into the flange hub that the paired mounting shaft touches the shaft along the entire length of the flange hub (LF dimension), as shown in the diagram below. Then position it so that it does not interfere with the elements, spacers or the other shaft and lock it in place. For frictional coupling types, tighten the pressure bolts evenly, a little at a time on the diagonal, following the tightening sequence shown in the figure below.

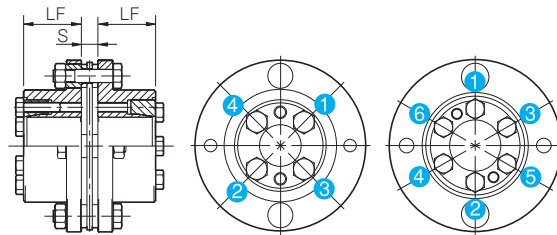

- (5) Keep the width of the dimension between flange hub faces (S dimension in the diagram) within the allowable error range for axial misalignment with respect to the reference value. Note that the tolerance values were calculated based on the assumption that both the level of parallel misalignment and angular deflection are zero. Adjust to keep this value as low as possible.

Coupling size	05	06	08	09	10	12	14
S [mm]	5	6	6	8	10	11	12

- (6) Use a calibrated torque wrench to tighten all the pressure bolts to the appropriate tightening torques of the table below.

Coupling size	06	08	09	10	12	14
Pressure bolt size	M5	M6	M6	M6	M8	M8
Tightening torque [N·m]	8	14	14	14	34	34

COUPLINGS

ETP BUSHINGS

ELECTROMAGNETIC CLUTCHES & BRAKES

SPEED CHANGERS & REDUCERS

INVERTERS

LINEAR SHAFT DRIVES

TORQUE LIMITERS

ROSTA

SERIES

Metal Couplings	Metal Disc Couplings	SERVOFLEX
	High-rigidity Couplings	SERVORIGID
	Metal Slit Couplings	HELI-CAL
	Metal Coil Spring Couplings	BAUMANNFLEX
Pin Bushing Couplings		PARAFLEX
	Link Couplings	SCHMIDT
Rubber and Plastic Couplings	Dual Rubber Couplings	STEPFLEX
	Jaw Couplings	MIKI PULLEY STARFLEX
	Jaw Couplings	SPRFLEX
	Plastic Bellows Couplings	BELLOWFLEX
	Rubber and Plastic Couplings	CENTAFLEX

MODELS

SFC

SFS

SFF

SFM

SFH

# SFS Models

## Items Checked for Design Purposes

### Removal

- (1) Check to confirm that there is no torque or axial direction load being applied to the coupling. There may be cases where a torque is applied to the coupling, particularly when the safety brake is being used. Make sure to verify that this is not occurring before removing parts.
- (2) Loosen all the pressure bolts placing pressure on the sleeve until the gap between bearing seat and sleeve is about 2 mm.

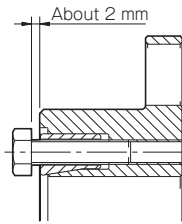

In the case of a tapered coupling system that tightens a pressure bolt from the axial direction, the sleeve will be self-locking, so the coupling between flange hub and shaft cannot be released simply by loosening the pressure bolt. (Note that in some cases, a coupling can be released by loosening a pressure bolt.)

For that reason, when designing couplings, a space must be installed for inserting a detachment screw.

If there is no space in the axial direction, consult Miki Pulley.

- (3) Pull out two of the pressure bolts loosened in step (2), insert them into detachment screw holes at two locations on the sleeve, and tighten them alternately, a little at a time. The coupling between the flange hub and shaft will be released.

### SFS-S/W/G type

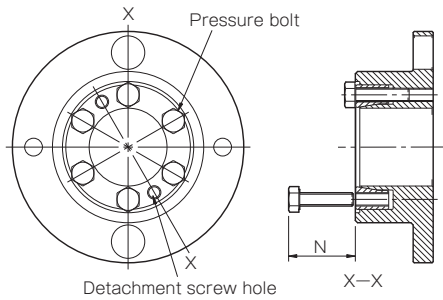

Coupling size	06	08	09	10	12	14
Nominal diameter of pressure bolt × Length	M5 × 20	M6 × 24	M6 × 24	M6 × 24	M8 × 25	M8 × 25
Recommended N dimension (mm)	26	30	30	30	31.5	31.5

### Limit Rotation Speed

For SFS G long spacer types, the speed at which the coupling can be used will vary with the length of spacer selected. Use the following table to confirm that the speed you will use is at or below the limit rotation speed. When a max. rotation speed is set for a specific type, that speed is the upper limit.

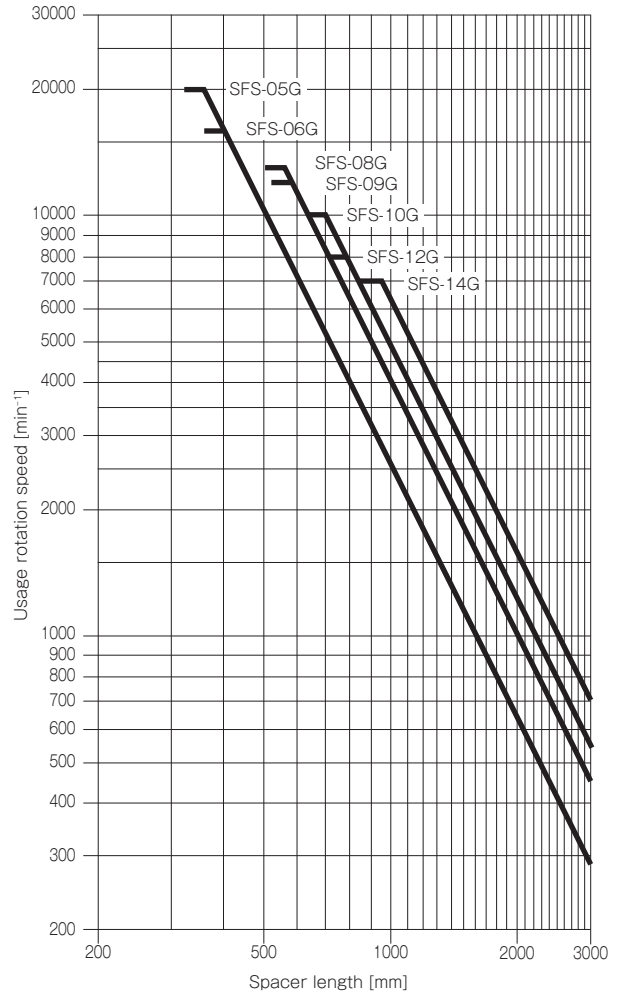

### Points to Consider Regarding the Feed Screw System

#### Servo motor oscillation

Gain adjustment on the servo motor may cause the servo motor to oscillate.

Oscillation in the servo motor during operation can cause problems particularly with the overall natural frequency and electrical control systems of the feed screw system.

In order for these issues to be resolved, the torsional stiffness for the coupling and feed screw section and the moment of inertia and other characteristics for the system overall will need to be adjusted and the torsional natural frequency for the mechanical system raised or the tuning function (filter function) for the electrical control system in the servo motor adjusted during the design stage.

#### Stepper motor resonance

Stepper motors resonate at certain rotation speeds due to the pulsation frequency of the stepper motor and the torsional natural frequency of the system as a whole. To avoid resonance, either the resonant rotation speed must be simply skipped or the torsional natural frequency considered at the design stage.

Please contact Miki Pulley with any questions regarding servo motor oscillation or stepper motor resonance.

## How to Find the Natural Frequency of a Feed Screw System

- Select a coupling based on the nominal and maximum torque of the servo motor or stepper motor.
- Find the overall natural frequency,  $N_f$ , from the torsional stiffness of the coupling and feed screw,  $\kappa$ , the moment of inertia of driving side,  $J_1$ , and the moment of inertia of driven side,  $J_2$ , for the feed screw system shown below.

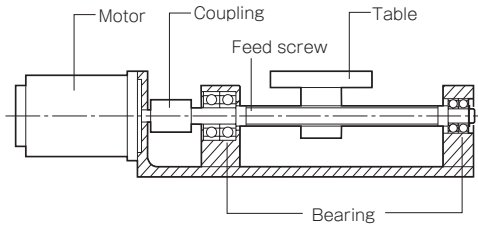

$$N_f = \frac{1}{2\pi} \sqrt{\kappa \left( \frac{1}{J_1} + \frac{1}{J_2} \right)}$$

- $N_f$ : Overall natural frequency of a feed screw system [Hz]
- $\kappa$ : Torsional stiffness of the coupling and feed screw [N-m/rad]
- $J_1$ : Moment of inertia of driving side [kg-m<sup>2</sup>]
- $J_2$ : Moment of inertia of driven side [kg-m<sup>2</sup>]

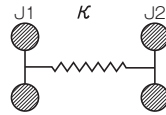

## Selection Procedures

- Find the torque,  $T_a$ , applied to the coupling using the output capacity,  $P$ , of the driver and the usage rotation speed,  $n$ .

$$T_a \text{ [N}\cdot\text{m]} = 9550 \times \frac{P \text{ [kW]}}{n \text{ [min}^{-1}\text{]}}$$

- Determine the factor  $\kappa$  from the load properties, and find the corrected torque,  $T_d$ , applied to the coupling.

$$T_d = T_a \times K \text{ (Refer to the table below for values)}$$

Load properties	Constant	Vibrations: Small	Vibrations: Medium	Vibrations: Large
$K$	1.0	1.25	1.75	2.25

For servo motor drive, multiply the maximum torque,  $T_s$ , by the usage factor  $K = 1.2$  to  $1.5$ .

$$T_d = T_s \times (1.2 \text{ to } 1.5)$$

- Set the size so that the rated coupling torque,  $T_n$ , is higher than the corrected torque,  $T_d$ .

$$T_n \geq T_d$$

- The rated torque of the coupling may be limited by the bore diameter of the coupling. See the table showing the bore diameters that limit rated torque.

- Check that the mount shaft is no larger than the maximum bore diameter of the coupling.

Contact Miki Pulley for assistance with any device experiencing extreme periodic vibrations.

## Mounting Example

### SFS S-□ M-□ M

These are combinations of multiple high-precision frictional-coupling flange hubs. When these are used, shafts can be connected to each other after couplings are finished.

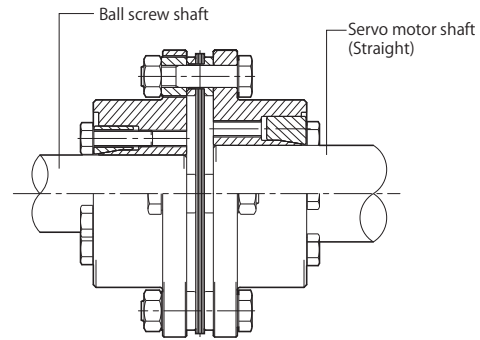

### SFS S-□ M-□ C

These are combinations of high-precision frictional-coupling flange hubs with flange hubs for tapered shafts. They are assembled by tightening the end of the servo motor shaft with a nut.

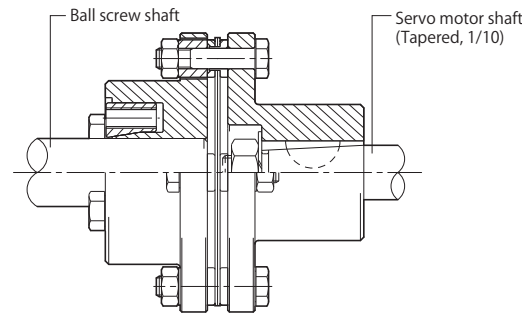

### SFS S

The example shows a pilot-bore type of flange hub processed for a POSI-LOCK PSL-K, a shaft lock made by Miki Pulley, and connected to a straight shaft.

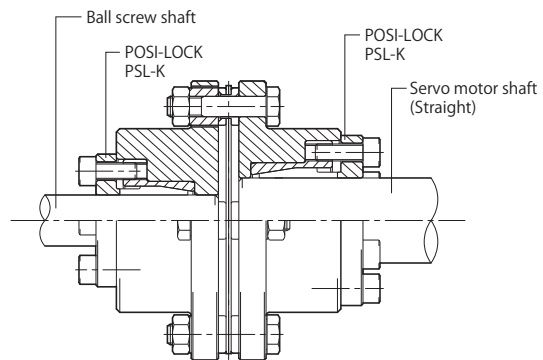

## COUPLINGS

### ETP BUSHINGS

### ELECTROMAGNETIC CLUTCHES & BRAKES

### SPEED CHANGERS & REDUCERS

### INVERTERS

### LINEAR SHAFT DRIVES

### TORQUE LIMITERS

### ROSTA

## SERIES

Metal Couplings	Metal Disc Couplings SERVOFLEX
	High-rigidity Couplings SERVORIGID
	Metal Slit Couplings HELI-CAL
	Metal Coil Spring Couplings BAUMANNFLEX
	Pin Bushing Couplings PARAFLEX
Rubber and Plastic Couplings	Link Couplings SCHMIDT
	Dual Rubber Couplings STEPFLEX
	Jaw Couplings MIKI PULLEY STARFLEX
	Jaw Couplings SPRFLEX
	Plastic Bellows Couplings BELLOWFLEX
	Rubber and Plastic Couplings CENTAFLEX

## MODELS

### SFC

### SFS

### SFF

### SFM

### SFH

# SFF SS Types Single Element/Clamping

## Specifications

Model	Rated torque [N·m]	Misalignment			Max. rotation speed [min <sup>-1</sup> ]	Torsional stiffness [N·m/rad]	Axial stiffness [N/mm]	Moment of inertia [kg·m <sup>2</sup> ]	Mass [kg]
		Parallel [mm]	Angular [°]	Axial [mm]					
SFF-040SS-□B-□B-8N	8	0.02	1	± 0.2	18000	15000	174	0.03 × 10 <sup>-3</sup>	0.17
SFF-040SS-□B-□B-12N	12	0.02	1	± 0.2	18000	15000	174	0.03 × 10 <sup>-3</sup>	0.17
SFF-050SS-□B-□B-25N	25	0.02	1	± 0.3	18000	32000	145	0.10 × 10 <sup>-3</sup>	0.36
SFF-060SS-□B-□B-60N	60	0.02	1	± 0.3	18000	104000	399	0.22 × 10 <sup>-3</sup>	0.52
SFF-060SS-□B-□B-80N	80	0.02	1	± 0.3	18000	104000	399	0.23 × 10 <sup>-3</sup>	0.49
SFF-070SS-□B-□B-90N	90	0.02	1	± 0.5	18000	240000	484	0.40 × 10 <sup>-3</sup>	0.72
SFF-070SS-□B-□B-100N	100	0.02	1	± 0.5	18000	240000	484	0.42 × 10 <sup>-3</sup>	0.67
SFF-080SS-□B-□B-150N	150	0.02	1	± 0.5	17000	120000	96	0.79 × 10 <sup>-3</sup>	1.04
SFF-080SS-□B-□B-200N	200	0.02	1	± 0.5	17000	310000	546	1.25 × 10 <sup>-3</sup>	1.40
SFF-090SS-□B-□B-250N	250	0.02	1	± 0.6	15000	520000	321	1.54 × 10 <sup>-3</sup>	1.62
SFF-090SS-□B-□B-300N	300	0.02	1	± 0.6	15000	520000	321	1.58 × 10 <sup>-3</sup>	1.53
SFF-100SS-□B-□B-450N	450	0.02	1	± 0.65	13000	740000	540	3.27 × 10 <sup>-3</sup>	2.53
SFF-120SS-□B-□B-600N	600	0.02	1	± 0.8	11000	970000	360	6.90 × 10 <sup>-3</sup>	3.78

\* Max. rotation speed does not take into account dynamic balance.  
 \* Torsional stiffness values given are measured values for the element alone.  
 \* The moment of inertia and mass are measured for the maximum bore diameter.

## Dimensions

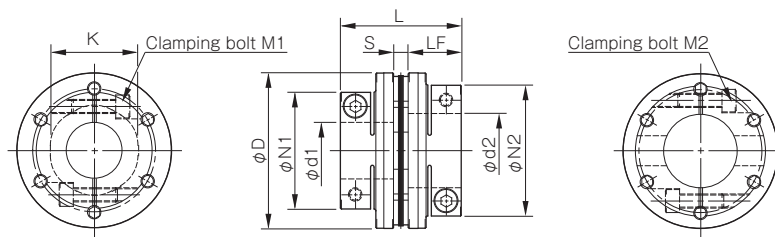

Model	d1 [mm]	d2 [mm]	D [mm]	L [mm]	N1 · N2 [mm]	LF [mm]	S [mm]	K [mm]	M1 · M2 Qty · Nominal dia.	M1 · M2 Tightening torque [N · m]
SFF-040SS-□B-□B-8N	8 · 9 · 9.525	8 · 9 · 9.525 · 10 · 11 · 12 · 14 · 15 · 16	38	38.9	33	17.5	3.9	17	2-M4	3.4
SFF-040SS-□B-□B-12N	10 · 11 · 12 · 14 · 15 · 16	10 · 11 · 12 · 14 · 15 · 16	38	38.9	33	17.5	3.9	17	2-M4	3.4
SFF-050SS-□B-□B-25N	10 · 11 · 12 · 14 · 15 · 16 · 17 · 18 · 19	10 · 11 · 12 · 14 · 15 · 16 · 17 · 18 · 19	48	48.4	42	21.5	5.4	20	2-M5	7
SFF-060SS-□B-□B-60N	12 · 14 · 15 · 16 · 17 · 18 · 19	12 · 14 · 15 · 16 · 17 · 18 · 19 · 20 · 22	58	53.4	44	24	5.4	32	2-M6	14
	—	24 · 25 · 28			48				2-M5	7
	—	30			52				2-M6	14
SFF-060SS-□B-□B-80N	20 · 22	20 · 22	58	53.4	44	24	5.4	32	2-M6	14
	24 · 25 · 28	24 · 25 · 28			48				2-M5	7
SFF-070SS-□B-□B-90N	18 · 19	18 · 19 · 20 · 22 · 24 · 25	68	55.9	47	25	5.9	38	2-M6	14
	—	28 · 30 · 32 · 35			56					
SFF-070SS-□B-□B-100N	20 · 22 · 24 · 25	20 · 22 · 24 · 25	68	55.9	47	25	5.9	38	2-M6	14
	28 · 30 · 32 · 35	28 · 30 · 32 · 35			56					
SFF-080SS-□B-□B-150N	22 · 24 · 25	22 · 24 · 25	78	68.3	53	30	8.3	37	2-M8	34
	28 · 30 · 32 · 35	28 · 30 · 32 · 35			56				2-M6	14
	22 · 24 · 25	22 · 24 · 25			53					
SFF-080SS-□B-□B-200N	28 · 30 · 32 · 35	28 · 30 · 32 · 35	78	67.7	70	30	7.7	42	2-M8	34
	38	38			74					
	25 · 28	25 · 28 · 30 · 32			66					
SFF-090SS-□B-□B-250N	—	35 · 38 · 40 · 42	88	68.3	74	30	8.3	50	2-M8	34
	30 · 32	30 · 32			66					
SFF-090SS-□B-□B-300N	35 · 38 · 40 · 42	35 · 38 · 40 · 42	88	68.3	74	30	8.3	50	2-M8	34
	—	—			74					
SFF-100SS-□B-□B-450N	32 · 35 · 38 · 40 · 42 · 45 · 48	32 · 35 · 38 · 40 · 42 · 45 · 48	98	90.2	84	40	10.2	56	2-M10	68
SFF-120SS-□B-□B-600N	32 · 35 · 38 · 40 · 42 · 45	32 · 35 · 38 · 40 · 42 · 45	118	90.2	84	40	10.2	68	2-M10	68
	48 · 50 · 55	48 · 50 · 55			100					

\* Nominal diameter of clamping bolt M1/M2 is given as number of bolts · nominal diameter, and the number is the number for one hub.

## COUPLINGS

ETP BUSHINGS

ELECTROMAGNETIC CLUTCHES & BRAKES

SPEED CHANGERS & REDUCERS

INVERTERS

LINEAR SHAFT DRIVES

TORQUE LIMITERS

ROSTA

## SERIES

Metal Couplings	Metal Disc Couplings <b>SERVOFLEX</b>	
	High-rigidity Couplings <b>SERVORIGID</b>	
	Metal Slit Couplings <b>HELI-CAL</b>	
	Metal Coil Spring Couplings <b>BAUMANNFLEX</b>	
	Pin Bushing Couplings <b>PARAFLEX</b>	
	Link Couplings <b>SCHMIDT</b>	
	Rubber and Plastic Couplings	Dual Rubber Couplings <b>STEPFLEX</b>
		Jaw Couplings <b>MIKI PULLEY STARFLEX</b>
		Jaw Couplings <b>SPRFLEX</b>
		Plastic Bellows Couplings <b>BELLOWFLEX</b>
Rubber and Plastic Couplings <b>CENTAFLEX</b>		

## Standard Bore Diameter

Model	Nominal diameter	Standard bore diameter d1 · d2 [mm]																										
		8	9	9.525	10	11	12	14	15	16	17	18	19	20	22	24	25	28	30	32	35	38	40	42	45	48	50	55
SFF-040SS-□B-□B-8N	d1	●	●	●																								
	d2	●	●	●	●	●	●	●	●	●																		
SFF-040SS-□B-□B-12N	d1				●	●	●	●	●	●																		
	d2				●	●	●	●	●	●	●																	
SFF-050SS-□B-□B-25N	d1				●	●	●	●	●	●	●	●																
	d2				●	●	●	●	●	●	●	●	●															
SFF-060SS-□B-□B-60N	d1							●	●	●	●	●	●															
	d2							●	●	●	●	●	●	●														
SFF-060SS-□B-□B-80N	d1													●	●	●	●	●										
	d2													●	●	●	●	●	●									
SFF-070SS-□B-□B-90N	d1																●	●										
	d2																●	●	●	●	●							
SFF-070SS-□B-□B-100N	d1																											
	d2																											
SFF-080SS-□B-□B-150N	d1																											
	d2																											
SFF-080SS-□B-□B-200N	d1																											
	d2																											
SFF-090SS-□B-□B-250N	d1																											
	d2																											
SFF-090SS-□B-□B-300N	d1																											
	d2																											
SFF-100SS-□B-□B-450N	d1																											
	d2																											
SFF-120SS-□B-□B-600N	d1																											
	d2																											

\* The bore diameters marked with ● are supported as standard bore diameter.

## Tapered shaft supported Option

Model	Rated torque [N · m]	Moment of inertia [kg · m <sup>2</sup> ]	Mass [kg]
SFF-040SS-□B-11CN-8N	8	0.03 × 10 <sup>-3</sup>	0.20
SFF-040SS-□B-11CN-12N	12	0.03 × 10 <sup>-3</sup>	0.18
SFF-050SS-□B-14CN-25N	25	0.09 × 10 <sup>-3</sup>	0.36
SFF-050SS-□B-16CN-25N	25	0.10 × 10 <sup>-3</sup>	0.41
SFF-060SS-□B-16CN-60N	60	0.18 × 10 <sup>-3</sup>	0.54
SFF-060SS-□B-16CN-80N	80	0.19 × 10 <sup>-3</sup>	0.52

\* The moment of inertia and mass are measured for the maximum bore diameter.

\* For other "Specifications", see "Specifications" for Single Element Clamping.

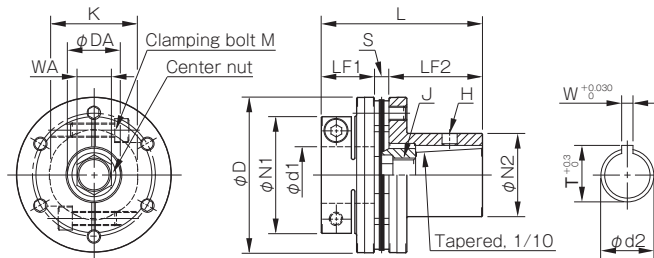

Model	d1 [mm]	d2 [mm]	W [mm]	T [mm]	D [mm]	L [mm]	N1 [mm]	N2 [mm]	LF1 [mm]	LF2 [mm]	S [mm]	K [mm]	H [mm]	M Qty - Nominal dia.	MTightening torque [N · m]	DA [mm]	WA [mm]	J Nominal × pitch	J Tightening torque [N · m]	
SFF-040SS-□B-11CN-8N	8 ~ 9.525	11	4	12.2	38	46.4	33	22	17.5	25	3.9	17	5.1	2-M4	3.4	12	6	M6 × 1.0	10	
SFF-040SS-□B-11CN-12N	10 ~ 16	11	4	12.2	38	46.4	33	22	17.5	25	3.9	17	5.1	2-M4	3.4	12	6	M6 × 1.0	10	
SFF-050SS-□B-14CN-25N	10 ~ 19	14	4	15.1	48	56.9	42	27.5	21.5	30	5.4	20	5.1	2-M5	7	15	8	M8 × 1.0	20	
SFF-050SS-□B-16CN-25N	10 ~ 19	16	5	17.3	48	67.9	42	29.5	21.5	41	5.4	20	6.8	2-M5	7	16	10	M10 × 1.25	30	
SFF-060SS-□B-16CN-60N	12 ~ 19	16	5	17.3	58	70.4	44	29.5	24	41	5.4	32	6.8	2-M6	14	16	10	M10 × 1.25	30	
	20 ~ 22						44							2-M6	14					
	24 ~ 28	16	5	17.3	58	70.4	48	29.5	24	41	5.4	32	6.8	2-M5	7	16	10	M10 × 1.25	30	
SFF-060SS-□B-16CN-80N	30						52													

## MODELS

SFC

SFS

SFF

SFM

SFH

## How to Place an Order

### SFF-080SS-25BK-30BK-200N

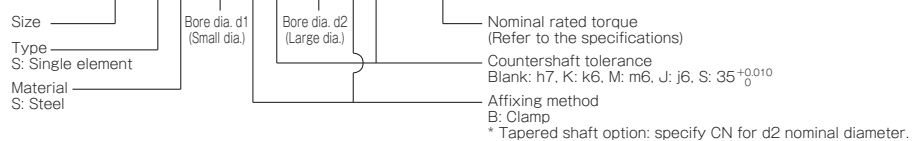



# SFF SS Types Single Element/Wedge Coupling

## Specifications

Model	Rated torque [N·m]	Misalignment			Max. rotation speed [min <sup>-1</sup> ]	Torsional stiffness [N·m/rad]	Axial stiffness [N/mm]	Moment of inertia [kg·m <sup>2</sup> ]	Mass [kg]
		Parallel [mm]	Angular [°]	Axial [mm]					
SFF-070SS-□K-□K-100N	100	0.02	1	± 0.5	18000	240000	484	0.66 × 10 <sup>-3</sup>	0.92
SFF-080SS-□K-□K-150N	150	0.02	1	± 0.5	17000	120000	96	1.21 × 10 <sup>-3</sup>	1.03
SFF-080SS-□K-□K-200N	200	0.02	1	± 0.5	17000	310000	546	1.11 × 10 <sup>-3</sup>	1.26
SFF-090SS-□K-□K-300N	300	0.02	1	± 0.6	15000	520000	321	1.75 × 10 <sup>-3</sup>	1.48
SFF-100SS-□K-□K-450N	450	0.02	1	± 0.65	13000	740000	540	2.56 × 10 <sup>-3</sup>	1.87
SFF-120SS-□K-□K-600N	600	0.02	1	± 0.8	11000	970000	360	5.33 × 10 <sup>-3</sup>	2.50
SFF-140SS-□K-□K-800N	800	0.02	1	± 1.0	10000	1400000	360	10.28 × 10 <sup>-3</sup>	4.66
SFF-140SS-□K-□K-1000N	1000	0.02	1	± 1.0	10000	1400000	360	14.70 × 10 <sup>-3</sup>	5.01

\* Max. rotation speed does not take into account dynamic balance.  
 \* Torsional stiffness values given are measured values for the element alone.  
 \* The moment of inertia and mass are measured for the maximum bore diameter.

## Dimensions

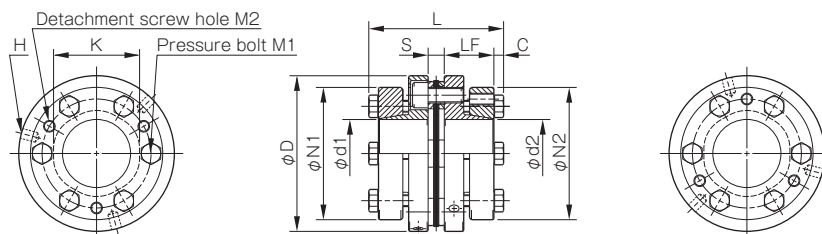

Model	d1 [mm]	d2 [mm]	D [mm]	L [mm]	N1 · N2 [mm]	LF [mm]	S [mm]	C [mm]	K [mm]	H [mm]	M 1 Qty - Nominal dia.	M1 Tightening torque [N · m]	M 2 Qty - Nominal dia.
SFF-070SS-□K-□K-100N	18 · 19	18 · 19	68	62.9	53	23.5	5.9	5	38	3-5.1	6-M6	10	3-M6
	20 · 22 · 24 · 25	20 · 22 · 24 · 25			58								
	28 · 30	28 · 30			63								
	32 · 35	32 · 35			68								
SFF-080SS-□K-□K-150N	22 · 24 · 25	22 · 24 · 25	78	69.3	58	25.5	8.3	5	37	4-5.1	4-M6	10	2-M6
	28 · 30	28 · 30			63								
	32 · 35	32 · 35			68								
	—	38			73								
SFF-080SS-□K-□K-200N	22 · 24 · 25	22 · 24 · 25	78	68.7	58	25.5	7.7	5	42	3-5.1	6-M6	10	3-M6
	28 · 30	28 · 30			63								
	32 · 35	32 · 35			68								
	38	38			73								
SFF-090SS-□K-□K-300N	28 · 30	28 · 30	88	69.3	63	25.5	8.3	5	50	3-6.8	6-M6	10	3-M6
	32 · 35	32 · 35			68								
	38 · 40 · 42	38 · 40 · 42			73								
	45	45			78								
SFF-100SS-□K-□K-450N	32 · 35	32 · 35	98	75.2	68	27.5	10.2	5	56	3-6.8	6-M6	10	3-M6
	38 · 40 · 42	38 · 40 · 42			73								
	45	45			78								
	48 · 50	48 · 50			83								
SFF-120SS-□K-□K-600N	35	35	118	75.2	68	27.5	10.2	5	68	3-6.8	6-M6	10	3-M6
	38 · 40 · 42	38 · 40 · 42			73								
	45	45			78								
	48 · 50 · 52	48 · 50 · 52			83								
	55	55			88								
	60 · 62 · 65	60 · 62 · 65			98								
—	70	108											
SFF-140SS-□K-□K-800N	35 · 38	35 · 38	138	94.6	83	36.5	10.6	5.5	78	3-8.6	6-M8	24	3-M8
	40 · 42 · 45	40 · 42 · 45			88								
	—	48 · 50 · 52			98								
	—	55 · 60			108								
	—	62 · 65 · 70			118								
SFF-140SS-□K-□K-1000N	—	75 · 80	138	94.6	128	36.5	10.6	5.5	78	3-8.6	6-M8	24	3-M8
	48 · 50 · 52	48 · 50 · 52			98								
	55 · 60	55 · 60			108								
	62 · 65 · 70	62 · 65 · 70			118								
75	75 · 80	128											

\* The nominal diameters of the pressure bolt M1 and detachment screw hole M2 are equal to the quantity minus the nominal diameter of the screw threads. The quantities of H, M1 and M2 are the same as the quantity for a hub on one side.

## COUPLINGS

ETP BUSHINGS

ELECTROMAGNETIC  
CLUTCHES & BRAKES

SPEED CHANGERS  
& REDUCERS

INVERTERS

LINEAR SHAFT DRIVES

TORQUE LIMITERS

ROSTA

### SERIES

Metal Disc  
Couplings  
**SERVOFLEX**

High-rigidity  
Couplings  
**SERVORIGID**

Metal Slit  
Couplings  
**HELI-CAL**

Metal Coil Spring  
Couplings  
**BAUMANNFLEX**

Pin Bushing  
Couplings  
**PARAFLEX**

Link Couplings  
**SCHMIDT**

Dual Rubber  
Couplings  
**STEPFLEX**

Jaw Couplings  
**MIKI PULLEY  
STARFLEX**

Jaw Couplings  
**SPRFLEX**

Plastic Bellows  
Couplings  
**BELLOWFLEX**

Rubber and Plastic  
Couplings  
**CENTAFLEX**

### MODELS

SFC

SFS

SFF

SFM

SFH

## Standard Bore Diameter

Model	Nominal diameter	Standard bore diameter d1 • d2 [mm]																							
		18	19	20	22	24	25	28	30	32	35	38	40	42	45	48	50	52	55	60	62	65	70	75	80
SFF-070SS-□K-□K-100N	d1	●	●	●	●	●	●	●	●	●	●														
	d2	●	●	●	●	●	●	●	●	●	●														
SFF-080SS-□K-□K-150N	d1				●	●	●	●	●	●	●														
	d2				●	●	●	●	●	●	●	●													
SFF-080SS-□K-□K-200N	d1				●	●	●	●	●	●	●	●													
	d2				●	●	●	●	●	●	●	●	●												
SFF-090SS-□K-□K-300N	d1						●	●	●	●	●	●	●	●	●										
	d2						●	●	●	●	●	●	●	●	●	●									
SFF-100SS-□K-□K-450N	d1								●	●	●	●	●	●	●	●	●								
	d2								●	●	●	●	●	●	●	●	●	●							
SFF-120SS-□K-□K-600N	d1									●	●	●	●	●	●	●	●	●	●	●	●	●	●	●	●
	d2									●	●	●	●	●	●	●	●	●	●	●	●	●	●	●	●
SFF-140SS-□K-□K-800N	d1										●	●	●	●	●	●	●	●	●	●	●	●	●	●	
	d2										●	●	●	●	●	●	●	●	●	●	●	●	●	●	
SFF-140SS-□K-□K-1000N	d1														●	●	●	●	●	●	●	●	●	●	
	d2														●	●	●	●	●	●	●	●	●	●	

### How to Place an Order

### SFF-080SS-25KK-30KK-200N

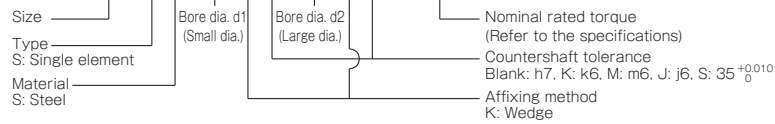

# SFF DS Types Double Element/Clamping

## Specifications

Model	Rated torque [N·m]	Misalignment			Max. rotation speed [min <sup>-1</sup> ]	Torsional stiffness [N·m/rad]	Axial stiffness [N/mm]	Moment of inertia [kg·m <sup>2</sup> ]	Mass [kg]
		Parallel [mm]	Angular [°]	Axial [mm]					
SFF-040DS-□B-□B-8N	8	0.10	1(On one side)	± 0.4	14000	7500	87	0.04 × 10 <sup>-3</sup>	0.22
SFF-040DS-□B-□B-12N	12	0.10	1(On one side)	± 0.4	14000	7500	87	0.04 × 10 <sup>-3</sup>	0.22
SFF-050DS-□B-□B-25N	25	0.20	1(On one side)	± 0.6	14000	16000	72.5	0.13 × 10 <sup>-3</sup>	0.46
SFF-060DS-□B-□B-60N	60	0.20	1(On one side)	± 0.6	14000	52000	199.5	0.28 × 10 <sup>-3</sup>	0.64
SFF-060DS-□B-□B-80N	80	0.20	1(On one side)	± 0.6	14000	52000	199.5	0.29 × 10 <sup>-3</sup>	0.61
SFF-070DS-□B-□B-90N	90	0.25	1(On one side)	± 1.0	14000	120000	242	0.53 × 10 <sup>-3</sup>	0.90
SFF-070DS-□B-□B-100N	100	0.25	1(On one side)	± 1.0	14000	120000	242	0.55 × 10 <sup>-3</sup>	0.85
SFF-080DS-□B-□B-150N	150	0.32	1(On one side)	± 1.0	13000	60000	48	1.10 × 10 <sup>-3</sup>	1.37
SFF-080DS-□B-□B-200N	200	0.31	1(On one side)	± 1.0	13000	155000	273	1.50 × 10 <sup>-3</sup>	1.72
SFF-090DS-□B-□B-250N	250	0.32	1(On one side)	± 1.2	12000	260000	160.5	2.03 × 10 <sup>-3</sup>	2.02
SFF-090DS-□B-□B-300N	300	0.32	1(On one side)	± 1.2	12000	260000	160.5	2.10 × 10 <sup>-3</sup>	1.92
SFF-100DS-□B-□B-450N	450	0.38	1(On one side)	± 1.3	10000	370000	270	4.18 × 10 <sup>-3</sup>	3.12
SFF-120DS-□B-□B-600N	600	0.38	1(On one side)	± 1.6	9000	485000	180	8.87 × 10 <sup>-3</sup>	4.60

\* Max. rotation speed does not take into account dynamic balance.  
 \* Torsional stiffness values given are measured values for the element alone.  
 \* The moment of inertia and mass are measured for the maximum bore diameter.

## Dimensions

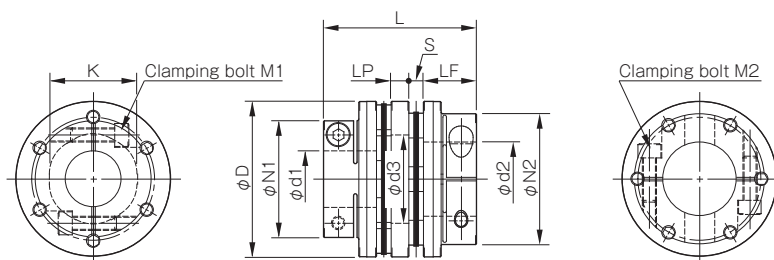

Model	d1 [mm]	d2 [mm]	D [mm]	L [mm]	N1 · N2 [mm]	LF [mm]	LP [mm]	S [mm]	d3 [mm]	K [mm]	M1 · M2 Qty - Nominal dia.	M1 · M2 Tightening torque [N · m]
SFF-040DS-□B-□B-8N	8 · 9 · 9.525	8 · 9 · 9.525 · 10 · 11 · 12 · 14 · 15 · 16	38	48.8	33	17.5	6	3.9	17	17	2-M4	3.4
SFF-040DS-□B-□B-12N	10 · 11 · 12 · 14 · 15 · 16	10 · 11 · 12 · 14 · 15 · 16	38	48.8	33	17.5	6	3.9	17	17	2-M4	3.4
SFF-050DS-□B-□B-25N	10 · 11 · 12 · 14 · 15 · 16 · 17 · 18 · 19	10 · 11 · 12 · 14 · 15 · 16 · 17 · 18 · 19	48	60.8	42	21.5	7	5.4	20	20	2-M5	7
SFF-060DS-□B-□B-60N	12 · 14 · 15 · 16 · 17 · 18 · 19	12 · 14 · 15 · 16 · 17 · 18 · 19 · 20 · 22	58	65.8	44	24	7	5.4	31	32	2-M6	14
	—	24 · 25 · 28			48						2-M5	7
	—	30			52						2-M6	14
SFF-060DS-□B-□B-80N	20 · 22	20 · 22	58	65.8	44	24	7	5.4	31	32	2-M6	14
	24 · 25 · 28	24 · 25 · 28			48						2-M5	7
	30	30			52						2-M5	7
SFF-070DS-□B-□B-90N	18 · 19	18 · 19 · 20 · 22 · 24 · 25	68	69.8	47	25	8	5.9	37	38	2-M6	14
	—	28 · 30 · 32 · 35			56						2-M6	14
SFF-070DS-□B-□B-100N	20 · 22 · 24 · 25	20 · 22 · 24 · 25	68	69.8	47	25	8	5.9	37	38	2-M6	14
	28 · 30 · 32 · 35	28 · 30 · 32 · 35			56						2-M6	14
SFF-080DS-□B-□B-150N	22 · 24 · 25	22 · 24 · 25	78	86.6	53	30	10	8.3	40	37	2-M8	34
	28 · 30 · 32 · 35	28 · 30 · 32 · 35			56						2-M6	14
	22 · 24 · 25	22 · 24 · 25			53						2-M8	34
SFF-080DS-□B-□B-200N	28 · 30 · 32 · 35	28 · 30 · 32 · 35	78	85.4	70	30	10	7.7	40	42	2-M8	34
	38	38			74						2-M8	34
SFF-090DS-□B-□B-250N	25 · 28	25 · 28 · 30 · 32	88	86.6	66	30	10	8.3	50	50	2-M8	34
	—	35 · 38 · 40 · 42			74						2-M8	34
SFF-090DS-□B-□B-300N	30 · 32	30 · 32	88	86.6	66	30	10	8.3	50	50	2-M8	34
	35 · 38 · 40 · 42	35 · 38 · 40 · 42			74						2-M8	34
SFF-100DS-□B-□B-450N	32 · 35 · 38 · 40 · 42 · 45 · 48	32 · 35 · 38 · 40 · 42 · 45 · 48	98	112.4	84	40	12	10.2	52	56	2-M10	68
SFF-120DS-□B-□B-600N	32 · 35 · 38 · 40 · 42 · 45	32 · 35 · 38 · 40 · 42 · 45	118	112.4	84	40	12	10.2	72	68	2-M10	68
	48 · 50 · 55	48 · 50 · 55			100						2-M10	68

\* Nominal diameter of clamping bolt M1/M2 is given as number of bolts - nominal diameter, and the number is the number for one hub.

## COUPLINGS

ETP BUSHINGS

ELECTROMAGNETIC CLUTCHES & BRAKES

SPEED CHANGERS & REDUCERS

INVERTERS

LINEAR SHAFT DRIVES

TORQUE LIMITERS

ROSTA

## SERIES

Metal Couplings	Metal Disc Couplings <b>SERVOFLEX</b>	
	High-rigidity Couplings <b>SERVORIGID</b>	
	Metal Slit Couplings <b>HELI-CAL</b>	
	Metal Coil Spring Couplings <b>BAUMANNFLEX</b>	
	Pin Bushing Couplings <b>PARAFLEX</b>	
	Link Couplings <b>SCHMIDT</b>	
	Rubber and Plastic Couplings	Dual Rubber Couplings <b>STEPFLEX</b>
		Jaw Couplings <b>MIKI PULLEY STARFLEX</b>
		Jaw Couplings <b>SPRFLEX</b>
		Plastic Bellows Couplings <b>BELLOWFLEX</b>
Rubber and Plastic Couplings <b>CENTAFLEX</b>		

## Standard Bore Diameter

Model	Nominal diameter	Standard bore diameter d1 · d2 [mm]																										
		8	9	9.525	10	11	12	14	15	16	17	18	19	20	22	24	25	28	30	32	35	38	40	42	45	48	50	55
SFF-040DS-□ B-□ B-8N	d1	●	●	●																								
	d2	●	●	●	●	●	●	●	●	●																		
SFF-040DS-□ B-□ B-12N	d1				●	●	●	●	●	●																		
	d2				●	●	●	●	●	●	●																	
SFF-050DS-□ B-□ B-25N	d1				●	●	●	●	●	●	●	●																
	d2				●	●	●	●	●	●	●	●	●															
SFF-060DS-□ B-□ B-60N	d1								●	●	●	●	●	●														
	d2								●	●	●	●	●	●	●													
SFF-060DS-□ B-□ B-80N	d1													●	●	●	●	●										
	d2													●	●	●	●	●	●									
SFF-070DS-□ B-□ B-90N	d1																●	●										
	d2																●	●	●	●	●	●						
SFF-070DS-□ B-□ B-100N	d1																											
	d2																											
SFF-080DS-□ B-□ B-150N	d1																											
	d2																											
SFF-080DS-□ B-□ B-200N	d1																											
	d2																											
SFF-090DS-□ B-□ B-250N	d1																											
	d2																											
SFF-090DS-□ B-□ B-300N	d1																											
	d2																											
SFF-100DS-□ B-□ B-450N	d1																											
	d2																											
SFF-120DS-□ B-□ B-600N	d1																											
	d2																											

\* The bore diameters marked with ● are supported as standard bore diameter.

## Tapered shaft supported Option

Model	Rated torque [N · m]	Moment of inertia [kg · m <sup>2</sup> ]	Mass [kg]
SFF-040DS-□ B-11CN-8N	8	0.04 × 10 <sup>-3</sup>	0.25
SFF-040DS-□ B-11CN-12N	12	0.04 × 10 <sup>-3</sup>	0.23
SFF-050DS-□ B-14CN-25N	25	0.12 × 10 <sup>-3</sup>	0.45
SFF-050DS-□ B-16CN-25N	25	0.13 × 10 <sup>-3</sup>	0.49
SFF-060DS-□ B-16CN-60N	60	0.24 × 10 <sup>-3</sup>	0.67
SFF-060DS-□ B-16CN-80N	80	0.26 × 10 <sup>-3</sup>	0.64

\* The moment of inertia and mass are measured for the maximum bore diameter.

\* For other "Specifications", see "Specifications" for Double Element/Clamping.

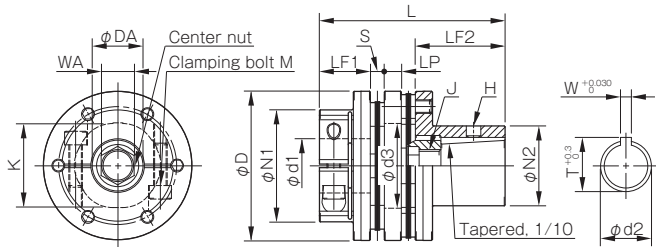

Model	d1 [mm]	d2 [mm]	W [mm]	T [mm]	D [mm]	L [mm]	N1 [mm]	N2 [mm]	LF1 [mm]	LF2 [mm]	LP [mm]	S [mm]	d3 [mm]	K [mm]	H [mm]	M Qty - Nominal dia.	M Tightening torque [N · m]	DA [mm]	WA [mm]	J Nominal × pitch	J Tightening torque [N · m]	
SFF-040DS-□ B-11CN-8N	8 ~ 9.525	11	4	12.2	38	56.3	33	22	17.5	25	6	3.9	17	17	5.1	2-M4	3.4	12	6	M6 × 1.0	10	
SFF-040DS-□ B-11CN-12N	10 ~ 16	11	4	12.2	38	56.3	33	22	17.5	25	6	3.9	17	17	5.1	2-M4	3.4	12	6	M6 × 1.0	10	
SFF-050DS-□ B-14CN-25N	10 ~ 19	14	4	15.1	48	69.3	42	27.5	21.5	30	7	5.4	20	20	5.1	2-M5	7	15	8	M8 × 1.0	20	
SFF-050DS-□ B-16CN-25N	10 ~ 19	16	5	17.3	48	80.3	42	29.5	21.5	41	7	5.4	20	20	6.8	2-M5	7	16	10	M10 × 1.25	30	
SFF-060DS-□ B-16CN-60N	12 ~ 19	16	5	17.3	58	82.8	44	29.5	24	41	7	5.4	31	32	6.8	2-M6	14	16	10	M10 × 1.25	30	
	20 ~ 22						44									2-M6	14					
	24 ~ 28	16	5	17.3	58	82.8	48	29.5	24	41	7	5.4	31	32	6.8	2-M5	7	16	10	M10 × 1.25	30	
	30						52															

## How to Place an Order

### SFF-080DS-25BK-30BK-200N

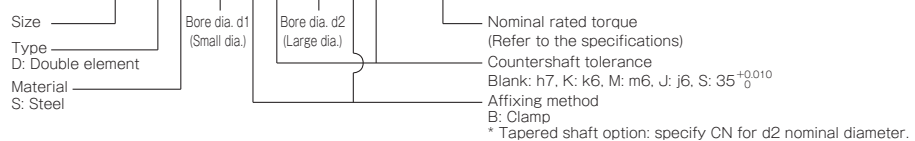

# SFF DS Types Double Element/Wedge Coupling

## Specifications

Model	Rated torque [N·m]	Misalignment			Max. rotation speed [min <sup>-1</sup> ]	Torsional stiffness [N·m/rad]	Axial stiffness [N/mm]	Moment of inertia [kg·m <sup>2</sup> ]	Mass [kg]
		Parallel [mm]	Angular [°]	Axial [mm]					
SFF-070DS-□K-□K-100N	100	0.25	1(On one side)	± 1.0	14000	120000	242	0.80 × 10 <sup>-3</sup>	1.10
SFF-080DS-□K-□K-150N	150	0.32	1(On one side)	± 1.0	13000	60000	48	1.36 × 10 <sup>-3</sup>	1.56
SFF-080DS-□K-□K-200N	200	0.31	1(On one side)	± 1.0	13000	155000	273	1.42 × 10 <sup>-3</sup>	1.60
SFF-090DS-□K-□K-300N	300	0.32	1(On one side)	± 1.2	12000	260000	160.5	2.24 × 10 <sup>-3</sup>	1.87
SFF-100DS-□K-□K-450N	450	0.38	1(On one side)	± 1.3	10000	370000	270	3.51 × 10 <sup>-3</sup>	2.49
SFF-120DS-□K-□K-600N	600	0.38	1(On one side)	± 1.6	9000	485000	180	7.17 × 10 <sup>-3</sup>	3.29
SFF-140DS-□K-□K-800N	800	0.44	1(On one side)	± 2.0	8000	700000	180	14.68 × 10 <sup>-3</sup>	6.05
SFF-140DS-□K-□K-1000N	1000	0.44	1(On one side)	± 2.0	8000	700000	180	19.11 × 10 <sup>-3</sup>	6.39

\* Max. rotation speed does not take into account dynamic balance.  
 \* Torsional stiffness values given are measured values for the element alone.  
 \* The moment of inertia and mass are measured for the maximum bore diameter.

## Dimensions

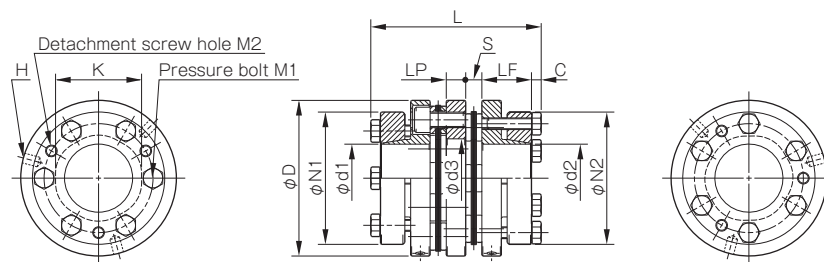

Model	d1 [mm]	d2 [mm]	D [mm]	L [mm]	N1 · N2 [mm]	LF [mm]	LP [mm]	S [mm]	C [mm]	d3 [mm]	K [mm]	H [mm]	M1 Qty - Nominal dia.	M1 Tightening torque [N · m]	M2 Qty - Nominal dia.
SFF-070DS-□K-□K-100N	18 · 19	18 · 19	68	76.8	53	23.5	8	5.9	5	37	38	3-5.1	6-M6	10	3-M6
	20 · 22 · 24 · 25	20 · 22 · 24 · 25			58										
	28 · 30	28 · 30			63										
	32 · 35	32 · 35			68										
SFF-080DS-□K-□K-150N	22 · 24 · 25	22 · 24 · 25	78	87.6	58	25.5	10	8.3	5	40	37	4-5.1	4-M6	10	2-M6
	28 · 30	28 · 30			63										
	32 · 35	32 · 35			68										
	—	38			73										
SFF-080DS-□K-□K-200N	22 · 24 · 25	22 · 24 · 25	78	86.4	58	25.5	10	7.7	5	40	42	3-5.1	6-M6	10	3-M6
	28 · 30	28 · 30			63										
	32 · 35	32 · 35			68										
SFF-090DS-□K-□K-300N	28 · 30	28 · 30	88	87.6	63	25.5	10	8.3	5	50	50	3-6.8	6-M6	10	3-M6
	32 · 35	32 · 35			68										
	38 · 40 · 42	38 · 40 · 42			73										
	45	45			78										
SFF-100DS-□K-□K-450N	48	48	98	97.4	83	27.5	12	10.2	5	52	56	3-6.8	6-M6	10	3-M6
	38 · 40 · 42	38 · 40 · 42			73										
	45	45			78										
SFF-120DS-□K-□K-600N	48 · 50	48 · 50	118	97.4	83	27.5	12	10.2	5	72	68	3-6.8	6-M6	10	3-M6
	35	35			68										
	38 · 40 · 42	38 · 40 · 42			73										
	45	45			78										
	48 · 50 · 52	48 · 50 · 52			83										
	55	55			88										
SFF-140DS-□K-□K-800N	60 · 62 · 65	60 · 62 · 65	138	120.2	98	36.5	15	10.6	5.5	80	78	3-8.6	6-M8	24	3-M8
	—	70			108										
	35 · 38	35 · 38			83										
	40 · 42 · 45	40 · 42 · 45			88										
SFF-140DS-□K-□K-1000N	—	48 · 50 · 52	138	120.2	98	36.5	15	10.6	5.5	80	78	3-8.6	6-M8	24	3-M8
	—	55 · 60			108										
	—	62 · 65 · 70			118										
	—	75 · 80			128										
SFF-140DS-□K-□K-1000N	48 · 50 · 52	48 · 50 · 52	138	120.2	98	36.5	15	10.6	5.5	80	78	3-8.6	6-M8	24	3-M8
	55 · 60	55 · 60			108										
	62 · 65 · 70	62 · 65 · 70			118										
	75	75 · 80			128										

\* The nominal diameters of the pressure bolt M1 and detachment screw hole M2 are equal to the quantity minus the nominal diameter of the screw threads. The quantities of H, M1 and M2 are the same as the quantity for a hub on one side.

## COUPLINGS

ETP BUSHINGS

ELECTROMAGNETIC  
CLUTCHES & BRAKES

SPEED CHANGERS  
& REDUCERS

INVERTERS

LINEAR SHAFT DRIVES

TORQUE LIMITERS

ROSTA

### SERIES

Metal Disc  
Couplings  
**SERVOFLEX**

High-rigidity  
Couplings  
**SERVORIGID**

Metal Slit  
Couplings  
**HELI-CAL**

Metal Coil Spring  
Couplings  
**BAUMANNFLEX**

Pin Bushing  
Couplings  
**PARAFLEX**

Link Couplings  
**SCHMIDT**

Dual Rubber  
Couplings  
**STEPFLEX**

Jaw Couplings  
**MIKI PULLEY  
STARFLEX**

Jaw Couplings  
**SPRFLEX**

Plastic Bellows  
Couplings  
**BELLOWFLEX**

Rubber and Plastic  
Couplings  
**CENTAFLEX**

### MODELS

SFC

SFS

SFF

SFM

SFH

## Standard Bore Diameter

Model	Nominal diameter	Standard bore diameter d1 · d2 [mm]																							
		18	19	20	22	24	25	28	30	32	35	38	40	42	45	48	50	52	55	60	62	65	70	75	80
SFF-070DS-□K-□K-100N	d1	●	●	●	●	●	●	●	●	●	●														
	d2	●	●	●	●	●	●	●	●	●	●														
SFF-080DS-□K-□K-150N	d1				●	●	●	●	●	●	●														
	d2				●	●	●	●	●	●	●	●													
SFF-080DS-□K-□K-200N	d1				●	●	●	●	●	●	●	●													
	d2				●	●	●	●	●	●	●	●	●												
SFF-090DS-□K-□K-300N	d1						●	●	●	●	●	●	●	●	●	●									
	d2						●	●	●	●	●	●	●	●	●	●	●								
SFF-100DS-□K-□K-450N	d1								●	●	●	●	●	●	●	●	●	●							
	d2								●	●	●	●	●	●	●	●	●	●	●						
SFF-120DS-□K-□K-600N	d1									●	●	●	●	●	●	●	●	●	●	●	●	●	●	●	●
	d2									●	●	●	●	●	●	●	●	●	●	●	●	●	●	●	●
SFF-140DS-□K-□K-800N	d1										●	●	●	●	●	●	●	●	●	●	●	●	●	●	●
	d2										●	●	●	●	●	●	●	●	●	●	●	●	●	●	●
SFF-140DS-□K-□K-1000N	d1														●	●	●	●	●	●	●	●	●	●	●
	d2														●	●	●	●	●	●	●	●	●	●	●

### How to Place an Order

### SFF-080DS-25KK-30KK-200N

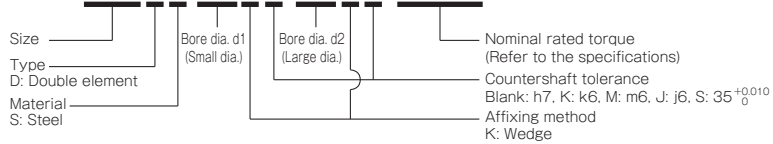

# SFF Models

## Items Checked for Design Purposes

### Special Items to Take Note of

You should note the following to prevent any problems.

- (1) Always be careful of parallel, angular, and axial misalignment.
- (2) Always tighten bolts with the specified torque.

### Precautions for Handling

Couplings are assembled at high accuracy using a special mounting jig to ensure accurate concentricity of left and right internal diameters. Take extra precautions when handling couplings, should strong shocks be given on couplings, it may affect mounting accuracy and cause the parts to break during use.

- (1) Couplings are designed for use within an operating temperature range of -30°C to 120°C. Although the couplings are designed to be waterproof and oilproof, do not subject them to excessive amounts of water and oil as it may cause part deterioration.
- (2) Handle the element with care as it is made of a thin stainless steel metal disc, also making sure to be careful so as not to injure yourself.
- (3) Do not tighten up clamping bolts or pressure bolts until after inserting the mounting shaft.

### Mounting (Clamping)

- (1) Check that coupling clamping bolts have been loosened and remove any rust, dust, oil residue, etc. from the inner diameter surfaces of the shaft and couplings. In particular, never allow oil or grease containing antifriction or other agent (molybdenum-, silicon-, or fluorine-based), which would dramatically affect the friction coefficient, to contact the surface.
- (2) Be careful when inserting the couplings onto the shaft so as not to apply excessive force of compression or tensile force to the element.
- (3) Ensure that the length of the coupling inserted onto the motor shaft touches the shaft for the entire length of the clamping hub of the coupling (LF dimension), as shown in the diagram below, and position it so that it does not interfere with the elements, spacers or the other shaft. Then temporarily tighten the two clamping bolts, tightening them alternately until the coupling cannot be manually rotated.

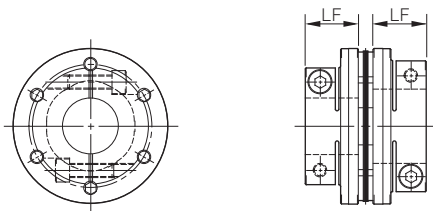

Model (Clamping)	LF dimension [mm]
SFF-040	17.5
SFF-050	21.5
SFF-060	24
SFF-070	25
SFF-080	30
SFF-090	30
SFF-100	40
SFF-120	40

- (4) Hold a dial gauge against the outer diameter of the clamping hub on the motor shaft side (the surface processed simultaneously with the inner diameter), and then tighten the two clamping bolts while turning the motor shaft by hand and adjusting the difference in the runout values at A and B in the figure below is 0.02 mm or less (and as close to 0 as possible).

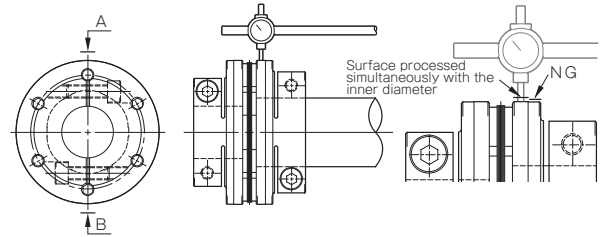

- (5) Alternately fasten the two clamping bolts as you adjust them, and finish by tightening both bolts to the appropriate tightening torque of the following table, using a calibrated torque wrench. Since it is fastened by two clamping bolts, tightening one bolt before the other will place more than the prescribed axial force on the bolt tightened first when the other bolt is tightened. Be sure to tighten them alternately, a little at a time.

Clamping bolt nominal diameter	Tightening torque [N·m]
M4	3.4
M5	7
M6	14
M8	34
M10	68

- (6) Mount the motor, to which the coupling has already been mounted, on the body of the machinery. At that time, adjust the motor mounting position (centering location) while inserting the coupling onto the driven shaft (a feed screw or the like), being alert to undue forces on the element such as compression or pulling.
- (7) Make the length of the driven shaft (feed screw or the like) inserted into the coupling connect to the shaft for the length of the LF dimension (described above), alternately tighten the two clamping bolts, and provisionally tighten enough that the coupling cannot be manually rotated.
- (8) In addition, keep the dimension between clamping hub faces (the S dimension in the diagram) to within the allowable misalignment of the axial displacement with respect to a reference value. Note that the tolerance values were calculated based on the assumption that both the level of parallel misalignment and angular deflection are zero. Adjust to keep this value as low as possible.

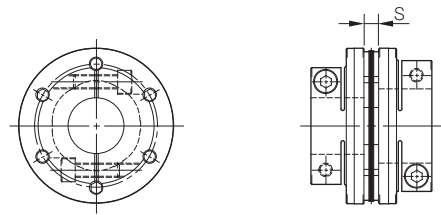

Model (Clamping)	S dimension [mm]
SFF-040	3.9
SFF-050	5.4
SFF-060	5.4
SFF-070	5.9
SFF-080 (-150N)	8.3
SFF-080 (-200N)	7.7
SFF-090	8.3
SFF-100	10.2
SFF-120	10.2

- (9) Adjust runout using the same procedure as for the motor shaft side, and then finish by tightening the clamping bolts to the appropriate tightening torque.
- (10) To protect against initial loosening of the clamping bolt, we recommend operating for a set period of time and then retightening to the appropriate tightening torque.

## Mounting (Wedge Coupling)

- (1) Check that coupling pressure bolts have been loosened and remove any rust, dust, oil residue, etc. from the inner diameter surfaces of the shaft and couplings. In particular, never allow oil or grease containing antifricition or other agent (molybdenum-, silicon-, or fluorine-based), which would dramatically affect the friction coefficient, to contact the surface.
- (2) Be careful when inserting the couplings into the shaft so as not to apply excessive force of compression or tensile force to the element.
- (3) Insert each coupling far enough onto the motor shaft that it touches the shaft along the entire length of the coupling flange (LF dimension), as shown in the diagram below. Position it so that it does not interfere with the elements, spacers or the other shaft and then hold it in place.

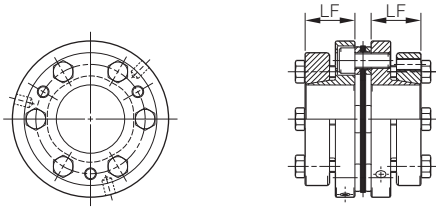

Model (Wedge coupling)	LF dimension [mm]
SFF-070	23.5
SFF-080	25.5
SFF-090	25.5
SFF-100	27.5
SFF-120	27.5
SFF-140	36.5

- (4) Using the drive pin hole, lightly tighten the pressure bolt on the diagonal.

- (5) Touch the dial gauge to the flange end face or outer diameter on the motor shaft side. Then, while gently rotating the motor shaft manually, adjust the flange periphery and end face by hammering until the runout is as close to zero as possible.

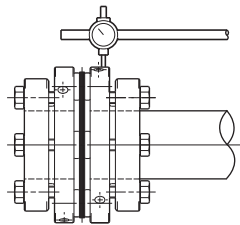

- (6) Sequentially fasten the pressure bolts while doing hammering adjustments, and then use a calibrated torque wrench to tighten all the pressure bolts to the appropriate tightening torques below. See the following figure for the tightening procedure for the pressure bolts. Try to tighten them evenly.

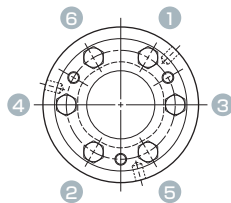

Pressure bolt nominal diameter	Tightening torque [N·m]
M6	10
M8	24

- (7) Tighten the motor shaft's pressure bolts at the nominal torque and check that the runout value is low.
- (8) Mount the motor, to which the coupling has already been mounted, on the body of the machinery. At that time, adjust the motor mounting position (centering location) while inserting the coupling onto the driven shaft (a feed screw or the like), taking care to not deform the disc. Also insert each coupling far enough onto the paired shaft that it touches the shaft along the entire length of the coupling flange (LF dimension) and then hold it in that position.

- (9) Keep the width of the dimension between flange faces (S dimension in the diagram) within the allowable error range for axial misalignment with respect to the reference value. Note that the tolerance values were calculated based on the assumption that both the level of parallel misalignment and angular deflection are zero. Adjust to keep this value as low as possible.

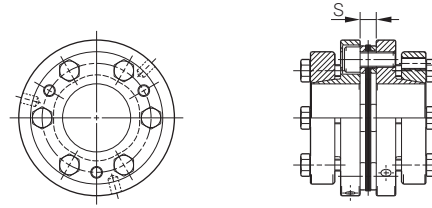

Model	S dimension [mm]
SFF-070	5.9
SFF-080 (-150N)	8.3
SFF-080 (-200N)	7.7
SFF-090	8.3
SFF-100	10.2
SFF-120	10.2
SFF-140	10.6

- (10) Sequentially tighten the pressure bolts on the driven shaft (a feed screw or the like) side using the same procedure as for the motor shaft side pressure bolts, and then tighten to the appropriate tightening torque.
- (11) To protect against initial loosening of the pressure bolt, we recommend operating for a set period of time and then retightening to the appropriate tightening torque.

### COUPLINGS

ETP BUSHINGS

ELECTROMAGNETIC CLUTCHES & BRAKES

SPEED CHANGERS & REDUCERS

INVERTERS

LINEAR SHAFT DRIVES

TORQUE LIMITERS

ROSTA

### SERIES

Metal Couplings	Metal Disc Couplings <b>SERVOFLEX</b>
	High-rigidity Couplings <b>SERVORIGID</b>
	Metal Slit Couplings <b>HELI-CAL</b>
	Metal Coil Spring Couplings <b>BAUMANNFLEX</b>
Rubber and Plastic Couplings	Pin Bushing Couplings <b>PARAFLEX</b>
	Link Couplings <b>SCHMIDT</b>
	Dual Rubber Couplings <b>STEPFLEX</b>
	Jaw Couplings <b>MIKI PULLEY STARFLEX</b>
	Jaw Couplings <b>SPRFLEX</b>
	Plastic Bellows Couplings <b>BELLOWFLEX</b>
	Rubber and Plastic Couplings <b>CENTAFLEX</b>

### MODELS

SFC

SFS

SFF

SFM

SFH



# SFF Models

## Items Checked for Design Purposes

### I Removal

- (1) Check to confirm that there is no torque or axial load being applied to the coupling. There may be cases where a torque is applied to the coupling, particularly when the safety brake is being used. Make sure to verify that this is not occurring before removing parts.
- (2) Loosen all the clamping bolts or pressure bolts (loosen pressure bolts until the gap between bearing seat and sleeve is about 2mm).
- (3) For clamping type, release the fastening to the shaft by sufficiently loosening all clamping bolts. Note that grease has been applied to the clamping bolts, so do not remove them all the way.
- (4) In the case of a wedge coupling system that tightens a pressure bolt from the axial direction, the sleeve will be self-locking, so the coupling between flange and shaft cannot be released simply by loosening the pressure bolt. (Note that in some cases, a coupling can be released by loosening a pressure bolt.) For that reason, when designing devices, a space must be installed for inserting a detachment screw.

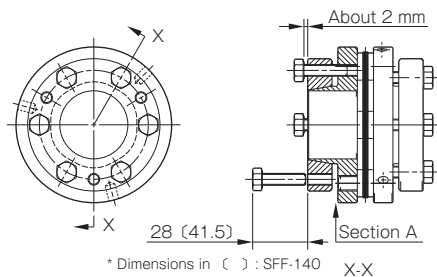

- (5) Pull out three of the pressure bolts (two 080, 150 N) loosened in step (2), insert them into the detachment screw holes on the sleeve, and tighten them in order, a little at a time. The coupling will be released.
- (6) If there is no space in the axial direction, insert the tip of a flathead screwdriver or the like into part A and lightly tap perpendicular to the shaft or use it as a lever to pry off the coupling. Use appropriate caution to not damage the coupling body or the pressure bolts.

### I Suitable Torque Screwdriver/Torque Wrench

#### ■ Clamping bolt

Nominal bolt diameter	Tightening torque [N · m]	Torque screwdriver/wrench	Hexagon bit/head	Coupling size
M4	3.4	CN500LTDK	SB 3mm	040
M5	7	N10LTDK	SB 4mm	050 · 060
M6	14	N25LCK	25HCK 5mm	060 · 070 · 080
M8	34	N50LCK	50HCK 6mm	080 · 090
M10	68	N100SPCK × 68N · m	100HCK 8mm	100 · 120

\* Torque screwdriver (wrench)/bit (head) models are those of Nakamura Mfg. Co., Ltd.

#### ■ Pressure bolt

Nominal bolt diameter	Tightening torque [N · m]	Torque wrench	Spanner head	Coupling size
M6	10	N12SPCK × 10N · m	25SCK 10mm	070 ~ 120
M8	24	N50SPCK × 24N · m	50SCK 13mm	140

\* Torque wrench/spanner head models are those of Nakamura Mfg. Co., Ltd.

### I Differences in Torsional Stiffness due to Element Shape

Elements used by SFF models may be either square or hexagonal. Since torque is transmitted by coupling the hubs to each other via the element, torsional stiffness is higher in couplings that use hexagonal elements transmitting torque with six bolts, at the expense of some flexibility. Choose your element shape accordingly.

Model (nominal rated torque)	Element shape
SFF-040	Square
SFF-050	Square
SFF-060	Hexagonal
SFF-070	Hexagonal
SFF-080 (-150N)	Square
SFF-080 (-200N)	Hexagonal
SFF-090	Hexagonal
SFF-100	Hexagonal
SFF-120	Hexagonal
SFF-140	Hexagonal

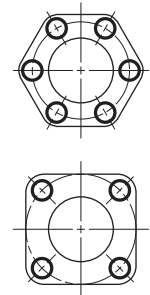

### I Center Nut for Tapered Shafts

The center nut designated for clamping-type sizes 040/050/060 is shipped pre-installed depending on the opposite coupling-end bore diameter. Check the table below.

Clamping hub type model	Center nut installation
SFF-040 □ - □ B-11CN-8N	All pre-installed
SFF-040 □ - □ B-11CN-12N	Installed where d1 < d12
SFF-050 □ - □ B-14CN-25N	Installed where d1 < d15
SFF-050 □ - □ B-16CN-25N	Installed where d1 < d16
SFF-060 □ - □ B-16CN-60N	Installed where d1 < d16
SFF-060 □ - □ B-16CN-80N	All bundled

### I Clamping and Wedge Coupling in Combination

For the range of common sizes between clamping and wedge coupling (070 - 120), a common element is used per each size allowing you to use them in combination. When specifying bore diameters in this instance, specify d1: clamping, d2: wedge coupling in that order, regardless of larger and smaller bore diameters.

### Example) SFF-080SS-30B-25K-200N



Rated torques after combination are given for the clamping side. See the table below.

d1 clamping (designation B)		d2 wedge coupling (designation K)		Rated torque after combination [N·m]
Model	Bore diameter range [mm]	Model	Bore diameter range [mm]	
SFF-070 (-90N)	18 · 19	SFF-070 (-100N)	18 ~ 35	90
SFF-070 (-100N)	20 ~ 35	SFF-070 (-100N)	18 ~ 35	100
SFF-080 (-150N)	22 ~ 35	SFF-080 (-150N)	22 ~ 38	150
SFF-080 (-200N)	22 ~ 38	SFF-080 (-200N)	22 ~ 38	200
SFF-090 (-250N)	25 · 28	SFF-090 (-300N)	28 ~ 48	250
SFF-090 (-300N)	30 ~ 42	SFF-090 (-300N)	28 ~ 48	300
SFF-100 (-450N)	32 ~ 48	SFF-100 (-450N)	32 ~ 50	450
SFF-120 (-600N)	32 ~ 55	SFF-120 (-600N)	35 ~ 70	600

## Points to Consider Regarding the Feed Screw System

Gain adjustment on the servo motor may cause the servo motor to oscillate. Oscillation in the servo motor during operation can cause problems particularly with the overall natural frequency and electrical control systems of the feed screw system.

In order for these issues to be resolved, the torsional stiffness for the coupling and feed screw section and the moment of inertia and other characteristics for the system overall will need to be adjusted and the torsional natural frequency for the mechanical system raised or the tuning function (filter function) for the electrical control system in the servo motor adjusted during the design stage.

## How to Find the Natural Frequency of a Feed Screw System

Select a coupling based on the maximum torque of the servo motor. Next, find the overall natural frequency,  $N_f$ , from the torsional stiffness of the coupling and feed screw,  $\kappa$ , the moment of inertia of driving side,  $J_1$ , and the moment of inertia of driven side,  $J_2$ , for the feed screw system shown below.

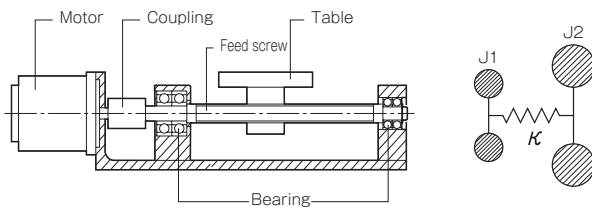

Natural frequency of overall feed screw system  $N_f$

$$N_f = \frac{1}{2\pi} \sqrt{\kappa \left( \frac{1}{J_1} + \frac{1}{J_2} \right)}$$

$N_f$ : Overall natural frequency of a feed screw system [Hz]

$\kappa$ : Torsional stiffness of the coupling and feed screw [N-m/rad]

$J_1$ : Moment of inertia of driving side [kg-m<sup>2</sup>]

$J_2$ : Moment of inertia of driven side [kg-m<sup>2</sup>]

Torsional spring constant of coupling and feed screw  $\kappa$

$$\frac{1}{\kappa} = \frac{1}{\kappa_c} + \frac{1}{\kappa_b}$$

$\kappa_c$ : Torsional spring constant of coupling [kg-m<sup>2</sup>]  
 $\kappa_b$ : Torsional spring constant of feed screw [kg-m<sup>2</sup>]

Driving moment of inertia  $J_1$

$$J_1 = J_m + \frac{J_c}{2}$$

$J_m$ : Moment of inertia of servomotor [kg-m<sup>2</sup>]  
 $J_c$ : Moment of inertia of coupling [kg-m<sup>2</sup>]

Driven moment of inertia  $J_2$

$$J_2 = J_b + J_t + \frac{J_c}{2}$$

$J_b$ : Moment of inertia of feedscrew [kg-m<sup>2</sup>]  
 $J_t$ : Moment of inertia of table [kg-m<sup>2</sup>]  
 $J_c$ : Moment of inertia of coupling [kg-m<sup>2</sup>]

Moment of inertia of table  $J_t$

$$J_t = \frac{M \times P^2}{4\pi^2}$$

$M$ : Mass of table [kg]  
 $P$ : Lead of feed screw [m]

Since it is easier for oscillation to occur when the gain margin with natural frequency is 10 dB or lower, it is necessary for the natural frequency to be set high with a therefore higher gain margin at the design stage, or to adjust the natural frequency using the servomotor's electric tuning function (filter function) so as to avoid oscillation.

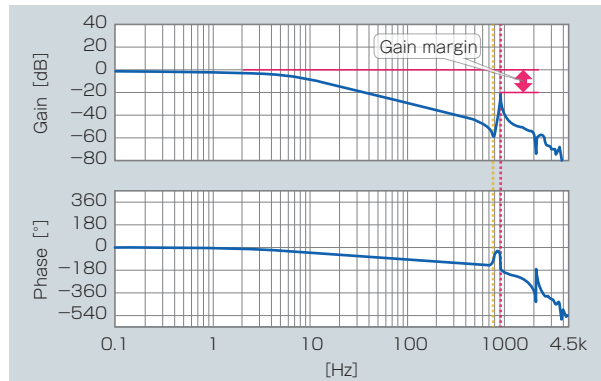

## Selection Procedures

(1) Find the torque,  $T_a$ , applied to the coupling using the output capacity,  $P$ , of the driver and the usage rotation speed,  $n$ .

$$T_a \text{ [N}\cdot\text{m]} = 9550 \times \frac{P \text{ [kW]}}{n \text{ [min}^{-1}\text{]}}$$

(2) Determine the factor  $K$  from the load properties, and find the corrected torque,  $T_d$ , applied to the coupling.

$$T_d \text{ [N}\cdot\text{m]} = T_a \text{ [N}\cdot\text{m]} \times K \text{ (Refer to the table below for values)}$$

Load properties	Constant	Vibrations: Small	Vibrations: Medium	Vibrations: Large
$K$	1.0	1.25	1.75	2.25

For servo motor drive, multiply the maximum torque,  $T_s$ , by the usage factor  $K = 1.2$  to  $1.5$ .

$$T_d \text{ [N}\cdot\text{m]} = T_s \text{ [N}\cdot\text{m]} \times (1.2 \sim 1.5)$$

(3) Set the size so that the rated coupling torque,  $T_n$ , is higher than the corrected torque,  $T_d$ .

$$T_n \text{ [N}\cdot\text{m]} \geq T_d \text{ [N}\cdot\text{m]}$$

(4) Check that the mount shaft is no larger than the maximum bore diameter of the coupling.

\* Contact Miki Pulley for assistance with any device experiencing extreme periodic vibrations.

### COUPLINGS

ETP BUSHINGS

ELECTROMAGNETIC CLUTCHES & BRAKES

SPEED CHANGERS & REDUCERS

INVERTERS

LINEAR SHAFT DRIVES

TORQUE LIMITERS

ROSTA

### SERIES

Metal Couplings	Metal Disc Couplings SERVOFLEX
	High-rigidity Couplings SERVORIGID
	Metal Slit Couplings HELI-CAL
	Metal Coil Spring Couplings BAUMANNFLEX
Pin Bushing Couplings	PARAFLEX
	Link Couplings SCHMIDT
Rubber and Plastic Couplings	Dual Rubber Couplings STEPFLEX
	Jaw Couplings MIKI PULLEY STARFLEX
	Jaw Couplings SPRFLEX
	Plastic Bellows Couplings BELLOWFLEX
	Rubber and Plastic Couplings CENTAFLEX

### MODELS

SFC

SFS

SFF

SFM

SFH

# SFM Types Clamping

## Specifications

Model	Rated torque [N·m]	Misalignment			Max. rotation speed [min <sup>-1</sup> ]	Torsional stiffness [N·m/rad]	Axial stiffness [N/mm]	Moment of inertia [kg·m <sup>2</sup> ]	Mass [kg]
		Parallel [mm]	Angular [°]	Axial [mm]					
SFM-060SS-□B-□B-60N	60	0.02	1	± 0.3	24000	104000	399	0.22 × 10 <sup>-3</sup>	0.52
SFM-060SS-□B-□B-80N	80	0.02	1	± 0.3	24000	104000	399	0.23 × 10 <sup>-3</sup>	0.49
SFM-070SS-□B-□B-90N	90	0.02	1	± 0.5	24000	240000	484	0.40 × 10 <sup>-3</sup>	0.72
SFM-070SS-□B-□B-100N	100	0.02	1	± 0.5	24000	240000	484	0.42 × 10 <sup>-3</sup>	0.67
SFM-080SS-□B-□B-150N	150	0.02	1	± 0.5	24000	120000	96	0.79 × 10 <sup>-3</sup>	1.04
SFM-080SS-□B-□B-200N	200	0.02	1	± 0.5	24000	310000	546	1.25 × 10 <sup>-3</sup>	1.40
SFM-090SS-□B-□B-250N	250	0.02	1	± 0.6	24000	520000	321	1.54 × 10 <sup>-3</sup>	1.62
SFM-090SS-□B-□B-300N	300	0.02	1	± 0.6	24000	520000	321	1.58 × 10 <sup>-3</sup>	1.53
SFM-100SS-□B-□B-450N	450	0.02	1	± 0.65	20000	740000	540	3.27 × 10 <sup>-3</sup>	2.53
SFM-120SS-□B-□B-600N	600	0.02	1	± 0.8	20000	970000	360	6.90 × 10 <sup>-3</sup>	3.78

\* Torsional stiffness values given are calculated for the element alone.

\* The moment of inertia and mass are measured for the maximum bore diameter.

## Dimensions

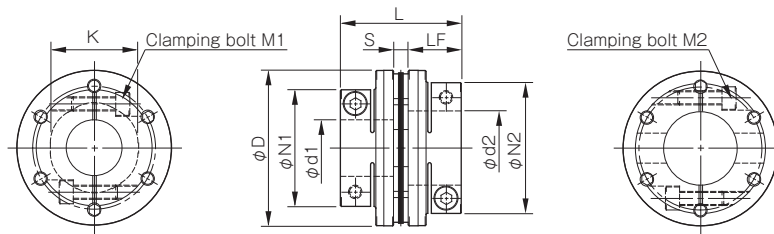

Model	d1 [mm]	d2 [mm]	D [mm]	L [mm]	N1 · N2 [mm]	LF [mm]	S [mm]	K [mm]	M1 · M2 Qty - Nominal dia.	M1 · M2 Tightening torque [N · m]
SFM-060SS-□B-□B-60N	12 · 14 · 15 · 16 · 17 · 18 · 19	12 · 14 · 15 · 16 · 17 · 18 · 19 · 20 · 22	58	53.4	44	24	5.4	32	2-M6	14
	—	24 · 25 · 28			48				2-M5	7
	—	30			52					
SFM-060SS-□B-□B-80N	20 · 22	20 · 22	58	53.4	44	24	5.4	32	2-M6	14
	24 · 25 · 28	24 · 25 · 28			48				2-M5	7
	30	30			52					
SFM-070SS-□B-□B-90N	18 · 19	18 · 19 · 20 · 22 · 24 · 25	68	55.9	47	25	5.9	38	2-M6	14
	—	28 · 30 · 32 · 35			56					
SFM-070SS-□B-□B-100N	20 · 22 · 24 · 25	20 · 22 · 24 · 25	68	55.9	47	25	5.9	38	2-M6	14
	28 · 30 · 32 · 35	28 · 30 · 32 · 35			56					
SFM-080SS-□B-□B-150N	22 · 24 · 25	22 · 24 · 25	78	68.3	53	30	8.3	37	2-M8	34
	28 · 30 · 32 · 35	28 · 30 · 32 · 35			56				2-M6	14
SFM-080SS-□B-□B-200N	22 · 24 · 25	22 · 24 · 25	78	67.7	53	30	7.7	42	2-M8	34
	28 · 30 · 32 · 35	28 · 30 · 32 · 35			70					
	38	38			74					
SFM-090SS-□B-□B-250N	25 · 28	25 · 28 · 30 · 32	88	68.3	66	30	8.3	50	2-M8	34
	—	35 · 38 · 40 · 42			74					
SFM-090SS-□B-□B-300N	30 · 32	30 · 32	88	68.3	66	30	8.3	50	2-M8	34
	35 · 38 · 40 · 42	35 · 38 · 40 · 42			74					
SFM-100SS-□B-□B-450N	32 · 35 · 38 · 40 · 42 · 45 · 48	32 · 35 · 38 · 40 · 42 · 45 · 48	98	90.2	84	40	10.2	56	2-M10	68
SFM-120SS-□B-□B-600N	32 · 35 · 38 · 40 · 42 · 45	32 · 35 · 38 · 40 · 42 · 45	118	90.2	84	40	10.2	68	2-M10	68
	48 · 50 · 55	48 · 50 · 55			100					

\* Nominal diameter of clamping bolt M1/M2 is given as number of bolts - nominal diameter, and the number is the number for one hub.

## COUPLINGS

ETP BUSHINGS

ELECTROMAGNETIC CLUTCHES & BRAKES

SPEED CHANGERS & REDUCERS

INVERTERS

LINEAR SHAFT DRIVES

TORQUE LIMITERS

ROSTA

## SERIES

Metal Disc Couplings  
**SERVOFLEX**

High-rigidity Couplings  
**SERVORIGID**

Metal Slit Couplings  
**HELI-CAL**

Metal Coil Spring Couplings  
**BAUMANNFLEX**

Pin Bushing Couplings  
**PARAFLEX**

Link Couplings  
**SCHMIDT**

Dual Rubber Couplings  
**STEPFLEX**

Jaw Couplings  
**MIKI PULLEY STARFLEX**

Jaw Couplings  
**SPRFLEX**

Plastic Bellows Couplings  
**BELLOWFLEX**

Rubber and Plastic Couplings  
**CENTAFLEX**

## MODELS

SFC

SFS

SFF

SFM

SFH

## Standard Bore Diameter

Model	Nominal diameter	Standard bore diameter d1 · d2 [mm]																					
		12	14	15	16	17	18	19	20	22	24	25	28	30	32	35	38	40	42	45	48	50	55
SFM-060SS-□B-□B-60N	d1	●	●	●	●	●	●	●															
	d2	●	●	●	●	●	●	●	●	●	●	●	●	●									
SFM-060SS-□B-□B-80N	d1								●	●	●	●	●	●									
	d2								●	●	●	●	●	●	●								
SFM-070SS-□B-□B-90N	d1						●	●															
	d2						●	●	●	●	●	●	●	●	●	●							
SFM-070SS-□B-□B-100N	d1								●	●	●	●	●	●	●	●							
	d2								●	●	●	●	●	●	●	●	●						
SFM-080SS-□B-□B-150N	d1									●	●	●	●	●	●	●							
	d2									●	●	●	●	●	●	●	●						
SFM-080SS-□B-□B-200N	d1									●	●	●	●	●	●	●	●						
	d2									●	●	●	●	●	●	●	●	●					
SFM-090SS-□B-□B-250N	d1											●	●										
	d2											●	●	●	●	●	●	●	●				
SFM-090SS-□B-□B-300N	d1													●	●	●	●	●	●				
	d2													●	●	●	●	●	●	●			
SFM-100SS-□B-□B-450N	d1														●	●	●	●	●	●	●	●	
	d2														●	●	●	●	●	●	●	●	●
SFM-120SS-□B-□B-600N	d1															●	●	●	●	●	●	●	●
	d2															●	●	●	●	●	●	●	●

\* The bore diameters marked with ● are supported as standard bore diameter.

## Balance correction

Model (size)	Balance classification	Supported rotational speed [min <sup>-1</sup> ]				
		10000 or less	15000 or less	18000 or less	20000 or less	24000 or less
SFM-060SS	G6.3 · G2.5	●	●	●	●	●
SFM-070SS	G6.3 · G2.5	●	●	●	●	●
SFM-080SS	G6.3 · G2.5	●	●	●	●	●
SFM-090SS	G6.3 · G2.5	●	●	●	●	●
SFM-100SS	G6.3 · G2.5	●	●	●	●	●
SFM-120SS	G6.3 · G2.5	●	●	●	●	●

\* We will perform balance correction for supported rotational speeds marked with ●.

## How to Place an Order

### SFM-080SS-25BK-30BK-200N-G2.5/24000

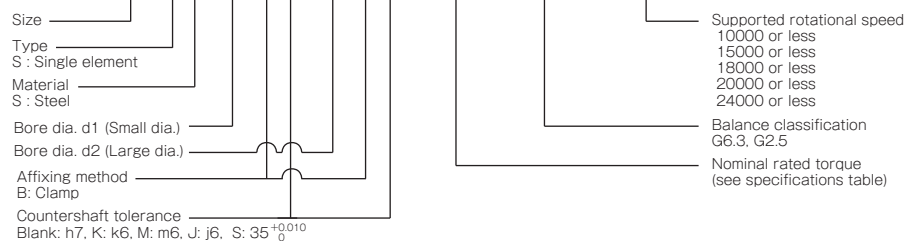

# SFM Types Wedge Coupling

## Specifications

Model	Rated torque [N·m]	Misalignment			Max. rotation speed [min <sup>-1</sup> ]	Torsional stiffness [N·m/rad]	Axial stiffness [N/mm]	Moment of inertia [kg·m <sup>2</sup> ]	Mass [kg]
		Parallel [mm]	Angular [°]	Axial [mm]					
SFM-070SS-□K-□K-100N	100	0.02	1	± 0.5	24000	240000	484	0.66 × 10 <sup>-3</sup>	0.92
SFM-080SS-□K-□K-150N	150	0.02	1	± 0.5	24000	120000	96	1.21 × 10 <sup>-3</sup>	1.03
SFM-080SS-□K-□K-200N	200	0.02	1	± 0.5	24000	310000	546	1.11 × 10 <sup>-3</sup>	1.26
SFM-090SS-□K-□K-300N	300	0.02	1	± 0.6	24000	520000	321	1.75 × 10 <sup>-3</sup>	1.48
SFM-100SS-□K-□K-450N	450	0.02	1	± 0.65	20000	740000	540	2.56 × 10 <sup>-3</sup>	1.87
SFM-120SS-□K-□K-600N	600	0.02	1	± 0.8	20000	970000	360	5.33 × 10 <sup>-3</sup>	2.50
SFM-140SS-□K-□K-800N	800	0.02	1	± 1.0	20000	1400000	360	10.28 × 10 <sup>-3</sup>	4.66
SFM-140SS-□K-□K-1000N	1000	0.02	1	± 1.0	20000	1400000	360	14.70 × 10 <sup>-3</sup>	5.01

\* Torsional stiffness values given are calculated for the element alone.  
 \* The moment of inertia and mass are measured for the maximum bore diameter.

## Dimensions

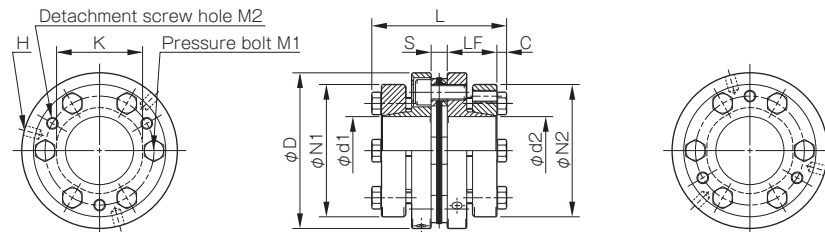

Model	d1 [mm]	d2 [mm]	D [mm]	L [mm]	N1 · N2 [mm]	LF [mm]	S [mm]	C [mm]	K [mm]	H [mm]	M1 Qty - Nominal dia.	M1 Tightening torque [N · m]	M2 Qty - Nominal dia.
SFM-070SS-□K-□K-100N	18 · 19	18 · 19	68	62.9	53	23.5	5.9	5	38	3-5.1	6-M6	10	3-M6
	20 · 22 · 24 · 25	20 · 22 · 24 · 25			58								
	28 · 30	28 · 30			63								
	32 · 35	32 · 35			68								
SFM-080SS-□K-□K-150N	22 · 24 · 25	22 · 24 · 25	78	69.3	58	25.5	8.3	5	37	4-5.1	4-M6	10	2-M6
	28 · 30	28 · 30			63								
	32 · 35	32 · 35			68								
	—	38			73								
SFM-080SS-□K-□K-200N	22 · 24 · 25	22 · 24 · 25	78	68.7	58	25.5	7.7	5	42	3-5.1	6-M6	10	3-M6
	28 · 30	28 · 30			63								
	32 · 35	32 · 35			68								
	38	38			73								
SFM-090SS-□K-□K-300N	28 · 30	28 · 30	88	69.3	63	25.5	8.3	5	50	3-6.8	6-M6	10	3-M6
	32 · 35	32 · 35			68								
	38 · 40 · 42	38 · 40 · 42			73								
	45	45			78								
SFM-100SS-□K-□K-450N	48	48	98	75.2	83	27.5	10.2	5	56	3-6.8	6-M6	10	3-M6
	32 · 35	32 · 35			68								
	38 · 40 · 42	38 · 40 · 42			73								
	45	45			78								
SFM-120SS-□K-□K-600N	48 · 50	48 · 50	118	75.2	83	27.5	10.2	5	68	3-6.8	6-M6	10	3-M6
	35	35			68								
	38 · 40 · 42	38 · 40 · 42			73								
	45	45			78								
	48 · 50 · 52	48 · 50 · 52			83								
	55	55			88								
SFM-140SS-□K-□K-800N	60 · 62 · 65	60 · 62 · 65	138	94.6	98	36.5	10.6	5.5	78	3-8.6	6-M8	24	3-M8
	—	70			108								
	35 · 38	35 · 38			83								
	40 · 42 · 45	40 · 42 · 45			88								
	—	48 · 50 · 52			98								
	—	55 · 60			108								
SFM-140SS-□K-□K-1000N	—	62 · 65 · 70	138	94.6	118	36.5	10.6	5.5	78	3-8.6	6-M8	24	3-M8
	—	75 · 80			128								
	48 · 50 · 52	48 · 50 · 52			98								
	55 · 60	55 · 60			108								
	62 · 65 · 70	62 · 65 · 70			118								
	75	75 · 80			128								

\* The nominal diameters of the pressure bolt M1 and detachment screw hole M2 are equal to the quantity minus the nominal diameter of the screw threads. The quantities of H, M1 and M2 are the same as the quantity for a hub on one side.

## COUPLINGS

ETP BUSHINGS

ELECTROMAGNETIC CLUTCHES & BRAKES

SPEED CHANGERS & REDUCERS

INVERTERS

LINEAR SHAFT DRIVES

TORQUE LIMITERS

ROSTA

## SERIES

Metal Disc Couplings  
**SERVOFLEX**

High-rigidity Couplings  
**SERVORIGID**

Metal Slit Couplings  
**HELI-CAL**

Metal Coil Spring Couplings  
**BAUMANNFLEX**

Pin Bushing Couplings  
**PARAFLEX**

Link Couplings  
**SCHMIDT**

Dual Rubber Couplings  
**STEPFLEX**

Jaw Couplings  
**MIKI PULLEY STARFLEX**

Jaw Couplings  
**SPRFLEX**

Plastic Bellows Couplings  
**BELLOWFLEX**

Rubber and Plastic Couplings  
**CENTAFLEX**

## MODELS

SFC

SFS

SFF

SFM

SFH

## Standard Bore Diameter

Model	Nominal diameter	Standard bore diameter d1 · d2 [mm]																							
		18	19	20	22	24	25	28	30	32	35	38	40	42	45	48	50	52	55	60	62	65	70	75	80
SFM-070SS-□K-□K-100N	d1	●	●	●	●	●	●	●	●	●	●														
	d2	●	●	●	●	●	●	●	●	●	●														
SFM-080SS-□K-□K-150N	d1				●	●	●	●	●	●	●														
	d2				●	●	●	●	●	●	●	●													
SFM-080SS-□K-□K-200N	d1				●	●	●	●	●	●	●	●													
	d2				●	●	●	●	●	●	●	●	●												
SFM-090SS-□K-□K-300N	d1						●	●	●	●	●	●	●	●	●										
	d2						●	●	●	●	●	●	●	●	●	●									
SFM-100SS-□K-□K-450N	d1								●	●	●	●	●	●	●	●	●								
	d2								●	●	●	●	●	●	●	●	●	●							
SFM-120SS-□K-□K-600N	d1									●	●	●	●	●	●	●	●	●	●	●	●	●	●	●	●
	d2									●	●	●	●	●	●	●	●	●	●	●	●	●	●	●	●
SFM-140SS-□K-□K-800N	d1										●	●	●	●	●										
	d2										●	●	●	●	●	●	●	●	●	●	●	●	●	●	●
SFM-140SS-□K-□K-1000N	d1												●	●	●	●	●	●	●	●	●	●	●	●	●
	d2												●	●	●	●	●	●	●	●	●	●	●	●	●

\* The bore diameters marked with ● are supported as standard bore diameter.

## Balance correction

Model (size)	Balance classification	Supported rotational speed [min <sup>-1</sup> ]				
		10000 or less	15000 or less	18000 or less	20000 or less	24000 or less
SFM-070SS	G6.3 · G2.5	●	●	●	●	●
SFM-080SS	G6.3 · G2.5	●	●	●	●	●
SFM-090SS	G6.3 · G2.5	●	●	●	●	●
SFM-100SS	G6.3 · G2.5	●	●	●	●	●
SFM-120SS	G6.3 · G2.5	●	●	●	●	●
SFM-140SS	G6.3 · G2.5	●	●	●	●	●

\* We will perform balance correction for supported rotational speeds marked with ●.

## How to Place an Order

### SFM-080SS-25KK-30KK-200N-G2.5/24000

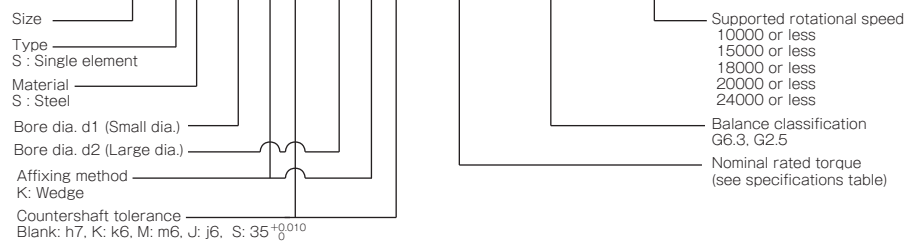

# SFM Types

## Items Checked for Design Purposes

### Special Items to Take Note of

You should note the following to prevent any problems.

- (1) Always be careful of parallel, angular, and axial misalignment.
- (2) Always tighten bolts with the specified torque.

### Precautions for Handling

Couplings are assembled at high accuracy using a special mounting jig to ensure accurate concentricity of left and right internal diameters. Take extra precautions when handling couplings, should strong shocks be given on couplings, it may affect mounting accuracy and cause the parts to break during use.

- (1) Couplings are designed for use within an operating temperature range of -30°C to 120°C. Although the couplings are designed to be waterproof and oilproof, do not subject them to excessive amounts of water and oil as it may cause part deterioration.
- (2) Handle the element with care as it is made of a thin stainless steel metal disc, also making sure to be careful so as not to injure yourself.
- (3) Do not tighten up clamping bolts or pressure bolts until after inserting the mounting shaft.

### Mounting (Clamping)

- (1) Check that coupling clamping bolts have been loosened and remove any rust, dust, oil residue, etc. from the inner diameter surfaces of the shaft and couplings. In particular, never allow oil or grease containing antifricition or other agent (molybdenum-, silicon-, or fluorine-based), which would dramatically affect the friction coefficient, to contact the surface.
- (2) Be careful when inserting the couplings onto the shaft so as not to apply excessive force of compression or tensile force to the element.
- (3) Ensure that the length of the coupling inserted onto the motor shaft touches the shaft for the entire length of the clamping hub of the coupling (LF dimension), as shown in the diagram below, and position it so that it does not interfere with the elements, spacers or the other shaft. Then temporarily tighten the two clamping bolts, tightening them alternately until the coupling cannot be manually rotated.

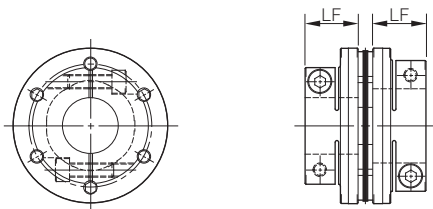

Model (Clamping)	LF dimension [mm]
SFM-060	24
SFM-070	25
SFM-080	30
SFM-090	30
SFM-100	40
SFM-120	40

- (4) Hold a dial gauge against the outer diameter of the clamping hub on the motor shaft side (the surface processed simultaneously with the inner diameter), and then tighten the two clamping bolts while turning the motor shaft by hand and adjusting the difference in the runout values at A and B in the figure below is 0.02 mm or less (and as close to 0 as possible).

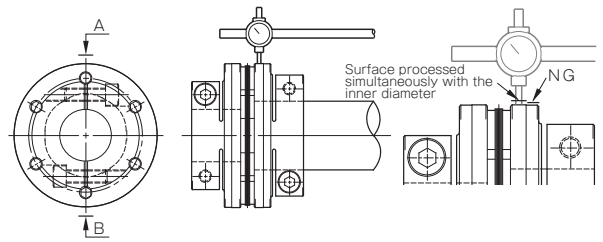

- (5) Alternately fasten the two clamping bolts as you adjust them, and finish by tightening both bolts to the appropriate tightening torque of the following table, using a calibrated torque wrench. Since it is fastened by two clamping bolts, tightening one bolt before the other will place more than the prescribed axial force on the bolt tightened first when the other bolt is tightened. Be sure to tighten them alternately, a little at a time.

Clamping bolt nominal diameter	Tightening torque [N·m]
M5	7
M6	14
M8	34
M10	68

- (6) Mount the motor, to which the coupling has already been mounted, on the body of the machinery. At that time, adjust the motor mounting position (centering location) while inserting the coupling onto the driven shaft, being alert to undue forces on the element such as compression or pulling.
- (7) Make the length of the driven shaft inserted into the coupling connect to the shaft for the length of the LF dimension (described above), alternately tighten the two clamping bolts, and provisionally tighten enough that the coupling cannot be manually rotated.
- (8) In addition, keep the dimension between clamping hub faces (the S dimension in the diagram) to within the allowable misalignment of the axial displacement with respect to a reference value. Note that the tolerance values were calculated based on the assumption that both the level of parallel misalignment and angular deflection are zero. Adjust to keep this value as low as possible.

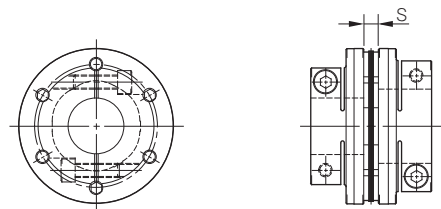

Model (Clamping)	S dimension [mm]
SFM-060	5.4
SFM-070	5.9
SFM-080 (-150N)	8.3
SFM-080 (-200N)	7.7
SFM-090	8.3
SFM-100	10.2
SFM-120	10.2

- (9) Adjust runout using the same procedure as for the motor shaft side, and then finish by tightening the clamping bolts to the appropriate tightening torque.
- (10) To protect against initial loosening of the clamping bolt, we recommend operating for a set period of time and then retightening to the appropriate tightening torque.

## Mounting (Wedge Coupling)

- (1) Check that coupling pressure bolts have been loosened and remove any rust, dust, oil residue, etc. from the inner diameter surfaces of the shaft and couplings. In particular, never allow oil or grease containing antifriction or other agent (molybdenum-, silicon-, or fluorine-based), which would dramatically affect the friction coefficient, to contact the surface.
- (2) Be careful when inserting the couplings into the shaft so as not to apply excessive force of compression or tensile force to the element.
- (3) Insert each coupling far enough onto the motor shaft that it touches the shaft along the entire length of the coupling flange (LF dimension), as shown in the diagram below. Position it so that it does not interfere with the elements, spacers or the other shaft and then hold it in place.

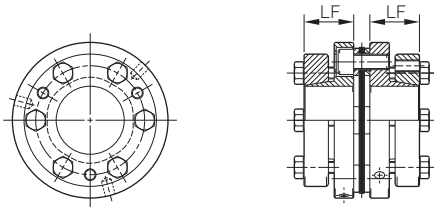

Model (Wedge coupling)	LF dimension [mm]
SFM-070	23.5
SFM-080	25.5
SFM-090	25.5
SFM-100	27.5
SFM-120	27.5
SFM-140	36.5

- (4) Using the drive pin hole, lightly tighten the pressure bolt on the diagonal.

- (5) Touch the dial gauge to the flange end face or outer diameter on the motor shaft side. Then, while gently rotating the motor shaft manually, adjust the flange periphery and end face by hammering until the runout is as close to zero as possible.

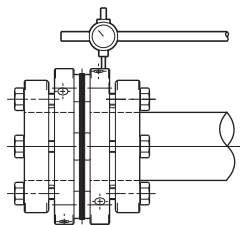

- (6) Sequentially fasten the pressure bolts while doing hammering adjustments, and then use a calibrated torque wrench to tighten all the pressure bolts to the appropriate tightening torques below. See the following figure for the tightening procedure for the pressure bolts. Try to tighten them evenly.

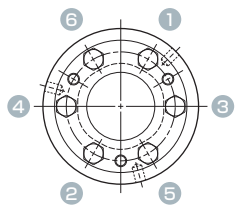

Pressure bolt nominal diameter	Tightening torque [N·m]
M6	10
M8	24

- (7) Tighten the motor shaft's pressure bolts at the nominal torque and check that the runout value is low.
- (8) Mount the motor, to which the coupling has already been mounted, on the body of the machinery. At that time, adjust the motor mounting position (centering location) while inserting the coupling onto the driven shaft, being alert to any deformation of the disc, etc. Make the length of the driven shaft inserted into the coupling be in contact with the entire length of the coupling flange (LF dimension), and maintain it at that position.

- (9) Keep the width of the dimension between flange faces (S dimension in the diagram) within the allowable error range for axial misalignment with respect to the reference value. Note that the tolerance values were calculated based on the assumption that both the level of parallel misalignment and angular deflection are zero. Adjust to keep this value as low as possible.

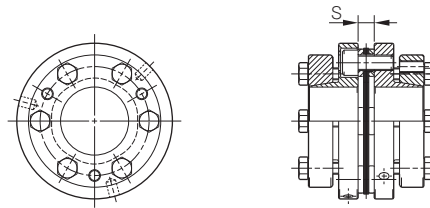

Model	S dimension [mm]
SFM-070	5.9
SFM-080 (-150N)	8.3
SFM-080 (-200N)	7.7
SFM-090	8.3
SFM-100	10.2
SFM-120	10.2
SFM-140	10.6

- (10) Tighten the pressure bolts on the driven shaft in order using the same procedure as for the pressure bolts on the motor shaft side, and then finish by tightening to the appropriate tightening torque.

- (11) To protect against initial loosening of the pressure bolt, we recommend operating for a set period of time and then retightening to the appropriate tightening torque.

### Important when Combining for High-Revolution (Main Shaft) Applications

For high-revolution applications such as a machining center main shaft, vibration can become an issue.

One cause of vibration at high revolutions is misalignment of shaft axes when combining the spindle motor and the main shaft, with vibration still occurring even with balance correction of the coupling itself.

While it is possible to allow for some misalignment occurring as parallel, angular, or axial displacement, it is particularly important to take care with misalignment with high-revolution applications. Be sure to perform axial adjustment during assembly and field balance correction after assembly.

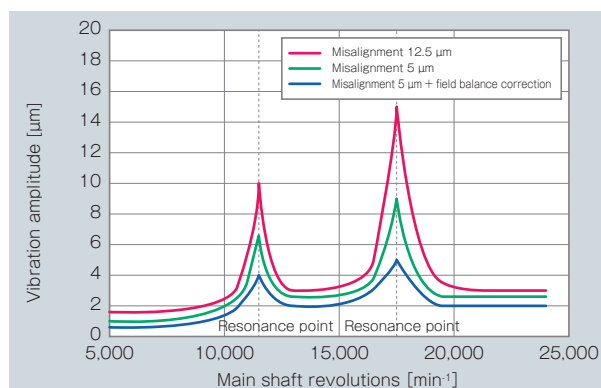

\*Couplings used in the above measurements had undergone balance correction on an individual basis.

## COUPLINGS

ETP BUSHINGS

ELECTROMAGNETIC CLUTCHES & BRAKES

SPEED CHANGERS & REDUCERS

INVERTERS

LINEAR SHAFT DRIVES

TORQUE LIMITERS

ROSTA

## SERIES

Metal Disc Couplings	SERVOFLEX
	High-rigidity Couplings
	SERVORIGID
	Metal Slit Couplings
Metal Couplings	HELI-CAL
	Metal Coil Spring Couplings
Metal Couplings	BAUMANNFLEX
	Pin Bushing Couplings
Metal Couplings	PARAFLEX
	Link Couplings
Metal Couplings	SCHMIDT
	Dual Rubber Couplings
Rubber and Plastic Couplings	STEPFLEX
	Jaw Couplings
Rubber and Plastic Couplings	MIKI PULLEY
	STARFLEX
Rubber and Plastic Couplings	Jaw Couplings
	SPRFLEX
Rubber and Plastic Couplings	Plastic Bellows Couplings
	BELLOWFLEX
Rubber and Plastic Couplings	Rubber and Plastic Couplings
	CENTAFLEX

## MODELS

SFC

SFS

SFF

SFM

SFH



# SFM Types

## Items Checked for Design Purposes

### Removal

- (1) Check to confirm that there is no torque or axial load being applied to the coupling. There may be cases where a torque is applied to the coupling, particularly when the safety brake is being used. Make sure to verify that this is not occurring before removing parts.
- (2) Loosen all the clamping bolts or pressure bolts (loosen pressure bolts until the gap between bearing seat and sleeve is about 2mm).
- (3) For clamping type, release the fastening to the shaft by sufficiently loosening all clamping bolts. Note that grease has been applied to the clamping bolts, so do not remove them all the way.
- (4) In the case of a wedge coupling system that tightens a pressure bolt from the axial direction, the sleeve will be self-locking, so the coupling between flange and shaft cannot be released simply by loosening the pressure bolt. (Note that in some cases, a coupling can be released by loosening a pressure bolt.) For that reason, when designing devices, a space must be installed for inserting a detachment screw.

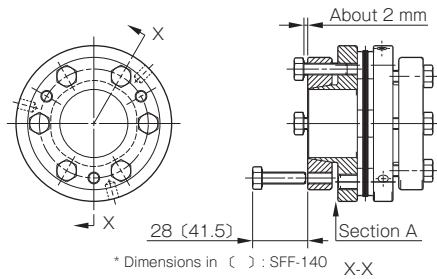

- (5) Pull out three of the pressure bolts (two 080, 150 N) loosened in step (2), insert them into the detachment screw holes on the sleeve, and tighten them in order, a little at a time. The coupling will be released.
- (6) If there is no space in the axial direction, insert the tip of a flathead screwdriver or the like into part A and lightly tap perpendicular to the shaft or use it as a lever to pry off the coupling. Use appropriate caution to not damage the coupling body or the pressure bolts.

### Suitable Torque Screwdriver/Torque Wrench

#### Clamping bolt

Nominal bolt diameter	Tightening torque [N · m]	Torque screwdriver/wrench	Hexagon bit/head	Coupling size
M5	7	N10LTDK	SB 4mm	060
M6	14	N25LCK	25HCK 5mm	060 · 070 · 080
M8	34	N50LCK	50HCK 6mm	080 · 090
M10	68	N100SPCK × 68N · m	100HCK 8mm	100 · 120

\* Torque screwdriver (wrench)/bit (head) models are those of Nakamura Mfg. Co., Ltd.

#### Pressure bolt

Nominal bolt diameter	Tightening torque [N · m]	Torque wrench	Spanner head	Coupling size
M6	10	N125PCK × 10N · m	25SCK 10mm	070 ~ 120
M8	24	N50SPCK × 24N · m	50SCK 13mm	140

\* Torque wrench/spanner head models are those of Nakamura Mfg. Co., Ltd.

### Differences in Torsional Stiffness due to Element Shape

Elements used by SFM models may be either square or hexagonal. Since torque is transmitted by coupling the hubs to each other via the element, torsional stiffness is higher in couplings that use hexagonal elements transmitting torque with six bolts, at the expense of some flexibility. Choose your element shape accordingly.

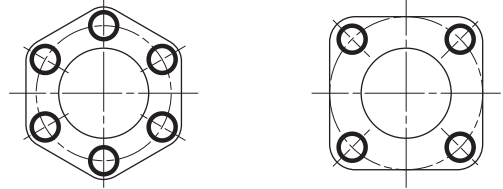

Model (nominal rated torque)	Element shape
SFM-060	Hexagonal
SFM-070	Hexagonal
SFM-080 (-150N)	Square
SFM-080 (-200N)	Hexagonal
SFM-090	Hexagonal
SFM-100	Hexagonal
SFM-120	Hexagonal
SFM-140	Hexagonal

### Clamping and Wedge Coupling in Combination

For the range of common sizes between clamping and wedge coupling (070 - 120), a common element is used per each size allowing you to use them in combination.

When specifying bore diameters in this instance, specify d1: clamping, d2: wedge coupling in that order, regardless of larger and smaller bore diameters.

#### Example) SFM-080SS-30B-25K-200N-G2.5/24000



Rated torques after combination are given for the clamping side. See the table below.

d1 clamping (designation B)		d2 wedge coupling (designation K)		Rated torque after combination [N·m]
Model	Bore diameter range [mm]	Model	Bore diameter range [mm]	
SFM-070 (-90N)	18 · 19	SFM-070 (-100N)	18 ~ 35	90
SFM-070 (-100N)	20 ~ 35	SFM-070 (-100N)	18 ~ 35	100
SFM-080 (-150N)	22 ~ 35	SFM-080 (-150N)	22 ~ 38	150
SFM-080 (-200N)	22 ~ 38	SFM-080 (-200N)	22 ~ 38	200
SFM-090 (-250N)	25 · 28	SFM-090 (-300N)	28 ~ 48	250
SFM-090 (-300N)	30 ~ 42	SFM-090 (-300N)	28 ~ 48	300
SFM-100 (-450N)	32 ~ 48	SFM-100 (-450N)	32 ~ 50	450
SFM-120 (-600N)	32 ~ 55	SFM-120 (-600N)	35 ~ 70	600





## Selection Procedures

(1) Find the torque,  $T_a$ , applied to the coupling using the output capacity,  $P$ , of the driver and the usage rotation speed,  $n$ .

$$T_a \text{ [N}\cdot\text{m]} = 9550 \times \frac{P \text{ [kW]}}{n \text{ [min}^{-1}\text{]}}$$

(2) Determine the factor  $K$  from the load properties, and find the corrected torque,  $T_d$ , applied to the coupling.

$$T_d \text{ [N}\cdot\text{m]} = T_a \text{ [N}\cdot\text{m]} \times K \text{ (Refer to the table below for values)}$$

	Constant	Vibrations: Small	Vibrations: Medium	Vibrations: Large
Load properties				
K	1.0	1.25	1.75	2.25

For servo motor drive, multiply the maximum torque,  $T_s$ , by the usage factor  $K = 1.2$  to  $1.5$ .

$$T_d \text{ [N}\cdot\text{m]} = T_s \text{ [N}\cdot\text{m]} \times (1.2 \sim 1.5)$$

For high-revolution applications such as a machining center main shaft, it is necessary to set a high safety factor unlike common feed screw systems.

Multiply the maximum torque of spindle motor:  $T_s$  by the service factor:  $K=3$  to  $3.6$ .

$$T_d \text{ [N}\cdot\text{m]} = T_s \text{ [N}\cdot\text{m]} \times (3 \sim 3.6)$$

(3) Set the size so that the rated coupling torque,  $T_n$ , is higher than the corrected torque,  $T_d$ .

$$T_n \text{ [N}\cdot\text{m]} \geq T_d \text{ [N}\cdot\text{m]}$$

(4) Check that the mount shaft is no larger than the maximum bore diameter of the coupling.

\* Contact Miki Pulley for assistance with any device experiencing extreme periodic vibrations.

### COUPLINGS

ETP BUSHINGS

ELECTROMAGNETIC CLUTCHES & BRAKES

SPEED CHANGERS & REDUCERS

INVERTERS

LINEAR SHAFT DRIVES

TORQUE LIMITERS

ROSTA

### SERIES

Metal Couplings	Metal Disc Couplings <b>SERVOFLEX</b>
	High-rigidity Couplings <b>SERVORIGID</b>
	Metal Slit Couplings <b>HELI-CAL</b>
	Metal Coil Spring Couplings <b>BAUMANNFLEX</b>
	Pin Bushing Couplings <b>PARAFLEX</b>
Rubber and Plastic Couplings	Link Couplings <b>SCHMIDT</b>
	Dual Rubber Couplings <b>STEPFLEX</b>
	Jaw Couplings <b>MIKI PULLEY STARFLEX</b>
	Jaw Couplings <b>SPRFLEX</b>
	Plastic Bellows Couplings <b>BELLOWFLEX</b>
	Rubber and Plastic Couplings <b>CENTAFLEX</b>

### MODELS

SFC

SFS

SFF

SFM

SFH

# SFH S Types Single Element Type

## Specification (SFH-□S) Pilot Bore/Key or Set Screw

Model	Rated torque [N·m]	Misalignment		Max. rotation speed [min <sup>-1</sup> ]	Torsional stiffness [N·m/rad]	Axial stiffness [N/mm]	Moment of inertia [kg·m <sup>2</sup> ]	Mass [kg]
		Angular [°]	Axial [mm]					
SFH-150S	1000	1	± 0.4	5900	1500000	244	12.60 × 10 <sup>-3</sup>	4.71
SFH-170S	1300	1	± 0.5	5100	2840000	224	26.88 × 10 <sup>-3</sup>	7.52
SFH-190S	2000	1	± 0.5	4700	3400000	244	43.82 × 10 <sup>-3</sup>	10.57
SFH-210S	4000	1	± 0.55	4300	4680000	508	68.48 × 10 <sup>-3</sup>	13.78
SFH-220S	5000	1	± 0.6	4000	5940000	448	102.53 × 10 <sup>-3</sup>	18.25
SFH-260S	8000	1	± 0.7	3400	10780000	612	233.86 × 10 <sup>-3</sup>	29.66

\* Max. rotation speed does not take into account dynamic balance.  
 \* The moment of inertia and mass are measured for the maximum bore diameter.

## Dimensions (SFH-□S) Pilot Bore/Key or Set Screw

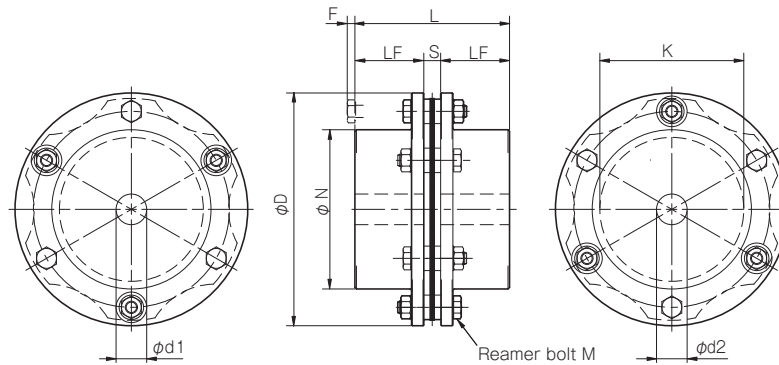

Unit [mm]

Model	d1 - d2			D	N	L	LF	S	F	K	M
	Pilot bore	Min.	Max.								
SFH-150S	20	22	70	152	104	101	45	11	5	94	6-M8 × 36
SFH-170S	25	28	80	178	118	124	55	14	6	108	6-M10 × 45
SFH-190S	30	32	85	190	126	145	65	15	10	116	6-M12 × 54
SFH-210S	35	38	90	210	130	165	75	15	8	124	6-M16 × 60
SFH-220S	45	48	100	225	144	200	90	20	-2	132	6-M16 × 60
SFH-260S	50	55	115	262	166	223	100	23	11	150	6-M20 × 80

\* Pilot bores are to be drilled into the part. See the standard hole-drilling standards of P.84 for information on bore drilling.  
 \* The nominal diameter of the reamer bolt is equal to the quantity minus the nominal diameter of the screw threads times the nominal length.

**How to Place an Order**

### SFH-150S-38H-38H

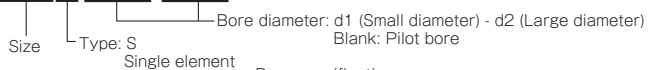

Bore specifications  
 Blank: Compliant with the old JIS standards (class 2)  
 H: Compliant with the new JIS standards  
 N: Compliant with the new motor standards

## COUPLINGS

ETP BUSHINGS

ELECTROMAGNETIC CLUTCHES & BRAKES

SPEED CHANGERS & REDUCERS

INVERTERS

LINEAR SHAFT DRIVES

TORQUE LIMITERS

ROSTA

## SERIES

Metal Couplings	Metal Disc Couplings <b>SERVOFLEX</b>
	High-rigidity Couplings <b>SERVORIGID</b>
	Metal Slit Couplings <b>HELI-CAL</b>
	Metal Coil Spring Couplings <b>BAUMANNFLEX</b>
	Pin Bushing Couplings <b>PARAFLEX</b>
Rubber and Plastic Couplings	Link Couplings <b>SCHMIDT</b>
	Dual Rubber Couplings <b>STEPFLEX</b>
	Jaw Couplings <b>MIKI PULLEY STARFLEX</b>
	Jaw Couplings <b>SPRFLEX</b>
	Plastic Bellows Couplings <b>BELLOWFLEX</b>
	Rubber and Plastic Couplings <b>CENTAFLEX</b>

## MODELS

SFC

SFS

SFF

SFM

SFH

## Specification (SFH-□S-□K-□K) Frictional Coupling

Model	Rated torque [N·m]	Misalignment		Max. rotation speed [min <sup>-1</sup> ]	Torsional stiffness [N·m/rad]	Axial stiffness [N/mm]	Moment of inertia [kg·m <sup>2</sup> ]	Mass [kg]
		Angular [°]	Axial [mm]					
SFH-150S	1000	1	± 0.4	5900	1500000	244	25.14 × 10 <sup>-3</sup>	8.95
SFH-170S	1300	1	± 0.5	5100	2840000	224	47.90 × 10 <sup>-3</sup>	12.53
SFH-190S	2000	1	± 0.5	4700	3400000	244	60.40 × 10 <sup>-3</sup>	14.21
SFH-210S	4000	1	± 0.55	4300	4680000	508	80.50 × 10 <sup>-3</sup>	16.12

\* Max. rotation speed does not take into account dynamic balance.

\* The moment of inertia and mass in the table are measured for the maximum bore diameter.

## Dimensions (SFH-□S-□K-□K) Frictional Coupling

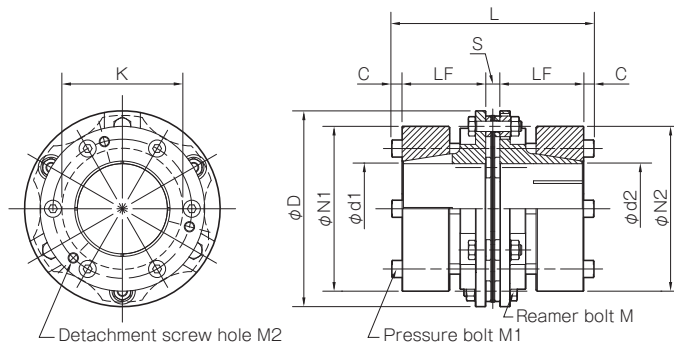

Model	D	L	d1 · d2	N1 · N2	LF	S	C	K	M	M1	M2
SFH-150S	152	157	38 · 40 · 42 · 45 · 50	108	65	11	8	94	6-M8 × 36	6-M8 × 60	3-M8
			55 · 56 · 60 · 65 · 70	128							
SFH-170S	178	160	38 · 40 · 42 · 45 · 50	108	65	14	8	108	6-M10 × 45	6-M8 × 60	3-M8
			55 · 56 · 60 · 65 · 70	128							
			75 · 80	148							
SFH-190S	190	175	38 · 40 · 42 · 45 · 50	108	70	15	10	116	6-M12 × 54	6-M10 × 65	3-M10
			55 · 56 · 60 · 65 · 70	128							
			75 · 80 · 85	148							
SFH-210S	210	181	38 · 40 · 42 · 45 · 50	108	73	15	10	124	6-M16 × 60	6-M10 × 65	3-M10
			55 · 56 · 60 · 65 · 70	128							
			75 · 80 · 85 · 90	148							

\* The nominal diameters of each bolt and tap are equal to the quantity minus the nominal diameter of the screw threads times the nominal length. The quantities for the pressure bolt M1 and detachment screw hole M2 are quantities for the hub on one side.

## Standard Bore Diameter

Model	Standard bore diameter d1, d2 [mm]															
	38	40	42	45	48	50	55	56	60	65	70	75	80	85	90	
SFH-150S	●	●	●	●	●	●	●	●	●	●	●					
SFH-170S	1100	1200	1250	●	●	●	●	●	●	●	●	●	●	●		
SFH-190S	1800	1900	●	●	●	●	●	●	●	●	●	●	●	●	●	
SFH-210S	1800	1900	2000	2150	2300	2400	2600	2650	2850	3100	3350	3600	3800	●	●	

\* The bore diameters marked with ● or numbers are supported as standard bore diameter.

\* Bore diameters whose fields contain numbers are restricted in their rated torque by the holding power of the shaft connection component because the bore diameter is small. The numbers indicate the rated torque value [N·m].

## How to Place an Order

### SFH-150S-38KK-42KK

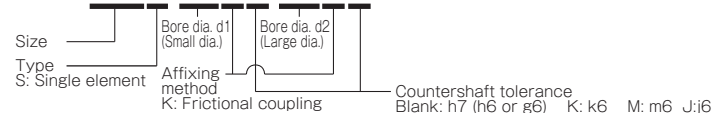

# SFH G Types Double Element/Floating Shaft Type

## Specification (SFH-□G) Pilot Bore/Key or Set Screw

Model	Rated torque [N·m]	Misalignment			Max. rotation speed [min <sup>-1</sup> ]	Torsional stiffness [N·m/rad]	Axial stiffness [N/mm]	Moment of inertia [kg·m <sup>2</sup> ]	Mass [kg]
		Parallel [mm]	Angular [°]	Axial [mm]					
SFH-150G	1000	1.4	1 (On one side)	± 0.8	5900	750000	122	21.87 × 10 <sup>-3</sup>	8.72
SFH-170G	1300	1.6	1 (On one side)	± 1.0	5100	1420000	112	51.07 × 10 <sup>-3</sup>	13.94
SFH-190G	2000	2.0	1 (On one side)	± 1.0	4700	1700000	122	81.58 × 10 <sup>-3</sup>	19.51
SFH-210G	4000	2.1	1 (On one side)	± 1.1	4300	2340000	254	125.50 × 10 <sup>-3</sup>	24.26
SFH-220G	5000	2.3	1 (On one side)	± 1.2	4000	2970000	224	176.91 × 10 <sup>-3</sup>	30.27
SFH-260G	8000	2.9	1 (On one side)	± 1.4	3400	5390000	306	433.47 × 10 <sup>-3</sup>	53.11

\* Max. rotation speed does not take into account dynamic balance.  
 \* The moment of inertia and mass are measured for the maximum bore diameter.

## Dimensions (SFH-□G) Pilot Bore/Key or Set Screw

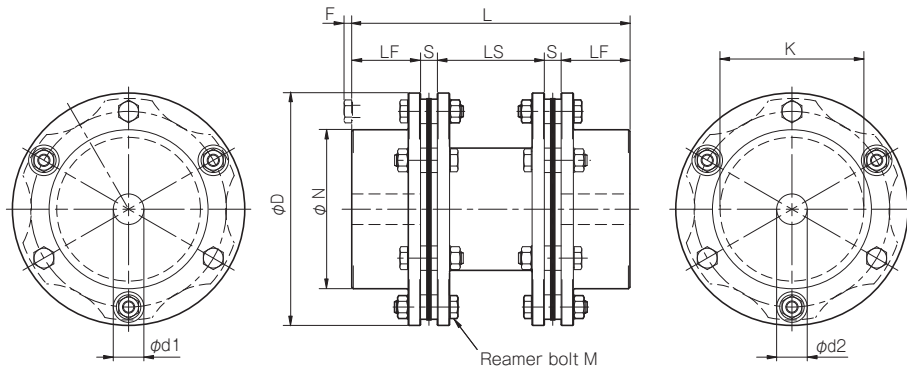

Unit [mm]

Model	d1 · d2			D	N	L	LF	LS	S	F	K	M
	Pilot bore	Min.	Max.									
SFH-150G	20	22	70	152	104	182	45	70	11	5	94	12-M8 × 36
SFH-170G	25	28	80	178	118	218	55	80	14	6	108	12-M10 × 45
SFH-190G	30	32	85	190	126	260	65	100	15	10	116	12-M12 × 54
SFH-210G	35	38	90	210	130	290	75	110	15	8	124	12-M16 × 60
SFH-220G	45	48	100	225	144	335	90	115	20	-2	132	12-M16 × 60
SFH-260G	50	55	115	262	166	391	100	145	23	11	150	12-M20 × 80

\* Pilot bores are to be drilled into the part. See the standard hole-drilling standards of P.84 for information on bore drilling.  
 \* If you require a product with an LS dimension other than that above, contact Miki Pulley with your required dimension [mm]. Please contact Miki Pulley for assistance if LS ≥ 1000.  
 \* The nominal diameter of the reamer bolt is equal to the quantity minus the nominal diameter of the screw threads times the nominal length.

### How to Place an Order

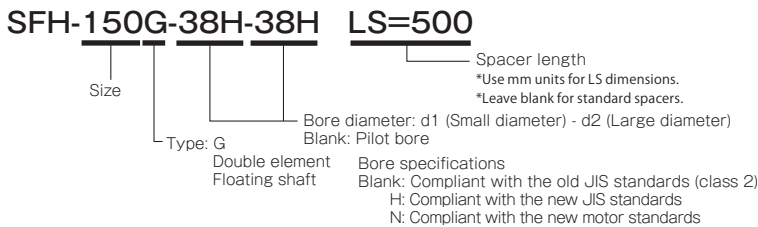

### Maximum LS Dimension When Used Vertically

Model	LS [mm]
SFH-150G	1100
SFH-170G	800
SFH-190G	900
SFH-210G	2000
SFH-220G	1900
SFH-260G	2500

\* When considering vertical use and the LS dimension is greater than that in the above table, consult Miki Pulley.

COUPLINGS

ETP BUSHINGS

ELECTROMAGNETIC CLUTCHES & BRAKES

SPEED CHANGERS & REDUCERS

INVERTERS

LINEAR SHAFT DRIVES

TORQUE LIMITERS

ROSTA

SERIES

Metal Disc Couplings	SERVOFLEX
	High-rigidity Couplings
	SERVORIGID
	Metal Slit Couplings
Metal Couplings	HELI-CAL
	Metal Coil Spring Couplings
	BAUMANNFLEX
Pin Bushing Couplings	PARAFLEX
	Link Couplings
Rubber and Plastic Couplings	SCHMIDT
	Dual Rubber Couplings
	STEPFLEX
	Jaw Couplings
	MIKI PULLEY STARFLEX
	Jaw Couplings
	SPRFLEX
	Plastic Bellows Couplings
	BELLOWFLEX
	Rubber and Plastic Couplings
CENTAFLEX	

MODELS

SFC

SFS

SFF

SFM

SFH

Specification (SFH-□G-□K-□K) Frictional Coupling

Model	Rated torque [N·m]	Misalignment			Max. rotation speed [min <sup>-1</sup> ]	Torsional stiffness [N·m/rad]	Axial stiffness [N/mm]	Moment of inertia [kg·m <sup>2</sup> ]	Mass [kg]
		Parallel [mm]	Angular [°]	Axial [mm]					
SFH-150G	1000	1.4	1 (On one side)	± 0.8	5900	750000	122	34.41 × 10 <sup>-3</sup>	12.96
SFH-170G	1300	1.6	1 (On one side)	± 1.0	5100	1420000	112	72.09 × 10 <sup>-3</sup>	18.95
SFH-190G	2000	2.0	1 (On one side)	± 1.0	4700	1700000	122	98.15 × 10 <sup>-3</sup>	23.14
SFH-210G	4000	2.1	1 (On one side)	± 1.1	4300	2340000	254	137.53 × 10 <sup>-3</sup>	26.61

\* Max. rotation speed does not take into account dynamic balance.  
 \* The moment of inertia and mass in the table are measured for the maximum bore diameter.

Dimensions (SFH-□G-□K-□K) Frictional Coupling

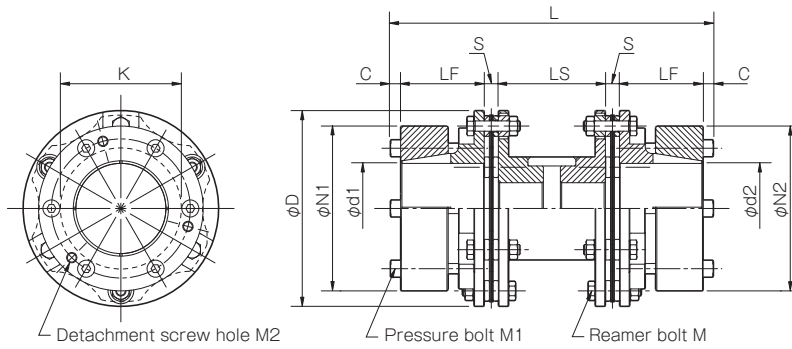

Model	D	L	d1 · d2		N1 · N2	LF	LS	S	C	K	M	M1	M2
			Unit [mm]										
SFH-150G	152	238	38 · 40 · 42 · 45 · 50		108	65	70	11	8	94	12-M8 × 36	6-M8 × 60	3-M8
			55 · 56 · 60 · 65 · 70		128								
SFH-170G	178	254	38 · 40 · 42 · 45 · 50		108	65	80	14	8	108	12-M10 × 45	6-M8 × 60	3-M8
			55 · 56 · 60 · 65 · 70		128								
			75 · 80		148								
SFH-190G	190	290	38 · 40 · 42 · 45 · 50		108	70	100	15	10	116	12-M12 × 54	6-M10 × 65	3-M10
			55 · 56 · 60 · 65 · 70		128								
			75 · 80 · 85		148								
SFH-210G	210	306	38 · 40 · 42 · 45 · 50		108	73	110	15	10	124	12-M16 × 60	6-M10 × 65	3-M10
			55 · 56 · 60 · 65 · 70		128								
			75 · 80 · 85 · 90		148								

\* If you require a product with an LS dimension other than that above, contact Miki Pulley with your required dimension [mm]. Please contact Miki Pulley for assistance if LS ≥ 1000.  
 \* The nominal diameters of each bolt and tap are equal to the quantity minus the nominal diameter of the screw threads times the nominal length. The quantities for the pressure bolt M1 and detachment screw hole M2 are quantities for the hub on one side.

Standard Bore Diameter

Model	Standard bore diameter d1, d2 [mm]														
	38	40	42	45	48	50	55	56	60	65	70	75	80	85	90
SFH-150G	●	●	●	●	●	●	●	●	●	●	●	●	●	●	●
SFH-170G	1100	1200	1250	●	●	●	●	●	●	●	●	●	●	●	●
SFH-190G	1800	1900	●	●	●	●	●	●	●	●	●	●	●	●	●
SFH-210G	1800	1900	2000	2150	2300	2400	2600	2650	2850	3100	3350	3600	3800	●	●

\* The bore diameters marked with ● or numbers are supported as standard bore diameter.  
 \* Bore diameters whose fields contain numbers are restricted in their rated torque by the holding power of the shaft connection component because the bore diameter is small. The numbers indicate the rated torque value [N·m].

How to Place an Order

SFH-150G-38KK-42KK LS=500

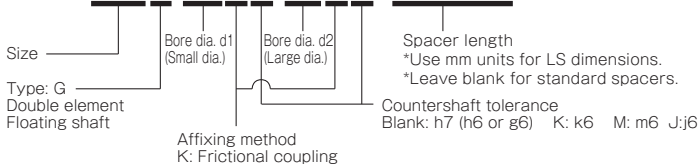

Maximum LS Dimension When Used Vertically

Model	LS [mm]
SFH-150G	1100
SFH-170G	800
SFH-190G	900
SFH-210G	2000

\* When considering vertical use and the LS dimension is greater than that in the above table, consult Miki Pulley.

# SFH Models

## Standard Hole-Drilling Standards

- Positioning precision for keyway milling is determined by sight, so contact Miki Pulley when the keyway requires a positioning precision for a particular flange hub.
- Set screw positions are not on the same plane.
- The set screws are included with the product.
- Consult the technical documentation at the end of this volume for standard dimensions for bore processing other than those given here.

### ■ SFH S

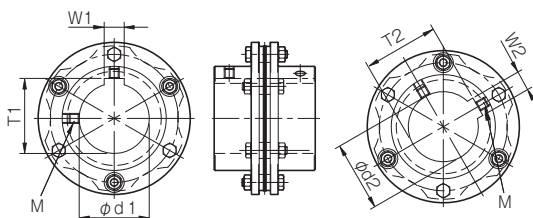

### ■ SFH G

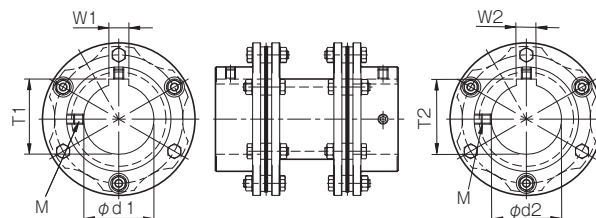

Unit [mm]

Models compliant with the old JIS standards (class 2)					Models compliant with the new JIS standards					Models compliant with the new motor standards				
Nominal bore diameter	Nominal bore diameter [d1 · d2]	Keyway width [W1 · W2]	Keyway height [T1 · T2]	Set screw hole [M]	Nominal bore diameter	Nominal bore diameter [d1 · d2]	Keyway width [W1 · W2]	Keyway height [T1 · T2]	Set screw hole [M]	Nominal bore diameter	Nominal bore diameter [d1 · d2]	Keyway width [W1 · W2]	Keyway height [T1 · T2]	Set screw hole [M]
Tolerance	H7	E9	—	—	Tolerance	H7	H9	—	—	Tolerance	G7, F7	H9	—	—
22	22 <sup>+0.021</sup> <sub>0</sub>	7 <sup>+0.061</sup> <sub>+0.025</sub>	25.0 <sup>+0.3</sup> <sub>0</sub>	2-M6	22H	22 <sup>+0.021</sup> <sub>0</sub>	6 <sup>+0.030</sup> <sub>0</sub>	24.8 <sup>+0.3</sup> <sub>0</sub>	2-M5	—	—	—	—	—
24	24 <sup>+0.021</sup> <sub>0</sub>	7 <sup>+0.061</sup> <sub>+0.025</sub>	27.0 <sup>+0.3</sup> <sub>0</sub>	2-M6	24H	24 <sup>+0.021</sup> <sub>0</sub>	8 <sup>+0.036</sup> <sub>0</sub>	27.3 <sup>+0.3</sup> <sub>0</sub>	2-M6	24N	24 <sup>+0.028</sup> <sub>+0.007</sub>	8 <sup>+0.036</sup> <sub>0</sub>	27.3 <sup>+0.3</sup> <sub>0</sub>	2-M6
25	25 <sup>+0.021</sup> <sub>0</sub>	7 <sup>+0.061</sup> <sub>+0.025</sub>	28.0 <sup>+0.3</sup> <sub>0</sub>	2-M6	25H	25 <sup>+0.021</sup> <sub>0</sub>	8 <sup>+0.036</sup> <sub>0</sub>	28.3 <sup>+0.3</sup> <sub>0</sub>	2-M6	—	—	—	—	—
28	28 <sup>+0.021</sup> <sub>0</sub>	7 <sup>+0.061</sup> <sub>+0.025</sub>	31.0 <sup>+0.3</sup> <sub>0</sub>	2-M6	28H	28 <sup>+0.021</sup> <sub>0</sub>	8 <sup>+0.036</sup> <sub>0</sub>	31.3 <sup>+0.3</sup> <sub>0</sub>	2-M6	28N	28 <sup>+0.028</sup> <sub>+0.007</sub>	8 <sup>+0.036</sup> <sub>0</sub>	31.3 <sup>+0.3</sup> <sub>0</sub>	2-M6
30	30 <sup>+0.021</sup> <sub>0</sub>	7 <sup>+0.061</sup> <sub>+0.025</sub>	33.0 <sup>+0.3</sup> <sub>0</sub>	2-M6	30H	30 <sup>+0.021</sup> <sub>0</sub>	8 <sup>+0.036</sup> <sub>0</sub>	33.3 <sup>+0.3</sup> <sub>0</sub>	2-M6	—	—	—	—	—
32	32 <sup>+0.025</sup> <sub>0</sub>	10 <sup>+0.061</sup> <sub>+0.025</sub>	35.5 <sup>+0.3</sup> <sub>0</sub>	2-M8	32H	32 <sup>+0.025</sup> <sub>0</sub>	10 <sup>+0.036</sup> <sub>0</sub>	35.3 <sup>+0.3</sup> <sub>0</sub>	2-M8	—	—	—	—	—
35	35 <sup>+0.025</sup> <sub>0</sub>	10 <sup>+0.061</sup> <sub>+0.025</sub>	38.5 <sup>+0.3</sup> <sub>0</sub>	2-M8	35H	35 <sup>+0.025</sup> <sub>0</sub>	10 <sup>+0.036</sup> <sub>0</sub>	38.3 <sup>+0.3</sup> <sub>0</sub>	2-M8	—	—	—	—	—
38	38 <sup>+0.025</sup> <sub>0</sub>	10 <sup>+0.061</sup> <sub>+0.025</sub>	41.5 <sup>+0.3</sup> <sub>0</sub>	2-M8	38H	38 <sup>+0.025</sup> <sub>0</sub>	10 <sup>+0.036</sup> <sub>0</sub>	41.3 <sup>+0.3</sup> <sub>0</sub>	2-M8	38N	38 <sup>+0.050</sup> <sub>+0.025</sub>	10 <sup>+0.036</sup> <sub>0</sub>	41.3 <sup>+0.3</sup> <sub>0</sub>	2-M8
40	40 <sup>+0.025</sup> <sub>0</sub>	10 <sup>+0.061</sup> <sub>+0.025</sub>	43.5 <sup>+0.3</sup> <sub>0</sub>	2-M8	40H	40 <sup>+0.025</sup> <sub>0</sub>	12 <sup>+0.043</sup> <sub>0</sub>	43.3 <sup>+0.3</sup> <sub>0</sub>	2-M8	—	—	—	—	—
42	42 <sup>+0.025</sup> <sub>0</sub>	12 <sup>+0.075</sup> <sub>+0.032</sub>	45.5 <sup>+0.3</sup> <sub>0</sub>	2-M8	42H	42 <sup>+0.025</sup> <sub>0</sub>	12 <sup>+0.043</sup> <sub>0</sub>	45.3 <sup>+0.3</sup> <sub>0</sub>	2-M8	42N	42 <sup>+0.050</sup> <sub>+0.025</sub>	12 <sup>+0.043</sup> <sub>0</sub>	45.3 <sup>+0.3</sup> <sub>0</sub>	2-M8
45	45 <sup>+0.025</sup> <sub>0</sub>	12 <sup>+0.075</sup> <sub>+0.032</sub>	48.5 <sup>+0.3</sup> <sub>0</sub>	2-M8	45H	45 <sup>+0.025</sup> <sub>0</sub>	14 <sup>+0.043</sup> <sub>0</sub>	48.8 <sup>+0.3</sup> <sub>0</sub>	2-M10	—	—	—	—	—
48	48 <sup>+0.025</sup> <sub>0</sub>	12 <sup>+0.075</sup> <sub>+0.032</sub>	51.5 <sup>+0.3</sup> <sub>0</sub>	2-M8	48H	48 <sup>+0.025</sup> <sub>0</sub>	14 <sup>+0.043</sup> <sub>0</sub>	51.8 <sup>+0.3</sup> <sub>0</sub>	2-M10	48N	48 <sup>+0.050</sup> <sub>+0.025</sub>	14 <sup>+0.043</sup> <sub>0</sub>	51.8 <sup>+0.3</sup> <sub>0</sub>	2-M10
50	50 <sup>+0.025</sup> <sub>0</sub>	12 <sup>+0.075</sup> <sub>+0.032</sub>	53.5 <sup>+0.3</sup> <sub>0</sub>	2-M8	50H	50 <sup>+0.025</sup> <sub>0</sub>	14 <sup>+0.043</sup> <sub>0</sub>	53.8 <sup>+0.3</sup> <sub>0</sub>	2-M10	—	—	—	—	—
55	55 <sup>+0.030</sup> <sub>0</sub>	15 <sup>+0.075</sup> <sub>+0.032</sub>	60.0 <sup>+0.3</sup> <sub>0</sub>	2-M10	55H	55 <sup>+0.030</sup> <sub>0</sub>	16 <sup>+0.043</sup> <sub>0</sub>	59.3 <sup>+0.3</sup> <sub>0</sub>	2-M10	55N	55 <sup>+0.060</sup> <sub>+0.030</sub>	16 <sup>+0.043</sup> <sub>0</sub>	59.3 <sup>+0.3</sup> <sub>0</sub>	2-M10
56	56 <sup>+0.030</sup> <sub>0</sub>	15 <sup>+0.075</sup> <sub>+0.032</sub>	61.0 <sup>+0.3</sup> <sub>0</sub>	2-M10	56H	56 <sup>+0.030</sup> <sub>0</sub>	16 <sup>+0.043</sup> <sub>0</sub>	60.3 <sup>+0.3</sup> <sub>0</sub>	2-M10	—	—	—	—	—
60	60 <sup>+0.030</sup> <sub>0</sub>	15 <sup>+0.075</sup> <sub>+0.032</sub>	65.0 <sup>+0.3</sup> <sub>0</sub>	2-M10	60H	60 <sup>+0.030</sup> <sub>0</sub>	18 <sup>+0.043</sup> <sub>0</sub>	64.4 <sup>+0.3</sup> <sub>0</sub>	2-M10	60N	60 <sup>+0.060</sup> <sub>+0.030</sub>	18 <sup>+0.043</sup> <sub>0</sub>	64.4 <sup>+0.3</sup> <sub>0</sub>	2-M10
65	65 <sup>+0.030</sup> <sub>0</sub>	18 <sup>+0.075</sup> <sub>+0.032</sub>	71.0 <sup>+0.3</sup> <sub>0</sub>	2-M10	65H	65 <sup>+0.030</sup> <sub>0</sub>	18 <sup>+0.043</sup> <sub>0</sub>	69.4 <sup>+0.3</sup> <sub>0</sub>	2-M10	65N	65 <sup>+0.060</sup> <sub>+0.030</sub>	18 <sup>+0.043</sup> <sub>0</sub>	69.4 <sup>+0.3</sup> <sub>0</sub>	2-M10
70	70 <sup>+0.030</sup> <sub>0</sub>	18 <sup>+0.075</sup> <sub>+0.032</sub>	76.0 <sup>+0.3</sup> <sub>0</sub>	2-M10	70H	70 <sup>+0.030</sup> <sub>0</sub>	20 <sup>+0.052</sup> <sub>0</sub>	74.9 <sup>+0.5</sup> <sub>0</sub>	2-M10	—	—	—	—	—
75	75 <sup>+0.030</sup> <sub>0</sub>	20 <sup>+0.092</sup> <sub>+0.040</sub>	81.0 <sup>+0.5</sup> <sub>0</sub>	2-M10	75H	75 <sup>+0.030</sup> <sub>0</sub>	20 <sup>+0.052</sup> <sub>0</sub>	79.9 <sup>+0.5</sup> <sub>0</sub>	2-M10	75N	75 <sup>+0.060</sup> <sub>+0.030</sub>	20 <sup>+0.052</sup> <sub>0</sub>	79.9 <sup>+0.5</sup> <sub>0</sub>	2-M10
80	80 <sup>+0.030</sup> <sub>0</sub>	20 <sup>+0.092</sup> <sub>+0.040</sub>	86.0 <sup>+0.5</sup> <sub>0</sub>	2-M10	80H	80 <sup>+0.030</sup> <sub>0</sub>	22 <sup>+0.052</sup> <sub>0</sub>	85.4 <sup>+0.5</sup> <sub>0</sub>	2-M12	—	—	—	—	—
85	85 <sup>+0.035</sup> <sub>0</sub>	24 <sup>+0.092</sup> <sub>+0.040</sub>	93.0 <sup>+0.5</sup> <sub>0</sub>	2-M12	85H	85 <sup>+0.035</sup> <sub>0</sub>	22 <sup>+0.052</sup> <sub>0</sub>	90.4 <sup>+0.5</sup> <sub>0</sub>	2-M12	85N	85 <sup>+0.071</sup> <sub>+0.036</sub>	22 <sup>+0.052</sup> <sub>0</sub>	90.4 <sup>+0.5</sup> <sub>0</sub>	2-M12
90	90 <sup>+0.035</sup> <sub>0</sub>	24 <sup>+0.092</sup> <sub>+0.040</sub>	98.0 <sup>+0.5</sup> <sub>0</sub>	2-M12	90H	90 <sup>+0.035</sup> <sub>0</sub>	25 <sup>+0.052</sup> <sub>0</sub>	95.4 <sup>+0.5</sup> <sub>0</sub>	2-M12	—	—	—	—	—
95	95 <sup>+0.035</sup> <sub>0</sub>	24 <sup>+0.092</sup> <sub>+0.040</sub>	103.0 <sup>+0.5</sup> <sub>0</sub>	2-M12	95H	95 <sup>+0.035</sup> <sub>0</sub>	25 <sup>+0.052</sup> <sub>0</sub>	100.4 <sup>+0.5</sup> <sub>0</sub>	2-M12	95N	95 <sup>+0.071</sup> <sub>+0.036</sub>	25 <sup>+0.052</sup> <sub>0</sub>	100.4 <sup>+0.5</sup> <sub>0</sub>	2-M12
100	100 <sup>+0.035</sup> <sub>0</sub>	28 <sup>+0.092</sup> <sub>+0.040</sub>	109.0 <sup>+0.5</sup> <sub>0</sub>	2-M12	100H	100 <sup>+0.035</sup> <sub>0</sub>	28 <sup>+0.052</sup> <sub>0</sub>	106.4 <sup>+0.5</sup> <sub>0</sub>	2-M12	—	—	—	—	—
115	115 <sup>+0.035</sup> <sub>0</sub>	32 <sup>+0.112</sup> <sub>+0.050</sub>	125.0 <sup>+0.5</sup> <sub>0</sub>	2-M12	115H	115 <sup>+0.035</sup> <sub>0</sub>	32 <sup>+0.062</sup> <sub>0</sub>	122.4 <sup>+0.5</sup> <sub>0</sub>	2-M12	—	—	—	—	—

### Distance from Set Screw Edge

Model	SFH-150	SFH-170	SFH-190	SFH-210	SFH-220	SFH-260
Distance from set screw edge [mm]	15	20	25	30	35	40

### Centering and Finishing when Drilling Bores in Flange Hubs

SFH models are delivered in component form. When processing bore diameters in pilot-bore products in particular, adjust the chuck so that runoff of each flange hub is no more than the precision of the figure at right, and then finish the inner diameter.

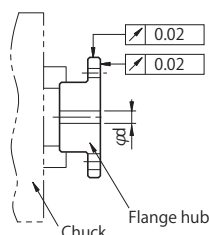

COUPLINGS

ETP BUSHINGS

ELECTROMAGNETIC CLUTCHES & BRAKES

SPEED CHANGERS & REDUCERS

INVERTERS

LINEAR SHAFT DRIVES

TORQUE LIMITERS

ROSTA

SERIES

Metal Couplings	Metal Disc Couplings
	SERVOFLEX
	High-rigidity Couplings
	SERVORIGID
Metal Slit Couplings	HELI-CAL
	Metal Coil Spring Couplings
	BAUMANNFLEX
Pin Bushing Couplings	PARAFLEX
	Link Couplings
Rubber and Plastic Couplings	SCHMIDT
	Dual Rubber Couplings
	STEPIFLEX
	Jaw Couplings
	MIKI PULLEY
	STARFLEX
	Jaw Couplings
	SPRFLEX
	Plastic Bellows Couplings
	BELLOWFLEX
Rubber and Plastic Couplings	
CENTAFLEX	

MODELS

SFC

SFS

SFF

SFM

SFH

Items Checked for Design Purposes

Special Items to Take Note of

You should note the following to prevent any problems.

- (1) Always be careful of parallel, angular, and axial misalignment.
- (2) Always tighten bolts with the specified torque.

Precautions for Handling

SFH models are delivered in component form. This mounts a flange hub on each shaft and couples both shafts by mounting the element (spacer) last, while centering. Also, the SFH S types can first mount an element on the flange hub, then center, and then complete the coupling before inserting it onto the shaft.

When using the assembly method that completes coupling first, take extra precautions when handling couplings. Subjecting assembled couplings to strong shocks may affect mounting accuracy and cause the parts to break during use.

- (1) Couplings are designed for use within an operating temperature range of -30°C to 120°C. Although the couplings are designed to be waterproof and oilproof, do not subject them to excessive amounts of water and oil as it may cause part deterioration.
- (2) Handle the element with care as it is made of a thin stainless steel metal disc, also making sure to be careful so as not to injure yourself.
- (3) For frictional coupling types, do not tighten up pressure bolts until after inserting the mounting shaft.

Centering

Parallel misalignment (ε)

Lock the dial gauge in place on one shaft and then measure the runout of the paired flange hub's outer periphery while rotating that shaft. Since couplings on which the elements (discs) are a set (SFH S types) do not allow parallel misalignment, get as close to zero as possible. For couplings that allow the entire length to be freely set (SFH G types), use the following formula to calculate allowable parallel misalignment.

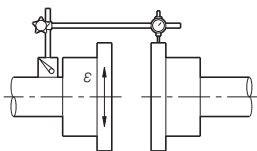

$$\epsilon = \tan \theta \times LG$$

ε : Allowable parallel misalignment  
θ : 1°

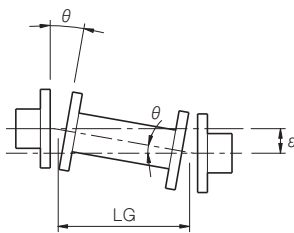

$$LG = LS + S$$

LS: Total length of spacer  
S: Dimension of gap between flange hub and spacer

Angular deflection (θ)

Lock the dial gauge in place on one shaft and then measure the runout of the end surface near the paired flange hub's outer periphery while rotating that shaft.

Adjust runout B so that θ ≤ 1° in the following formula.

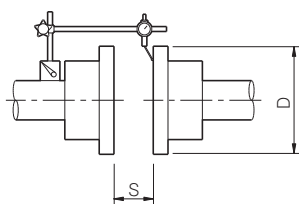

$$B = D \times \tan \theta$$

B: Runout  
D: Flange hub outer diameter  
θ : 1°

Axial displacement (S)

In addition, restrict the dimension between flange hub faces (S in the diagram) within the allowable error range for axial displacement with respect to a reference value. Note that the tolerance values were calculated based on the assumption that both the level of parallel misalignment and angular deflection are zero. Adjust to keep this value as low as possible.

\* On the SFH S, this is the dimension of the gap between two flange hubs. On the SFH G, dimension S is the gap between the flange hub and the spacer.

Mounting

This assembly method mounts a flange hub on each shaft of the SFH models and couples both shafts by mounting the element (spacer) last, while centering.

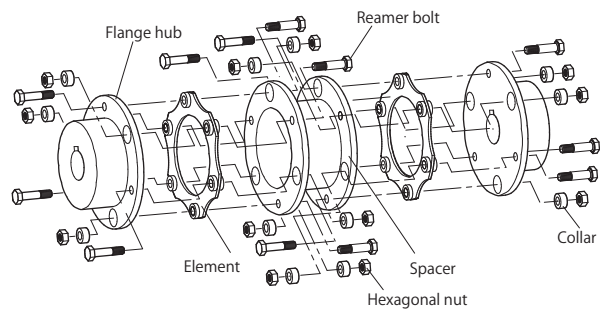

- (1) Remove any rust, dust, oil or the like from the inner diameter surfaces of the shaft and flange hubs. In particular, never allow oil or grease containing antifriction or other agent (molybdenum-, silicon-, or fluorine-based), which would dramatically affect the friction coefficient, to contact the surface.

For types that use frictional coupling, loosen the flange hub's pressure bolt and check that the sleeve can move freely.

- (2) Insert the flange hub onto the paired mounting shaft. Insert each shaft far enough into the coupling so that the paired mounting shaft touches the shaft along the entire length of the flange hub (LF dimension) as shown in the diagram below, and does not interfere with the elements, spacers or the other shaft.

SFH S types

SFH G types

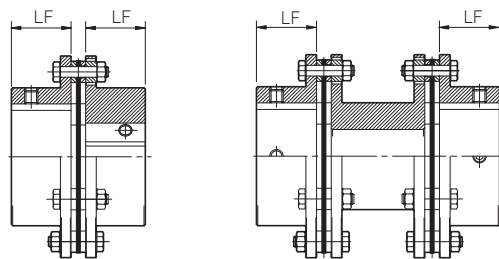

Coupling size	150	170	190	210	220	260
LF (key or set screw) [mm]	45	55	65	75	90	100
LF (frictional coupling) [mm]	65	65	70	73	-	-

- (3) Mount the other flange hub on the paired mounting shaft as described in steps (1) and (2).

- (4) With the flange hub inserted, center (parallel misalignment and angular deflection), and then adjust the distance between shafts.

- (5) For SFH S types, translate the flange hubs on the shaft, insert the element between the two flange hubs, and provisionally assemble with the reamer bolt, collar, and hexagonal nut. For SFH G types, insert reamer bolts from the flange side for both flanges, provisionally fasten the element and collar with a hexagonal nut, and then translate the flange hubs on the shaft, insert the spacer between the flange hubs, and provisionally assemble with the reamer bolt, collar and hexagonal nut.



# SFH Models

## Items Checked for Design Purposes

### I Mounting

- (6) Keep the width of the dimension between flange faces (S dimension in the diagram) within the allowable error range for axial misalignment with respect to the reference value. Note that the tolerance values were calculated based on the assumption that both the level of parallel misalignment and angular deflection are zero. Adjust to keep this value as low as possible.

#### ■ SFH S types

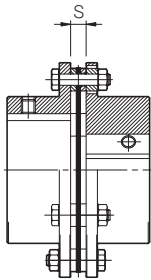

#### ■ SFH G types

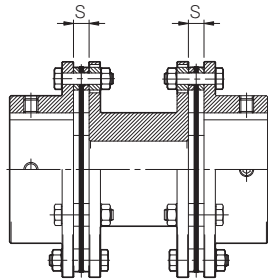

Coupling size	150	170	190	210	220	260
S [mm]	11	14	15	15	20	23

- (7) Check that the element is not deformed. If it is, it may be under an axial force or there may be insufficient lubrication between the collar, bolt, and disc, so adjust to bring it to normal. The situation may be improved by applying a small amount of machine oil to the bearing surface of the reamer bolt. However, never use any oil or grease containing antifriction or other agent (molybdenum-, silicon-, or fluorine-based) which would dramatically affect the friction coefficient.

- (8) Use a calibrated torque wrench to tighten all the reamer bolts to the appropriate tightening torques.

Coupling size	150	170	190	210	220	260
Reamer bolt size	M8	M10	M12	M16	M16	M20
Tightening torque [N·m]	34	68	118	300	300	570

- (9) When selecting a key system for the mounting on the shaft, lock the flange hub to the shaft with a set screw.

For frictional coupling types, tighten the pressure bolts evenly, a little at a time, on the diagonal, guided by the tightening procedure of the figure below.

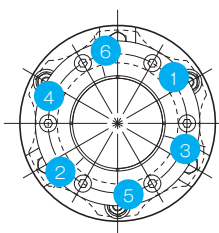

Type	Pressure bolt size	Tightening torque [N·m]
SFH-150S/G	M8	34
SFH-170S/G	M8	34
SFH-190S/G	M10	68
SFH-210S/G	M10	68

### I Removal

- (1) Check to confirm that there is no torque or axial load being applied to the coupling. There may be cases where a torque is applied to the coupling, particularly when the safety brake is being used. Make sure to verify that this is not occurring before removing parts.

- (2) Loosen all the pressure bolts placing pressure on the sleeve until the gap between bearing seat and sleeve is about 2 mm.

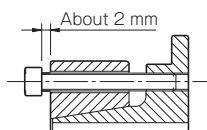

For a tapered coupling system that tightens pressure bolts from the axial direction, the sleeve will be self-locking, so the coupling between flange hub and shaft cannot be released simply by loosening the pressure bolt. (Note that in some cases, a coupling can be released by loosening a pressure bolt.) For that reason, when designing devices, a space must be installed for inserting a detachment screw.

If there is no space in the axial direction, consult Miki Pulley.

- (3) Pull out three of the pressure bolts loosened in step (2), insert them into detachment screw holes at three locations on the sleeve, and tighten them alternately, a little at a time. The link between the flange hub and shaft will be released.

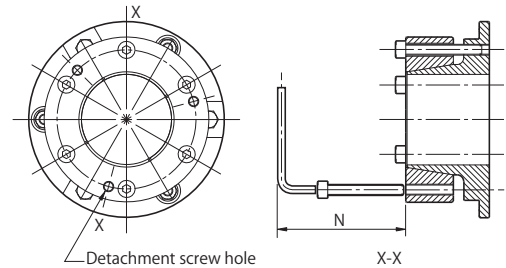

Coupling size	150	170	190	210
Nominal diameter of pressure bolt × Length	M8 × 60	M8 × 60	M10 × 65	M10 × 65
Recommended N dimension [mm]	108	108	121	121

### I Limit Rotation Speed

For SFH G long spacer types, the speeds at which the coupling can be used will vary with the length of spacer selected. Use the following table to confirm that the speed you will use is at or below the limit rotation speed.

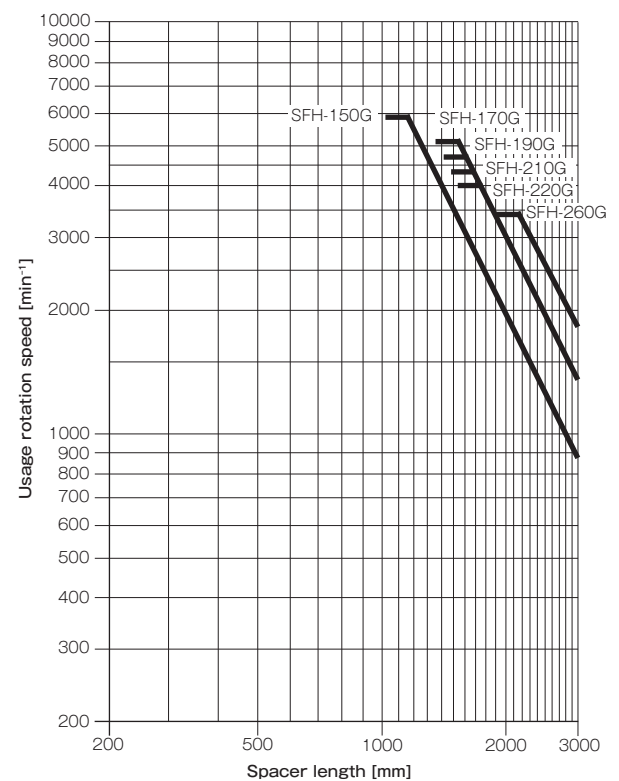

### I Points to Consider Regarding the Feed Screw System

#### ■ Servo motor oscillation

Gain adjustment on the servo motor may cause the servo motor to oscillate.

Oscillation in the servo motor during operation can cause problems particularly with the overall natural frequency and electrical control systems of the feed screw system.

In order for these issues to be resolved, the torsional stiffness for the coupling and feed screw section and the moment of inertia and other characteristics for the system overall will need to be adjusted and the torsional natural frequency for the mechanical system raised or the tuning function (filter function) for the electrical control system in the servo motor adjusted during the design stage.

Please contact Miki Pulley with any questions regarding servo motor oscillation.

## How to Find the Natural Frequency of a Feed Screw System

- Select a coupling based on the nominal and maximum torque of the servo motor.
- Find the overall natural frequency,  $N_f$ , from the torsional stiffness of the coupling and feed screw,  $\kappa$ , the moment of inertia of driving side,  $J_1$ , and the moment of inertia of driven side,  $J_2$ , for the feed screw system shown below.

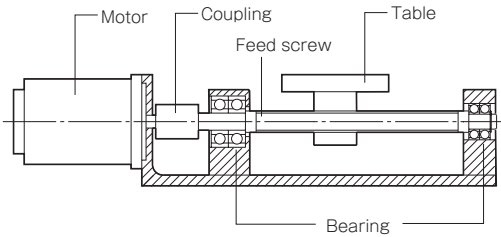

$$N_f = \frac{1}{2\pi} \sqrt{\kappa \left( \frac{1}{J_1} + \frac{1}{J_2} \right)}$$

- $N_f$ : Overall natural frequency of a feed screw system [Hz]  
 $\kappa$ : Torsional stiffness of the coupling and feed screw [N·m/rad]  
 $J_1$ : Moment of inertia of driving side [kg·m<sup>2</sup>]  
 $J_2$ : Moment of inertia of driven side [kg·m<sup>2</sup>]

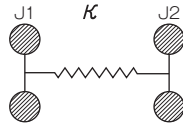

## Selection Procedures

- Find the torque,  $T_a$ , applied to the coupling using the output capacity,  $P$ , of the driver and the usage rotation speed,  $n$ .

$$T_a \text{ [N·m]} = 9550 \times \frac{P \text{ [kW]}}{n \text{ [min}^{-1}\text{]}}$$

- Determine the factor  $\kappa$  from the load properties, and find the corrected torque,  $T_d$ , applied to the coupling.

$$T_d = T_a \times K \text{ (Refer to the table below for values)}$$

Load properties	Constant	Vibrations: Small	Vibrations: Medium	Vibrations: Large
$K$	1.0	1.25	1.75	2.25

For servo motor drive, multiply the maximum torque,  $T_s$ , by the usage factor  $K = 1.2$  to  $1.5$ .

$$T_d = T_s \times (1.2 \text{ to } 1.5)$$

- Set the size so that the rated coupling torque,  $T_n$ , is higher than the corrected torque,  $T_d$ .

$$T_n \geq T_d$$

- The rated torque of the coupling may be limited by the bore diameter of the coupling. See the table showing the bore diameters that limit rated torque.
- Check that the mount shaft is no larger than the maximum bore diameter of the coupling.

Contact Miki Pulley for assistance with any device experiencing extreme periodic vibrations.

## Mounting Example

### SFH G

This is a combination of multiple standard bore-drilled couplings. Either Miki Pulley can do the processing, or you can drill pilot bores however you like.

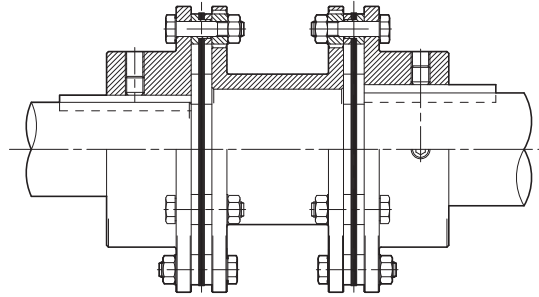

### SFH S

This example combines a frictional-coupling type flange and a standard bore-drilled flange hub.

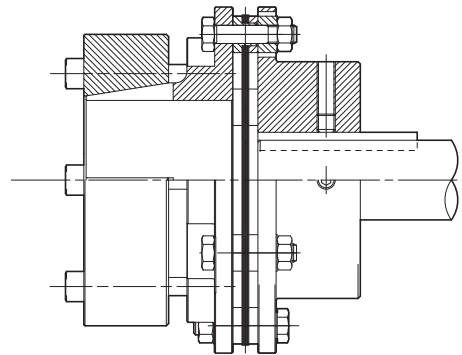

### SFH S special

This combines a flange hub processed for the tapered shaft of a servo motor with a flange hub processed for a Miki Pulley shaft lock PSL-G.

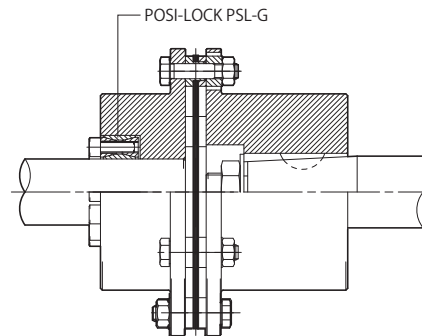

## COUPLINGS

ETP BUSHINGS

ELECTROMAGNETIC CLUTCHES & BRAKES

SPEED CHANGERS & REDUCERS

INVERTERS

LINEAR SHAFT DRIVES

TORQUE LIMITERS

ROSTA

## SERIES

Metal Couplings	Metal Disc Couplings	SERVOFLEX
	High-rigidity Couplings	SERVORIGID
	Metal Slit Couplings	HELI-CAL
	Metal Coil Spring Couplings	BAUMANNFLEX
	Pin Bushing Couplings	PARAFLEX
Link Couplings		SCHMIDT
	Dual Rubber Couplings	STEPFLEX
Rubber and Plastic Couplings	Jaw Couplings	MIKI PULLEY STARFLEX
	Jaw Couplings	SPRFLEX
	Plastic Bellows Couplings	BELLOWFLEX
	Rubber and Plastic Couplings	CENTAFLEX

## MODELS

SFC

SFS

SFF

SFM

SFH

## Torque Wrenches

### I SFC- □ SA2/DA2 (Clamping Bolt)

Nominal bolt diameter	Tightening torque [N·m]	Torque screwdriver (Preset)	Hexagon bit	Coupling size
M1.6	0.23 ~ 0.28	CN30LTDK	CB 1.5mm	002
M2	0.4 ~ 0.5	CN60LTDK	SB 1.5mm	005,010
M2.5	1.0 ~ 1.1	CN120LTDK	SB 2mm	010,020,025
M3	1.5 ~ 1.9	CN200LTDK	SB 2.5mm	030
M4	3.4 ~ 4.1	CN500LTDK	SB 3mm	035,040
M5	7.0 ~ 8.5	N10LTDK	SB 4mm	050
Nominal bolt diameter	Tightening torque [N·m]	Torque wrenches (Preset)	Hexagonal head	Coupling size
M6	14 ~ 15	N25LCK	25HCK 5mm	055,060
M8	27 ~ 30	N50LCK	50HCK 6mm	080,090,100

### I SFS- □ S/W/G (Pressure Bolt)

Nominal bolt diameter	Tightening torque [N·m]	Torque wrench (Single-function)	Wrench attachment	Coupling size
M5	8	N12SPCK × 8N · m	230SCK 8mm	05
M6	14	N25SPCK × 14N · m	230SCK 10mm	06,08,09,10
M8	34	N50SPCK × 34N · m	450SCK 13mm	12,14

### I SFS- □ S/W/G (Reamer Bolt)

Nominal bolt diameter	Tightening torque [N·m]	Torque wrench (Single-function)	Wrench attachment	Coupling size
M5	8	N12SPCK × 8N · m	25SCK 8mm	05
M6	14	N25SPCK × 14N · m	25SCK 10mm	06,08
M8	34	N50SPCK × 34N · m	50SCK 13mm	09,10
M10	68	N100SPCK × 68N · m	100SCK 17mm	12
M12	118	N200SPCK × 118N · m	200SCK 19mm	14

### I SFS- □ S/W/G-C (Reamer Bolt)

Nominal bolt diameter	Tightening torque [N·m]	Torque wrench (Single-function)	Wrench attachment	Coupling size
M5	6	N6SPCK × 6N · m	25SCK 8mm	05
M6	11	N12SPCK × 11N · m	25SCK 10mm	06,08
M8	26	N50SPCK × 26N · m	50SCK 13mm	09,10
M10	51	N100SPCK × 51N · m	100SCK 17mm	12
M12	90	N100SPCK × 90N · m	100SCK 19mm	14

### I SFF- □ SS/DS (Clamping Bolt)

Nominal bolt diameter	Tightening torque [N·m]	Torque screwdriver (Preset)	Hexagon bit	Coupling size
M4	3.4	CN500LTDK	SB 3mm	040
M5	7	N10LTDK	SB 4mm	050,060
Nominal bolt diameter	Tightening torque [N·m]	Torque wrenches (Preset)	Hexagonal head	Coupling size
M6	14	N25LCK	25HCK 5mm	060,070,080
M8	34	N50LCK	50HCK 6mm	080,090
Nominal bolt diameter	Tightening torque [N·m]	Torque wrench (Single-function)	Hexagonal head	Coupling size
M10	68	N100SPCK × 68N · m	100HCK 8mm	100,120

### I SFF- □ SS/DS (Pressure Bolt)

Nominal bolt diameter	Tightening torque [N·m]	Torque wrench (Single-function)	Wrench attachment	Coupling size
M6	10	N12SPCK × 10N · m	25SCK 10mm	070,080,090,100,120
M8	24	N50SPCK × 24N · m	50SCK 13mm	140

## SFM- □ SS (Clamping Bolt)

Nominal bolt diameter	Tightening torque [N·m]	Torque screwdriver (Preset)	Hexagon bit	Coupling size
M5	7	N10LTDK	SB 4mm	060
Nominal bolt diameter	Tightening torque [N·m]	Torque wrench (Preset)	Hexagonal head	Coupling size
M6	14	N25LCK	25HCK 5mm	060,070,080
M8	34	N50LCK	50HCK 6mm	080,090
Nominal bolt diameter	Tightening torque [N·m]	Torque wrench (Single-function)	Hexagonal head	Coupling size
M10	68	N100SPCK × 68N · m	100HCK 8mm	100,120

## SFM- □ SS (Pressure Bolt)

Nominal bolt diameter	Tightening torque [N·m]	Torque wrench (Single-function)	Wrench attachment	Coupling size
M6	10	N12SPCK × 10N · m	25SCK 10mm	070,080,090,100,120
M8	24	N50SPCK × 24N · m	50SCK 13mm	140

## SFH- □ S/G (Pressure Bolt)

Nominal bolt diameter	Tightening torque [N·m]	Torque wrench (Single-function)	Hexagonal head	Coupling size
M8	34	N50SPCK × 34N · m	50HCK 6mm	150,170
M10	68	N100SPCK × 68N · m	100HCK 8mm	190,210

## SFH- □ S/G (Reamer Bolt)

Nominal bolt diameter	Tightening torque [N·m]	Torque wrench (Single-function)	Wrench attachment	Coupling size
M8	34	N50SPCK × 34N · m	50SCK 13mm	150
M10	68	N100SPCK × 68N · m	100SCK 17mm	170
M12	118	N200SPCK × 118N · m	200SCK 19mm	190
M16	300	N4400SPCK × 300N · m	440SCK 24mm	210,220
Nominal bolt diameter	Tightening torque [N·m]	Torque wrenches (Preset)	Wrench attachment	Coupling size
M20	570	N700LCK	700SCK 30mm	260

## Torque Screwdriver (Preset)

■ N-LTDK

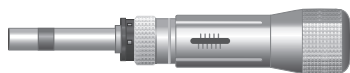

## Bit

■ SB



## Torque Wrenches (Preset)

■ N-LCK



## Hexagonal Head

■ HCK

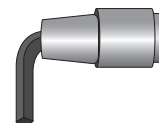

## Torque Wrench (Single-function)

■ N-SPCK

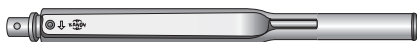

## Wrench Attachment

■ SCK



\* Torque screwdriver (wrench)/bit (head) models are those of Nakamura Mfg. Co., Ltd.

### COUPLINGS

ETP BUSHINGS

ELECTROMAGNETIC  
CLUTCHES & BRAKES

SPEED CHANGERS  
& REDUCERS

INVERTERS

LINEAR SHAFT DRIVES

TORQUE LIMITERS

ROSTA

### SERIES

Metal Couplings	Metal Disc Couplings SERVOFLEX
	High-rigidity Couplings SERVORIGID
	Metal Slit Couplings HELI-CAL
	Metal Coil Spring Couplings BAUMANNFLEX
Pin Bushing Couplings	PARAFLEX
	Link Couplings SCHMIDT
Rubber and Plastic Couplings	Dual Rubber Couplings STEPFLEX
	Jaw Couplings MIKI PULLEY STARFLEX
	Jaw Couplings SPRFLEX
	Plastic Bellows Couplings BELLOWFLEX
	Rubber and Plastic Couplings CENTAFLEX

### MODELS

SFC

SFS

SFF

SFM

SFH